

Panasonic

BUSINESS

AW-UE100W [White Model]
AW-UE100K [Black Model]
4K Integrated Camera



4K 60p/50p NDI®&SRT supported PTZ Camera with a compact body and a wide range of features

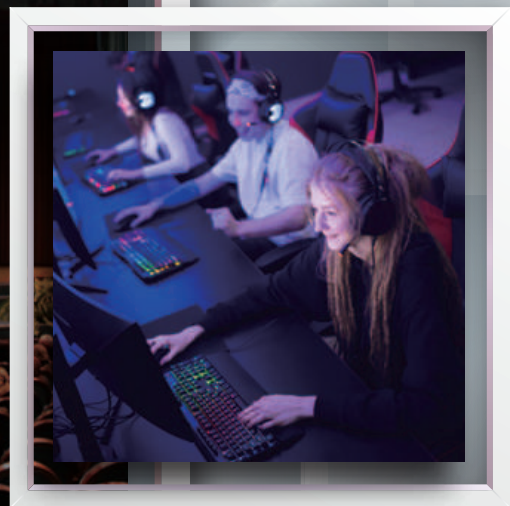

High-quality 4K PTZ Camera compatible with a variety of video transmission systems to support next-generation video production

This 4K Integrated Camera is compatible with various IP transmission protocols, including NDI®*1, SRT*2, and Freed*3, achieving flexible video production with high-quality 4K 60p/50p*4 video. 12G-SDI output is also supported in addition to 3G-SDI and HDMI, allowing the appropriate output to be selected for use in a wide range of situations, from live streaming of events to studio production.



High-Quality 4K 60p/50p*4 Shooting

3840 x 2160 4K output and 59.94p/50p*4 shooting achieve extremely smooth video, even in live sports and other environments containing rapid movement.

Output format	
4K (12G-SDI output/HDMI output)	2160/59.94p, 2160/50p, 2160/29.97p*5, 2160/25p*5, 2160/24p*5, 2160/23.98p*5
HD (3G-SDI output/HDMI output)	1080/59.94p, 1080/50p, 1080/29.97p*5, 1080/29.97PsF*6, 1080/25p*5, 1080/25PsF*6, 1080/23.98p*7, 1080/24p*5, 1080/23.98p*5, 1080/23.98PsF*6, 1080/59.94i, 1080/50i
	720/59.94p, 720/50p

1/2.5-type MOS sensor

The camera is equipped with a newly-developed 1/2.5-type 4K MOS sensor and achieves high-resolution video.

Shooting with 24x optical zoom and a 74.1° horizontal angle of view

In addition to 24x optical zoom, the inclusion of i.Zoom enables super resolution zooming of up to 36x in HD Mode and 28x in 4K mode while maintaining high resolution. The 1.4x and 2x digital extender zoom also allows distant subjects to be captured clearly, while the 74.1° horizontal angle of view enables a wide area to be shot from a limited installation space.

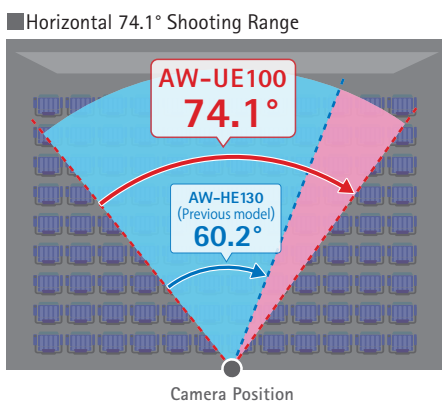

Newly-developed high-precision Direct Drive motor

The inclusion of a Direct Drive motor for the rotating section improves operability, responsiveness and quietness during pan/tilt operations.

operability

A wide range of speeds are supported, from slow movement of 0.08° per second to ultra-high speeds of 180° per second (Fast2 Mode).

responsiveness

Excellent responsiveness allows for accurate camera work, ensuring that the target area is captured.

quietness

A noise level of NC30 or less is ensured, enabling shooting in situations such as Concert hall and Studio where quietness is required.



Electronic Image Stabilization (EIS) for roll direction

Electronic Image Stabilization (EIS) for the roll direction has been added in addition to Optical Image Stabilization (OIS). Stable images with reduced blurring can be shot even in locations where special equipment such as a rail system or camera arms are used.



High image quality and low latency with high bandwidth NDI® support

High bandwidth NDI® and high efficiency low bandwidth NDI®|HX, which encode and transmit high-quality video in real time, are included. High bandwidth NDI® transmits 4K video at a maximum of 250 Mbps and full HD video at a maximum of 125 Mbps, enabling high-quality, low-latency live video transmission.

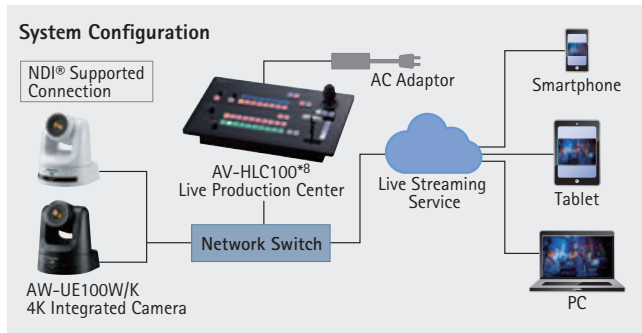

SRT*2 support for stable video transmission over public lines



SRT, a next-generation video transmission protocol with strong security suitable for unstable network environments, is supported.

Secure

Strong security is ensured by encrypting video data before transmission.

Reliable

The packet loss recovery function automatically detects and retransmits packets lost during transmission, ensuring smooth, stable video transmission.

Transport

The flexible and adaptable buffer management system enables stable video transmission even in network environments with unstable bit rates. Long-distance video transmission over public lines is supported.

Video transmission over public lines

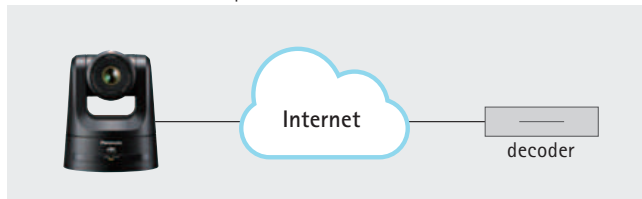

Direct Broadcast via RTMP/RTMPS*9

RTMP/RTMPS*9 is supported to enable direct upload of video to live-streaming services such as YouTube Live and Facebook Live. This means a live stream can be broadcast directly from the camera.

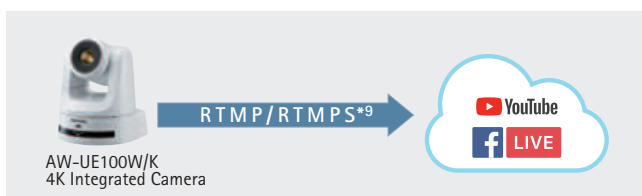

FreeD*3 Support for Construction of AR/VR*10 Systems

Integration with AR/VR systems is available via FreeD-compliant command output. Camera tracking information (pan/tilt/zoom/focus/iris) is output according to a synchronizing signal to facilitate configuration of virtual systems without an encoder.

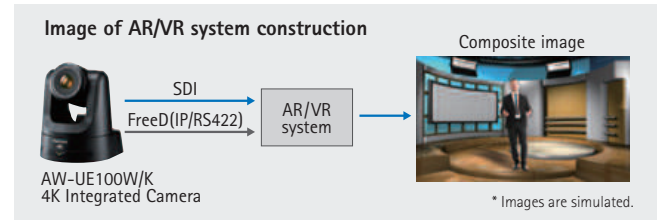

Cropping (+ Zoom) function

A cropped portion of the video can be created simultaneously during output of the full 4K video. Up to three crop areas can be specified, with easy operation using the AW-RP150GJ Remote Camera Controller and the web browser screen. The inclusion of cropping zoom also allows up to 5x zoom of cropped images.



* Images are simulated.

*1: NDI® is a new live video production workflow support protocol for IP use developed by NewTek in the United States. In this instance, NDI® is used to indicate high bandwidth NDI®. *2: SRT: Secure Reliable Transport. *3: FreeD: Widely used protocol for transmitting camera tracking information, mainly in virtual studio systems. *4: Actual output format is UHD (3840 x 2160) 59.94p/50p. *5: Native output. *6: Cannot be output from HDMI. *7: It denotes "1080/23.98p over 59.94i". *8: Only available during full HD operation. AV-HLC100 does not support 4K output. *9: RTMP: Real-Time Messaging Protocol. RTMPS: Real-Time Messaging Protocol Secure. *10: AR: Augmented Reality. VR: Virtual Reality. *11: Picture quality is lower with the cropping zoom.

Application Examples

Application 01: 4K Studio

Studio shooting of smooth, high-quality 4K 60p/50p*1 images

The AW-UE100W/K is capable of 4K 60p/50p*1 output for high-quality remote shooting in studio operations where high image quality is required. A large tally lamp has been equipped to make on-air cameras easily identifiable, even from far away.

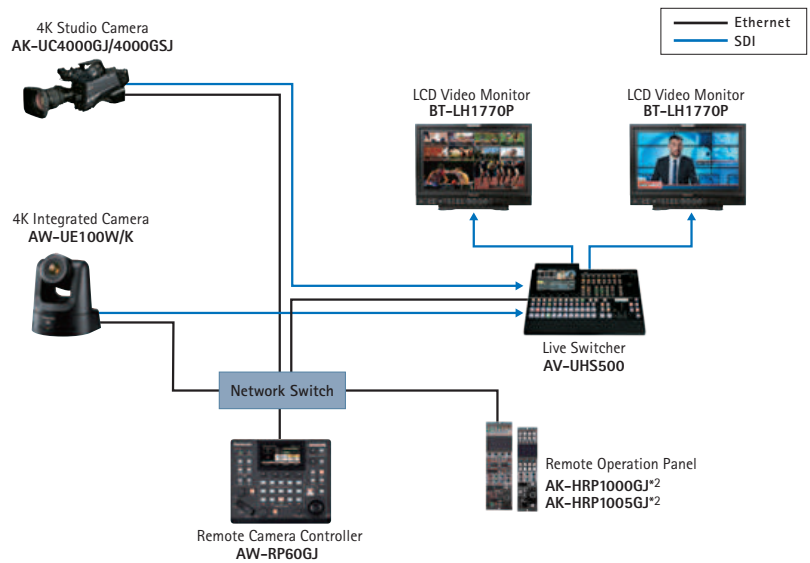

Application 02: Live Streaming

Select the optimal streaming workflow for each situation with RTMP/RTMPS and NDI®*3 support

When working with a single camera, video can be uploaded directly from AW-UE100W/K to live distribution services with RTMP/RTMPS. When multiple cameras are used, they can be connected to the AV-HLC100*2*4 Live Production Center with NDI®*3. Multiple AW-UE100W/K can be controlled from the AV-HLC100*2*4 for high-quality, low-latency live distribution.

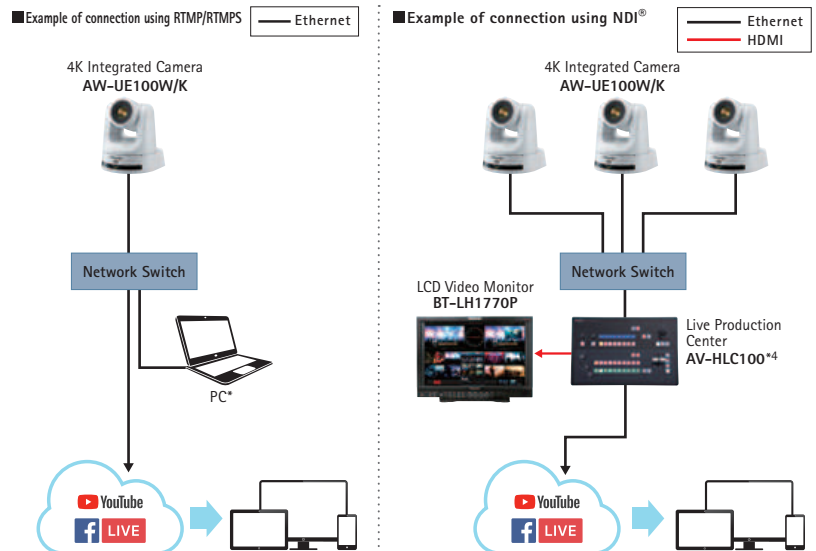

*A computer is required for server connection settings.

Application 03: Halls

High-magnification zoom and wide-angle shooting ensure targets are captured clearly in large venues

The large 1/2.5-type MOS sensor enables high-sensitivity shooting with little noise in halls and other dark locations. The optical 24x zoom further ensures that even far-away targets shot in large venues are captured clearly. 74.1° horizontal wide-angle shooting allows incredible flexibility in shooting location while still being able to capture the entire shot.

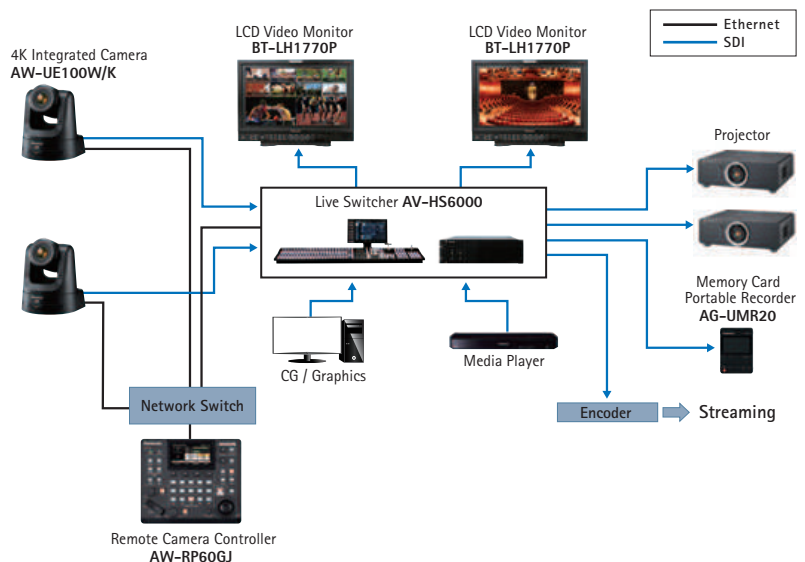

*1: Actual output format is UHD (3840 x 2160) 59.94p/50p.

*2: Use may require a software version update.

*3: NDI® is a new live video production workflow support protocol for IP use developed by NewTek in the United States. In this instance, NDI® is used to indicate high bandwidth NDI®.

*4: Only available during full HD operation. AV-HLC100 does not support 4K output.

Optional Products

PC Software for Remote Camera Support

Supporting Lecture Capture with Auto Tracking function

Auto Tracking Software Key

Stand-Alone and Web App Versions

AW-SF100*1

Server Version

AW-SF200*1

2 Additional Licenses (for AW-SF200)

AW-SF202*1

3 Additional Licenses (for AW-SF200)

AW-SF203*1

A 30-day Free Trial is Available

- High-performance auto tracking using highly-specialized facial recognition and deep learning technology allows the camera to follow lecturers in any direction.
- The AW-UE100W/K cropping function allows a single camera to crop and track up to three people.
- Operation with IP connection enables installation/control of cameras in remote classroom.
- AW-SF100 allows a single PTZ camera to be controlled on either a stand-alone or web application version. AW-SF200 operates on a server.
- The web application version enables camera control from a tablet, smartphone, desktop PC, etc.
- AW-SF200 enables simultaneous auto tracking and centralized control of multiple cameras.*2



AW-SF200 Main View

*1: Use may require a software version update.

*2: Up to four cameras per server can be controlled simultaneously.

* Depending on the shooting environment, the system may not be able to detect or track the target correctly. Please use this software in an environment where the adjustment work can be performed by the operator to deal with errors in detection and auto tracking. * There is a 30-day free trial available for the Auto Tracking Software. Please read carefully the precautions for this software and check if it works correctly in your operating environment before you purchase "Auto Tracking Software Activation Key". For further information, please see "Download / Software Download" on the Panasonic website <<https://pro-av.panasonic.net/>>.

• The face recognition function is based upon the face recognition software developed by PUX Corporation.

Control multiple PTZ Cameras from PC

PTZ Control Center Free software

- Video can be checked during centralized management of multiple cameras.
- Camera control enabled via GUI for image quality adjustment, pan, tilt, zoom, etc. Touch panel operations are supported.
- Clicking the preset button attached to thumbnails enables simple recall of presets.
- Pan, tilt, zoom and other operations can also be controlled using game controllers made by other companies.



Main screen

Software that converts PTZ camera on your network into Super Web cam

PTZ Virtual USB Driver Free software

- Remote cameras on the network can be used as USB cameras for simple execution of web meetings with high image quality.
- Camera controls such as image quality adjustment and pan/tilt/zoom can be operated from the GUI.
- Up to five cameras can be registered.
- Automatic detection of connected cameras and network settings enabled.

* For further information on the optional software, please see "Download / Software Download" on the Panasonic website <<https://pro-av.panasonic.net/>>.

Optional Products

As of August, 2020

Remote Camera Controller AW-RP150GJ*3

- A separate AC adaptor or PoE+ HUB is required for power supply.



Remote Camera Controller AW-RP60*3

- A separate AC adaptor or PoE HUB is required for power supply.



Live Switcher AV-UHS500



KAIROS
Incredible Productivity

IT/IP Platform
KAIROS



https://pro-av.panasonic.net/en/products/it_ip_platform/



Live Production Center AV-HLC100*3



Remote Operation Panel (ROP)

AK-HRP1000GJ*3*4
AK-HRP1005GJ*3*4*5
AK-HRP1015GJ*3*6

- A separate PoE HUB is required for power supply.



Wireless remote control AW-RM50G

(*AA*, *R6* or *LR6* battery x2 are not included.)



*3: Use may require a software version update.

*4: Support planned for the future.

*5: Limited Stock

*6: Scheduled for release in the fourth quarter of CY2020. Not available in some areas.

Specifications

<GENERAL>

Power Requirements:	12 V DC (10.8 V to 13.2 V) (Supplied AC adaptor) 42 V to 57 V DC (PoE++ power supply)
PoE++:	IEEE802.3bt standard: DC 42 V to 57 V (Camera Input) (Software authentication (LLDP) is supported)
Current Consumption:	3.0 A (Supplied AC adaptor) 1.0 A (PoE++ power supply)
Ambient Operating Temperature:	0 °C to 40 °C (32 °F to 104 °F)
Ambient Operating Humidity:	20 % to 90 % (no condensation)
Storage Temperature:	-20 °C to 50 °C (-4 °F to 122 °F)
Mass:	Approx. 2.2 kg (4.84 lb) (excluding cable cover, mount bracket) Approx. 2.3 kg (5.06 lb) (including cable cover, excluding mount bracket)
Dimensions (W x H x D):	169.2 mm x 204.6 mm x 170.6 mm (6-21/32 inches x 8-1/16 inches x 6-23/32 inches) (excluding protrusions, cable cover, mount bracket)
Finish:	AW-UE100WP/AW-UE100WPC/AW-UE100WE/AW-UE100WED: Pearl white AW-UE100KP/AW-UE100KPC/AW-UE100KE/AW-UE100KED: Black
Controller Supported:	AW-RP150GJ, AW-RP60GJ

<Camera Unit>

Imaging Sensors:	1/2.5-type 4K MOS x 1										
Lens:	Motorized Optical 24x zoom, F1.8 to F4.0 [f=4.12 mm (5/32 inches) to 98.9 mm (3-29/32 inches); 35 mm (1-3/8 inches) equivalent: 25.0 mm (31/32 inches) to 600.0 mm (23-5/8 inches)]										
Zoom:	<ul style="list-style-type: none"> Optical zoom : 24x i.Zoom: UHD 28x, FHD 36x Digital extender zoom: 1.4x, 2x 										
Conversion Lens:	Not supported										
Angle of View Range:	Horizontal angle of view: 74.1°(wide) to 3.3°(tele) Vertical angle of view: 46.0°(wide) to 1.9°(tele) Diagonal angle of view: 81.8°(wide) to 3.8°(tele)										
Optical Filter:	Through, 1/4, 1/16, 1/64, IR through (IR through is used as "Night mode")										
Focus:	Switching between auto and manual										
Focus Distance:	Entire zooming range: 1200 mm (3.9 ft) Wide end: 100 mm (0.33 ft)										
Color Separation Optical System:	1MOS										
Standard Sensitivity:	F4/2000 lx (When [Shooting Mode] is [Normal]) F5.6/2000 lx (When [Shooting Mode] is [High Sens.])										
Minimum Illumination:	3 lx (conditions: F1.8, 59.94p, 50 IRE, 42 dB, without accumulation)										
S/N:	60dB(typ) (When [Shooting Mode] is [Normal])										
Horizontal Resolution:	1500 TV lines Typ (Center area)										
Gain Selection:	Auto, 0 dB to 36 dB* • Super Gain function installed: 37 dB to 42 dB										
Frame Mix*2:	Auto, 0 dB, 6 dB, 12 dB, 18 dB, 24 dB										
Electronic Shutter Speed:	<table border="1"> <tr> <td>59.94p/59.94i</td> <td>1/60, 1/100, 1/120, 1/250, 1/500, 1/1000, 1/2000, 1/4000, 1/8000, 1/10000</td> </tr> <tr> <td>29.97p</td> <td>1/30, 1/60, 1/100, 1/120, 1/250, 1/500, 1/1000, 1/2000, 1/4000, 1/8000, 1/10000</td> </tr> <tr> <td>23.98p/24p</td> <td>1/24, 1/48, 1/60, 1/100, 1/120, 1/250, 1/500, 1/1000, 1/2000, 1/4000, 1/8000, 1/10000</td> </tr> <tr> <td>50p/50i</td> <td>1/60, 1/100, 1/120, 1/250, 1/500, 1/1000, 1/2000, 1/4000, 1/8000, 1/10000</td> </tr> <tr> <td>25p</td> <td>1/25, 1/50, 1/60, 1/100, 1/120, 1/250, 1/500, 1/1000, 1/2000, 1/4000, 1/8000, 1/10000</td> </tr> </table>	59.94p/59.94i	1/60, 1/100, 1/120, 1/250, 1/500, 1/1000, 1/2000, 1/4000, 1/8000, 1/10000	29.97p	1/30, 1/60, 1/100, 1/120, 1/250, 1/500, 1/1000, 1/2000, 1/4000, 1/8000, 1/10000	23.98p/24p	1/24, 1/48, 1/60, 1/100, 1/120, 1/250, 1/500, 1/1000, 1/2000, 1/4000, 1/8000, 1/10000	50p/50i	1/60, 1/100, 1/120, 1/250, 1/500, 1/1000, 1/2000, 1/4000, 1/8000, 1/10000	25p	1/25, 1/50, 1/60, 1/100, 1/120, 1/250, 1/500, 1/1000, 1/2000, 1/4000, 1/8000, 1/10000
59.94p/59.94i	1/60, 1/100, 1/120, 1/250, 1/500, 1/1000, 1/2000, 1/4000, 1/8000, 1/10000										
29.97p	1/30, 1/60, 1/100, 1/120, 1/250, 1/500, 1/1000, 1/2000, 1/4000, 1/8000, 1/10000										
23.98p/24p	1/24, 1/48, 1/60, 1/100, 1/120, 1/250, 1/500, 1/1000, 1/2000, 1/4000, 1/8000, 1/10000										
50p/50i	1/60, 1/100, 1/120, 1/250, 1/500, 1/1000, 1/2000, 1/4000, 1/8000, 1/10000										
25p	1/25, 1/50, 1/60, 1/100, 1/120, 1/250, 1/500, 1/1000, 1/2000, 1/4000, 1/8000, 1/10000										
Synchro Scan:	<table border="1"> <tr> <td>59.94p/59.94i</td> <td>60.00 Hz to 7200 Hz</td> </tr> <tr> <td>29.97p</td> <td>30.00 Hz to 7200 Hz</td> </tr> <tr> <td>23.98p/24p</td> <td>24.00 Hz to 7200 Hz</td> </tr> <tr> <td>50p/50i</td> <td>50.00 Hz to 7200 Hz</td> </tr> <tr> <td>25p</td> <td>25.00 Hz to 7200 Hz</td> </tr> </table>	59.94p/59.94i	60.00 Hz to 7200 Hz	29.97p	30.00 Hz to 7200 Hz	23.98p/24p	24.00 Hz to 7200 Hz	50p/50i	50.00 Hz to 7200 Hz	25p	25.00 Hz to 7200 Hz
59.94p/59.94i	60.00 Hz to 7200 Hz										
29.97p	30.00 Hz to 7200 Hz										
23.98p/24p	24.00 Hz to 7200 Hz										
50p/50i	50.00 Hz to 7200 Hz										
25p	25.00 Hz to 7200 Hz										
Gamma:	HD/FILMLIKE1/FILMLIKE2/FILMLIKE3										
White Balance:	ATW, 3200K, 5600K AWB: AWB-A/AWB-B VAR (selectable between 2000K and 15000K by designating a value)										
Chroma Amount Variability:	OFF, -99 % to 99 %										
Scene File:	Scene1, Scene2, Scene3, Scene4										
Output Format:	<table border="1"> <tr> <td>SDI Output 4K</td> <td>2160/59.94p, 2160/50p, 2160/29.97p*, 2160/25p*, 2160/24p*, 2160/23.98p*</td> </tr> <tr> <td>SDI Output HD</td> <td>1080/59.94p, 1080/50p, 1080/29.97p*, 1080/29.97PsF, 1080/25p*, 1080/25PsF, 1080/23.98p*, 1080/24p*, 1080/23.98p*, 1080/23.98PsF, 1080/59.94i, 1080/50i, 720/59.94p, 720/50p</td> </tr> </table>	SDI Output 4K	2160/59.94p, 2160/50p, 2160/29.97p*, 2160/25p*, 2160/24p*, 2160/23.98p*	SDI Output HD	1080/59.94p, 1080/50p, 1080/29.97p*, 1080/29.97PsF, 1080/25p*, 1080/25PsF, 1080/23.98p*, 1080/24p*, 1080/23.98p*, 1080/23.98PsF, 1080/59.94i, 1080/50i, 720/59.94p, 720/50p						
SDI Output 4K	2160/59.94p, 2160/50p, 2160/29.97p*, 2160/25p*, 2160/24p*, 2160/23.98p*										
SDI Output HD	1080/59.94p, 1080/50p, 1080/29.97p*, 1080/29.97PsF, 1080/25p*, 1080/25PsF, 1080/23.98p*, 1080/24p*, 1080/23.98p*, 1080/23.98PsF, 1080/59.94i, 1080/50i, 720/59.94p, 720/50p										

Output Format:	HDMI Output 2160/59.94p, 2160/50p, 2160/29.97p*, 2160/25p*, 2160/24p*, 2160/23.98p*
	HDMI Output HD 1080/59.94p, 1080/50p, 1080/29.97p*, 1080/25p*, 1080/23.98p*, 1080/24p*, 1080/23.98p*, 1080/59.94i, 1080/50i, 720/59.94p, 720/50p

<Synchronization System>

Internal/External synchronization (BBS/Tri-level sync)

<INPUT>

Input Connector:	DC IN 12 V
G/L IN	BBS (Black Burst Sync), tri-level sync supported 75 Ω terminal (BNCx1)
AUDIO IN	<p>MIC/LINE input Compatible (SDI/HDMI/IP) AAC compatible (compatible with IP only) ø 3.5 mm stereo mini jack Input impedance: Approx. 10 kΩ (unbalanced)</p> <ul style="list-style-type: none"> During MIC input Input level: -40 dBV (0 dB=1 V/Pa, 1 kHz) Plug-in power compatible, supply voltage: 2.5 V ± 0.5 V During LINE input Input level: -10 dBV Input volume variable range: -36 dB to 12 dB (3 dB step) Embedded audio output level: -12 dBFS Sampling frequency: 48 kHz Quantization bit rate: 24bit (SDI, HDMI), 16bit (IP)

<OUTPUT>

Video Output:	HDMI HDMI 2.0 connector 4:2:2/10bit • HDCP is not supported. • Viera Link is not supported.
	12G-SDI OUT SMPTE 2082-1/SMPTE292 standard/75 Ω (BNC x 1)
	3G-SDI OUT SMPTE292/75 Ω (BNC x 1) • Level-A/Level-B supported

<INPUT/OUTPUT>

Input / Output Connector:	LAN RJ-45 LAN terminal for IP control and video transmission PoE++ power terminal (IEEE802.3bt compliant)
	RS-422 CONTROL IN RS-422A (RJ-45)

<Pan-tilt Head Unit>

Camera/Pan-tilt Head Control:	IP connecting cable • When connecting through a PoE++ hub LAN cable*5 (category 5e or above, straight cable), max. 100 m (328 ft) • When a PoE++ hub is not used LAN cable*5 (category 5e or above, straight cable), max. 100 m (328 ft)
	AW protocol connecting cable LAN cable*5 (category 5e or above, straight cable), max. 1000 m (3280 ft)
Installation Method:	Stand-alone (Desktop) or suspended (Hanging)*8
Pan/tilt Operation Speed:	Speed range: 0.08°/s to 60°/s (Normal mode) • 3 speed modes installed Normal: 60°/s, Fast1: 90°/s*, Fast2: 180°/s*
Panning Range:	±175°
Tilting range:	-30° to 210°**
Quietness:	NC30 or less

<Supported operating systems and web browsers>*9

Supported operating systems and web browsers:	Windows Microsoft® Windows® 10 Windows® Internet Explorer® 11 (64bit/32bit) Microsoft Edge Google Chrome
	Mac macOS 10.13/Safari 13 macOS 10.14/Safari 13 macOS 10.15/Safari 13 macOS 10.15/Google Chrome
	iPhone / iPad iOS Safari iPadOS
	Android Android OS Google Chrome

<IP Streaming>

Image Streaming Mode:	JPEG(MJPEG), H.264, H.265, NDI®/HX, High Bandwidth NDI®
Image Resolution:	3840x2160, 1920x1080, 1280x720, 640x360, 320x180
Image Transmission setting (JPEG):	Frame Rate: Maximum 30 fps Image quality (Fine / Normal)

Image Transmission Setting (H.264):	<ul style="list-style-type: none"> Transmission Type: Unicast port (AUTO) Unicast port (MANUAL) Multicast port Transmission Priority Constant bit rate Frame rate Best effort Frame Rate [60Hz] 5fps/15fps/30fps/60fps (UHD: 30fps, 60fps) [50Hz] 5fps/12.5fps/25fps/50fps (UHD: 25fps, 50fps) Max Bit Rate 512kbps/768kbps/1024kbps/1536kbps/2048kbps/3072kbps/4096kbps/ 6144kbps/8192kbps/10240kbps/12288kbps/14336kbps/16384kbps/ 20480kbps/24576kbps/32768kbps/40960kbps/51200kbps/76800kbps
	<ul style="list-style-type: none"> Transmission Type: Unicast port (AUTO) Unicast port (MANUAL) Multicast port

Image Transmission Setting (H.265):	<ul style="list-style-type: none"> Transmission Type: Unicast port (AUTO) Unicast port (MANUAL) Multicast port Frame Rate [60Hz]30fps [50Hz]25fps Max Bit Rate 8192kbps/12288kbps/25600kbps/51200kbps/76800kbps
	<ul style="list-style-type: none"> Transmission Type: Unicast port (AUTO) Unicast port (MANUAL) Multicast port

Audio Compression Type:	AAC-LC, 48 kHz / 16 bit / 2ch
Supported Protocol:	<ul style="list-style-type: none"> IPv6: TCP/IP, UDP/IP, HTTP, HTTPS, DNS, NTP, DHCPv6, RTP, MLD, ICMP, ARP, RTMP, SRT IPv4: TCP/IP, UDP/IP, HTTP, HTTPS, RTSP, RTP, RTP/RTCP, DHCP, DNS, DDNS, NTP, IGMP, ICMP, ARP, RTMP, RTSP, SRT

<Other Function>

NDI® support:	NDI® HX : Included as standard High Bandwidth NDI®: Included as standard
Tally LED display color:	red / green

*1: 1 dB steps. *2: This cannot be configured when the format is 2160/29.97p, 2160/23.98p, 2160/24p, 2160/25p, 1080/29.97p, 1080/23.98p(59.94i), 1080/29.97PsF, 1080/23.98PsF, 1080/25p, 1080/25PsF. *3: Native output. *4: OVER 59.94i output (your monitor may recognize the signal as 59.94i). *5: Use of an STP (shielded twisted pair) cable is recommended. *6: To ensure safety, the unit must be secured using the mount bracket supplied. *7: Note that the operating noise may be loud in high speed. If the operating noise is disturbing, use the Normal mode. *8: Depending on the pan or tilt position, the camera may be reflected in the image. *9: Supported OS indicated are for browsers current as of August 2020. See "Service and Support / PASS" on the Panasonic website (<https://pro-av.panasonic.net/en/>) for the latest information on browser support. *10: It denotes "1080/23.98p over 59.94p"

Dimensions

As of August, 2020

Unit: mm (inches)

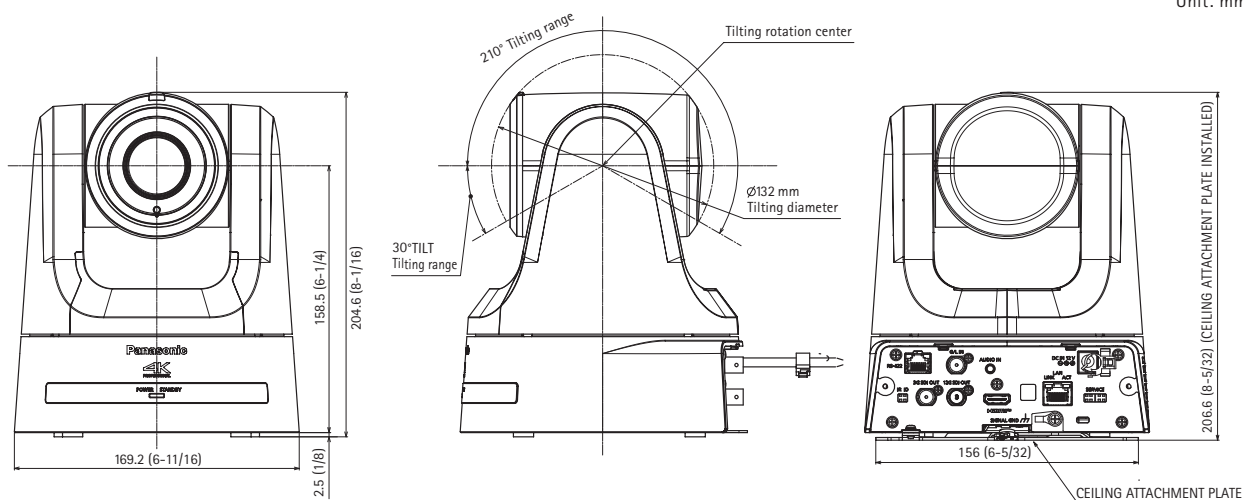

Rear View

Bottom View

Unit: mm (inches)

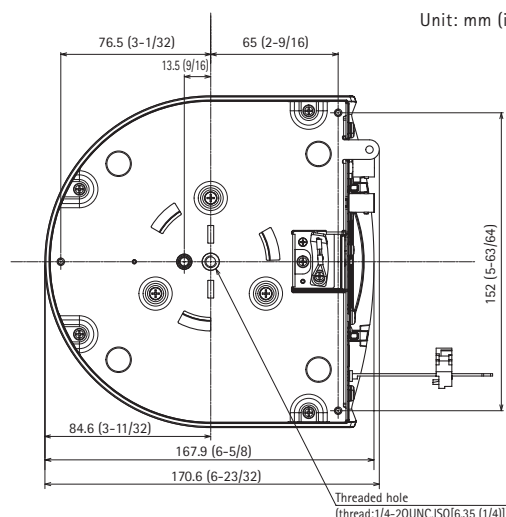

Compatible Third-Party Equipment

NewTek, Inc.

TriCaster TC1 2RU
TC1
 Operation-verified in June, 2020



TriCaster Mini 4K
TCM4KUHD
 Operation-verified in June, 2020



Explorer Inc.

SRT compatible
 H.265/HEVC 4K/2K decoder
EHU-3410D
 Operation-verified in June, 2020



Haivision

SRT Set Top Box
Haivision Play Set-Top Box 4000
 Operation-verified in June, 2020



GeoVision

PoE Adapter
GV-PA901
 Operation-verified in Mar. 2017



PoE++

NETGEAR, Inc.

NETGEAR 10-PORT GIGABIT
 ETHERNET ULTRAGO POE++
 SMART MANAGED PRO
 DESKTOP SWITCH

GS110TUP*1

Operation-verified in Mar. 2020



PoE++

NETGEAR 10-PORT GIGABIT
 ULTRAGO POE++ SMART
 MANAGED PRO
 RACKMOUNT SWITCH

GS710TUP*1

Operation-verified in Mar. 2020



PoE++

Allied Telesis

Gigabit Layer3 PoE++ Switch
AT-x320-10GH*1
 Operation-verified in Mar. 2020



PoE++

•Power supply not included.
 AT-PWR300 is required.

PLANET Technology Corp.

Layer 3 8-Port 10/100/1000T 802.3bt
 PoE + 2-Port 10/100/1000T + 2-Port
 10G SFP+ Managed Switch

GS-5220-8UP2T2X

Operation-verified in Oct. 2018



PoE++

*1: LLDP authentication is planned for future support.

Third-Party Inquiries

- <NewTek, Inc.> <https://www.ndi.tv/> MAIL: ndi@newtek.com TEL: +1 210-370-8000
- <Explorer Inc.> MAIL: sales@explorer-inc.co.jp TEL: +81(138)47-7604
- <Haivision> <https://www.haivision.com/contact/>
- <GeoVision Inc.> MAIL: sales@geovision.com.tw TEL: +886-2-8797-8376
- <NETGEAR, Inc.> <http://www.netgear.com/home/contact-us/>
- <Allied Telesis> (North America) <http://alliedtelesis.com/contact>
 (Asia/Pacific) customer_info@alliedtelesis.com
 (EMEA) Customer_info@alliedtelesis.com
 (Central South America) Customer_info@alliedtelesis.com
- <PLANET Technology Corp.> <https://www.planet.com.tw/en> MAIL: sales@planet.com.tw

* Microsoft®, Windows®, Windows® XP, Windows® 7, Windows® 8, Windows® 8.1, Windows® 10 and Internet Explorer® are either registered trademarks or trademarks of Microsoft Corporation in the United States and other countries.

* Apple, Mac, OS X, iPhone, iPod Touch, iPad, and Safari are registered trademarks of Apple Inc., in the United States and other countries.

* Android™ is a trademark of Google Inc.

* "YouTube" and the "YouTube logo" are registered trademarks of Google Inc.

* "Facebook" is a registered trademark of Facebook, Inc.

* NDI® and NDI®|HX are registered trademarks of NewTek, Inc. in the United States.

* Specifications are subject to change without notice.

Panasonic®

Panasonic Corporation
 Connected Solutions Company

2-15 Matsuba-cho, Kadoma, Osaka 571-8503 Japan



For more information, please visit Panasonic web site
<https://pro-av.panasonic.net/en/qr/>



Factories of AVC Networks Company have received ISO14001:2004-the Environmental Management System certification. (Except for 3rd party's peripherals.)



Broadcast and
 Professional
 AV Website



Contact Information



Facebook



Mobile App