

USO RESTRITTO

MediorNet

User Manual



USO RESTRITTO



© 2014 Riedel Communications GmbH & Co KG. ALL RIGHTS RESERVED.
UNDER THE COPYRIGHT LAWS, THIS MANUAL MAY NOT BE COPIED, IN WHOLE OR IN PART, WITHOUT THE WRITTEN CONSENT OF RIEDEL. EVERY EFFORT HAS BEEN MADE TO ENSURE THAT THE INFORMATION IN THIS MANUAL IS ACCURATE. RIEDEL IS NOT RESPONSIBLE FOR PRINTING OR CLERICAL ERRORS. ALL TRADEMARKS ARE THE PROPERTY OF THEIR RESPECTIVE OWNERS.

CONTENT

1	Preface	5
1.1	Information.....	6
1.2	Package Version.....	9
1.3	About MediorNet.....	10
2	MediorNet-Modular	12
2.1	MN-PSU	14
2.2	MN-FAN	15
2.3	MN-XSS	16
2.4	MN-LNKx.....	20
2.4.1	<i>MN-LNK2</i>	20
2.4.2	<i>MN-LNK4</i>	21
2.4.3	<i>MN-LNK8-CWDM(80)</i>	22
2.4.4	<i>MN-LNK8-CWDM(80)-H</i>	23
2.4.5	<i>MN-LNK10-CWDM</i>	24
2.4.6	<i>MN-LNK18-CWDM</i>	25
2.5	Media Cards.....	26
2.5.1	<i>MN-HD4I</i>	26
2.5.2	<i>MN-HD4O</i>	27
2.5.3	<i>MN-HDO-4IO</i>	28
2.5.4	<i>MN-HD6</i>	29
2.5.5	<i>MN-HDP6</i>	30
2.5.6	<i>MN-MA2EO</i>	31
2.5.7	<i>MN-RN300</i>	32
2.5.8	<i>MN-MBP</i>	35
2.5.9	<i>MN-MIO-E</i>	42
2.5.10	<i>MN-MIO-T</i>	44
2.5.11	<i>MN-ETH6</i>	45
2.5.12	<i>MN-GV2</i>	46
2.5.13	<i>MN-ST-AL2</i>	47
2.6	MN-Modular Card Information.....	48
2.7	MN-Modular Status LEDs.....	49
3	MediorNet-Compact	52
3.1	MN-Compact Ports.....	58
3.2	MN-Compact-Fiber-Options.....	64
3.3	MN-Compact-Option-Cards.....	66
3.3.1	<i>MN-C-OPT-GV2</i>	66
3.3.2	<i>MN-C-OPT-SDI</i>	67
3.3.3	<i>MN-C-OPT-HDMI</i>	69
3.4	MN-Compact Status LEDs.....	71
4	General Information	74
4.1	Transport Latencies.....	74
4.2	Supported Formats.....	75
4.3	Wiring	77
4.4	MADI Format.....	79
5	MediorWorks	80
5.1	What is required?.....	80
5.2	Start of the MediorNet frames.....	81
5.3	Download of MediorWorks.....	81
5.4	Start of MediorWorks.....	83
5.5	MediorWorks Structure.....	84
5.6	How to.....	88
5.6.1	<i>Renaming</i>	88
5.6.2	<i>Configuration of Audio- / Video-formats</i>	89
5.6.3	<i>Setup a Connection</i>	93
5.6.4	<i>Save a Configuration</i>	97

USO RESTRITO

5.7	Features in Detail.....	98
5.7.1	Supported Cards.....	98
5.7.2	Icons	99
5.7.3	OSD On-Screen Display.....	102
5.7.4	Construction / Production - Mode.....	103
5.7.5	Reroute Priority.....	104
5.7.6	RockNet View.....	105
5.7.7	CONFIGURATION - window.....	113
5.7.8	STATUS - window.....	188
5.7.9	CONNECTION OVERVIEW - window.....	250
5.7.10	Synchronization.....	251
5.7.11	Timecode.....	252
5.7.12	Bandwidth.....	253
5.7.13	Firmware-Update.....	255
5.7.14	Reset Frame to factory default.....	260
5.8	Menus of MediorWorks Software.....	261
5.8.1	File	261
5.8.2	Workspace.....	263
5.8.3	System.....	264
5.8.4	Views	276
5.8.5	3rd Party Interfaces.....	295
5.8.6	Help	302
5.9	Menus of MediorUpdate Software.....	303
5.9.1	File	304
5.9.2	System.....	304
5.9.3	Options.....	304
6	Appendix	305
6.1	Technical Specifications.....	305
6.2	Glossary.....	306
6.3	Service	307

USO RESTRITTO

1 Preface

Thank you for choosing a Riedel product.

The purpose of this document is to introduce and explain the MediorNet System and the MediorWorks Software. This manual is divided in different parts. These are including a general description of the MediorNet system, features and typical applications, followed by declarations of the single functions.

For further information about MediorNet, please contact your local distributor or the Riedel headquarters in Wuppertal.

NOTICE

This manual, as well as the software and any examples contained herein are provided "as is" and are subject to change without notice. The content of this manual is for informational purpose only and should not be construed as a commitment by Riedel Communications GmbH & Co. KG & Co. KG or its suppliers. Riedel Communications GmbH & Co. KG & Co. KG gives no warranty of any kind with regard to this manual or the software, including, but not limited to, the implied warranties of merchantability and fitness for a particular purpose. Riedel Communications GmbH & Co. KG & Co. KG shall not be liable for any errors, inaccuracies or for incidental or consequential damages in connection with the furnishing, performance or use of this manual, the software or the examples herein. Riedel Communications GmbH & Co. KG & Co. KG reserves all patent, proprietary design, title and intellectual property rights contained herein, including, but not limited to, any images, text, photographs incorporated into the manual or software.

All title and intellectual property rights in and to the content that is accessed through use of the products is the property of the respective owner and may be protected by applicable copyright or other intellectual property laws and treaties.

MediorNet User Manual 2.00.0

© März 2014 Copyright Riedel Communications GmbH & Co. KG. ALL RIGHTS RESERVED.

Microsoft® and Windows® are registered trademarks of Microsoft Corporation.

Adobe® is a registered trademark of Adobe Systems Incorporated.

Apple and Mac are registered trademarks of Apple Computer, Inc.

All other trademarks are the property of their respective owner.





1.1 Information

▼ Symbols

The following tables are used to indicate hazards and provide cautionary information in relation to the handling and use of the equipment.

Danger	
	Indicates an imminently hazardous situation which, if not avoided, will result in death or serious injury.
	The highlighted line indicates the activity to prevent the danger.

Warning	
	Indicates a potentially hazardous situation which, if not avoided, could result in death or serious injury.
	The highlighted line indicates the activity to prevent the danger.

Caution	
	Indicates a potentially hazardous situation which, if not avoided, may result in minor or moderate injury. It may also be used to alert against unsafe practices.
	The highlighted line indicates the activity to prevent the danger.

	This text is for generally information. It indicates the activity for ease of work or for better understanding.
---	---

▼ Service

- All service has to be undertaken ONLY by qualified Riedel service personnel.
- There are no user serviceable parts inside the Frame.
- Do not plug in, turn in or attempt to operate an obviously damaged unit.
- Never attempt to modify the equipment components for any reason.

Caution	
	All adjustments have been done at the factory before the shipment of the devices. No maintenance is required and no user serviceable parts are inside the module.

USO RESTRITTO

▼ Voltage

- Ensure that the supply voltage available at the installation site meets the voltage range of the equipment.
- The power cable should only be connected to a correctly grounded source.
- Do not use any adapters.
- Never bypass a ground contact.
- Only use the power cables provided with the equipment.
- The power cord must be rated for the product and for the voltage and current marked on the product's label
- When you remove a power cable never pull on the cable itself but on the connector. A damaged cable could lead to shocks or burns.
- Only use extension cords that are 3 poled and grounded. The power cables are equipped with 3 pole connectors in order to minimize the risk of an electric shock.

Danger	
	<p>Non-observance can lead to electrical shock. Do not open the chassis.</p>

▼ Environment

- Never place the Frame in an area of high dust particles or humidity.
- Operating temperature of the system: -5°C - +40°C.
- Never place containers with any liquids on top of the Frame.
- If the equipment has been exposed to a cold environment and transferred to a warm environment, condensation may form inside the housing. Wait at least 6 hours before applying any power to the equipment.

▼ Ventilation

Do not place the Frame next to a heat source, f.i. a radiator. Ventilation openings on the left and right side of the Frame must never be blocked. Please also note that, in case of a rack installation.

▼ CE Declaration of Conformity

	<p>The MediorNet devices conform to the EU guideline EMC 2004 / 108 / EG Low - Voltage 2006 / 95 / EC as attested by the CE mark.</p>
---	--

▼ **Laser Safety**

The MediorNet system is a Laser class 1M product.



Caution	
	<p>A Class 1M laser is safe for all conditions of use except when passed through magnifying optics such as microscopes and telescopes. Class 1M lasers produce large-diameter beams, or beams that are divergent. The MPE for a Class 1M laser cannot normally be exceeded unless focusing or imaging optics are used to narrow the beam. If the beam is refocused, the hazard of Class 1M lasers may be increased and the product class may be changed. A laser can be classified as Class 1M if the total output power is below class 3B but the power that can pass through the pupil of the eye is within Class 1.</p>
<p>Do not view directly with optical instruments into the beam.</p>	

▼ **Battery Safety**

The XSS Cards are fitted with the following battery: Lithium Battery, type CR2032.

Warning	
	<p>Risk of explosion if battery is replaced by any other incorrect type.</p>
<p>Dispose of used batteries according to the instructions. Do not expose to high storage temperatures above 60°C (140°F).</p>	

▼ **Disposal**

Disposal of old Electrical & Electric Equipment (Applicable throughout the European Union and other European countries with separate collection programs).

	<p>This symbol, found on your product or on its packaging, indicates that this product should not be treated as household waste when you wish to dispose of it. Instead, it should be handed over to an applicable collection point for the recycling of electrical and electronic equipment. By ensuring this product is disposed of correctly, you will help prevent potential negative consequences to the environment and human health, which could otherwise be caused by inappropriate disposal of this product. The recycling of materials will help to conserve natural resources. For more detailed information about the recycling of this product please contact your local city office.</p>
--	---

USO RESTRITTO

1.2 Package Version

This Manual refers to the Package Version: 2.00.x

The "x" in the firmware version stands for any number between 0 and 99 and indicates bugfix versions. The relevant bug-fixes are described in the related release notes.

The Software Package contains the actual Version of:

- general Firmware
- FPGA
- CPLD
- Card-Firmware
- MediorWorks Software

A description of the single Versions is included in the Release-Notes.

Checking the Package Version

The Package Version is displayed in the top left corner on the website of the Frame.



Figure 1: Package Version

The Package Version is also visible by selecting the menu *System* -> *System Info* in MediorWorks or via *Device Browser* -> *Frame* -> *Context-Menu* -> *Status*.

USO RESTRITO

1.3 About MediorNet

MediorNet unleashes the true potential of fiber-optic signal transport, which will finally result in a complete new philosophy for broadcast, event, stadium or campus installations.

- signal transport
- signal routing
- signal processing and conversion into one integrated real-time network solution

MediorNet is not designed just for simple point-to-point links, it offers a real network solution. This includes signal routing, allowing the user to send any incoming signal to any output or even to multiple outputs by just a mouse-click or, even more convenient, controlled by a router control system.

Each MediorNet-Modular Frame provides a router for 32x32 720p/1080i signals, 160x160 SD-SDI signals, 27.000x27.000 AES signals or any combination of these.

With a network bandwidth of 50 Gbit/s MediorNet Compact provides enough capacity for bidirectional transport of 12 HD-SDI signals, dozens of MADI streams or Gbit-Ethernet signals, hundreds of Audio channels or intercom ports – ideal for streamlining the infrastructure of any mobile, studio or live event application.

MediorNet also includes broadcast-quality processing and conversion on board. These features are software-based so they can easily be expanded in the future without any changes to the hardware. Ultimately this will eliminate the need for external devices. All this results in a completely new approach to production environments, providing significant savings in infrastructure investments.

2 MediorNet-Modular

The MediorNet-Modular Frame can be rack-mounted in various positions, f.i. with all connectors on the front or on the rear side, or recessed to allow cabling from the front but without connectors or cables exceeding the rack's dimensions. The IEC connectors can be located front or rear independently from the other cabling. The MediorNet-Modular Frame is designed for mounting in a 19" rack with 2 RU dimensions.

The MediorNet-Modular Frame supports up to 8 client Cards.

Slots 3 and 8 are Low-Speed slots designed for low data rate signals such as Audio signals.

Slots 1, 5, 6, 7, 9 and 10 are High-Speed slots designed for high data rate signals such as Video signals.

The High-Speed slots are divided in two groups: slots 1, 5, 6 and 9 are 2x High-Speed slots and slots 7 and 10 are 4x High-Speed slots. The MN-LNK4 and the CWDM LINK-Cards can be only equipped in the 4x High-Speed slots.

Slots 2 & 4 are reserved for the Processing Card.

Possible Slot Assignment

Cards	Possible Slots
MN-XSS	2&4
MN-HD4I, MN-HD4O, MN-HDO-4IO, MN-HD(P)6, MN-LNK2, MN-ETH6, MN-GV2, MN-ST-AL2	1, 5, 6, 7, 9, 10
MN-LNK4, MN-LNK8-CWDM(80)(-H)	7, 10
MN-LNK10 CWDM, MN-LNK18 CWDM	7&10
MN-RN300, MN-MA2EO, MN-MIO (-E/-T)	3, 8

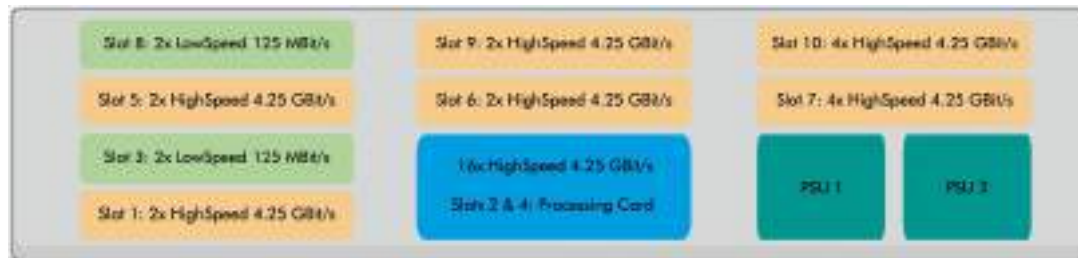

Figure 3: MediorNet-Modular Frame (front view)

USO RESTRITTO

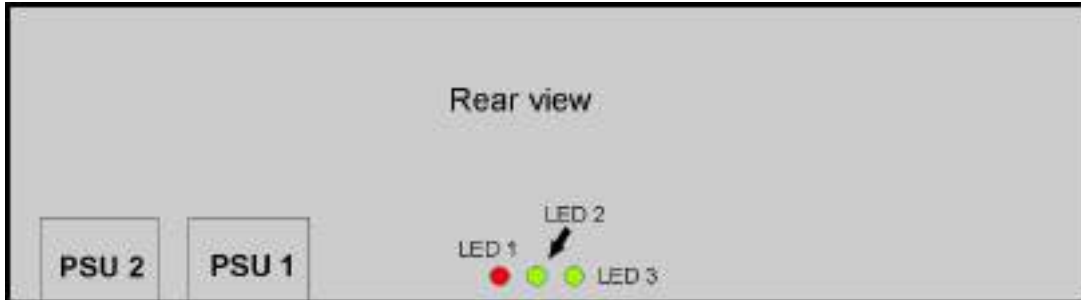

Figure 4: MediorNet-Modular Frame (rear view)

MediorNet-Modular Frame Status LEDs

LED	On	Off
1	No Processing Card inside or Processing Card malfunction	Status OK
2	Not used	Not used
3	12Vdc power present	No power present

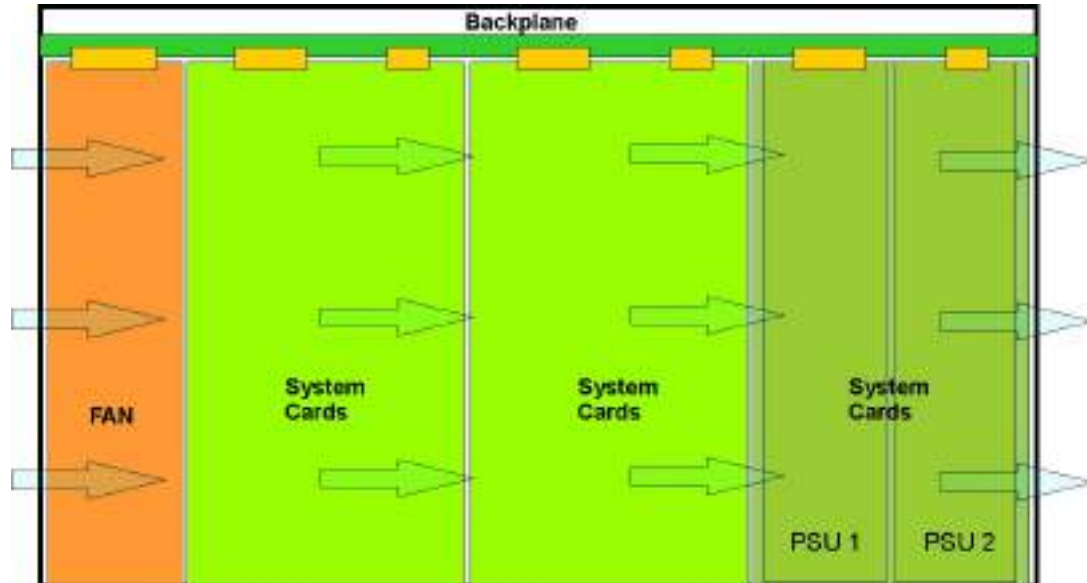

Figure 5: MediorNet-Modular Frame air flow (top view)

USO RESTRITTO

2.1 MN-PSU

The MediorNet-Modular Frame has two slots on the right bottom side for power supplies. It is recommended that both power supplies are installed and connected to separate AC power sources (90 ... 264Vac, 47 ... 63Hz).

The PSUF have their power cord connectors at the front of the Frame, while the PSUR have their power cord connectors at the rear side of the Frame.



Figure 6: MN-PSUF (front view)



Figure 7: MN-PSUR (rear view)

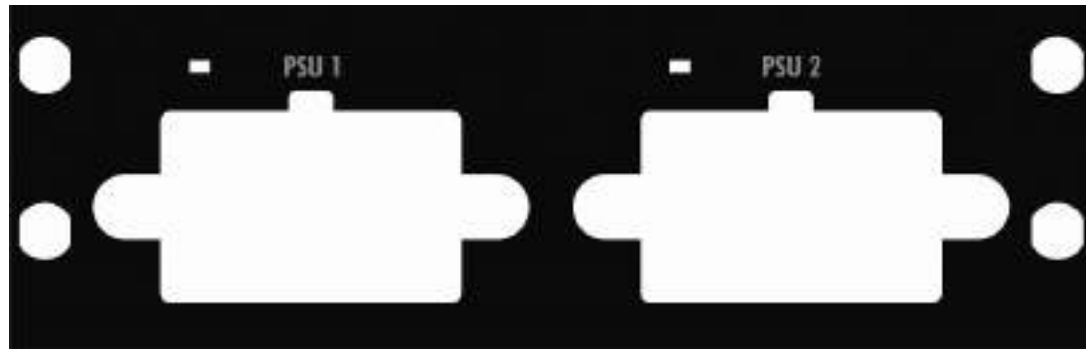

Figure 8: PSU front panel

An overview about all Status indicators can be found in chapter [Status LEDs](#).

USO RESTRITTO

2.2 MN-FAN

The MediorNet-Modular Frame has a unit with three high quality fans providing a silent but effective air flow through the Frame. The slot is located on the left side of the Frame. It is absolutely necessary that the fan box is correctly installed.

	Do not use the MN-FAN without dust filters. Do only use original dust filters from Riedel as they provide proper air flow and are not flammable.
--	--



Figure 9: MN-FAN



Figure 10: MN-FAN (front panel)

	If the status LED is orange, ensure the dust filter is clean and the air flow through the ventilation opening on the left and right side of the Frame is not blocked.
--	---

An overview about all Status indicators can be found in chapter [Status LEDs](#).

USO RESTRITO

2.3 MN-XSS

The MN-XSS Processing Card serves as the core of any MediorNet-Modular Frame. It includes extensive LED status indication for all Cards and modules. It must be equipped in Slot 2&4 in the MediorNet Frame. The Card features the following standard interfaces:

- 1 x 100BaseT Ethernet connection for configuration PCs or external router control systems
- 1 x 1000BaseT Gigabit Ethernet for PC networks (transparent tunneling)
- 2 x Artist intercom panel connectors (1x RJ45, 1x BNC, independently usable)
- 2 x bi-directional MADi interfaces (1x optical via SFP module, 1x electrical via two BNC connectors)
- 1 x Sync In & 1x Sync Out via BNC connectors for Frame synchronization

Each MN-XSS Card has an Ethernet MAC- and IP address.
The MN-XSS Card is set to "Zeroconf" by default (IP: 169.254.1.1).



Figure 11: MN-XSS (top view)

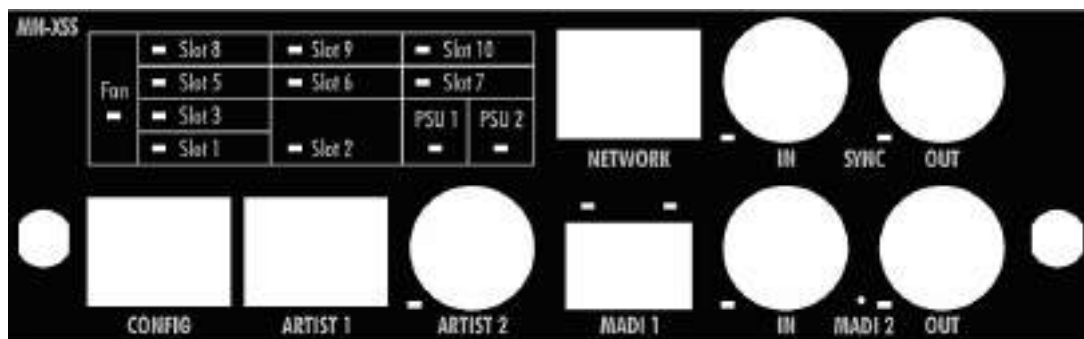
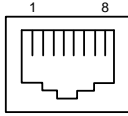

Figure 12: MN-XSS (front panel)

USO RESTRITO

▼ CONFIG Port

The CONFIG Port is used to configure the system. To configure the Frames it is sufficient to connect a PC to one Frame. All other Frames are configured over the fiber-network. For direct connection to a PC or to a network switch use any standard (straight-through) network patch cable. The MediorNet CONFIG Port is 100 Mbit, full-duplex compatible with auto sense functionality.



Pin	Signal	Standard color
1	TxD+	orange/white
2	TxD-	orange
3	RxD+	green/white
4	--	blue
5	--	blue/white
6	RxD-	green
7	--	brown/white
8	--	brown

Figure 13: MN-XSS Card CONFIG Port RJ-45pinout (8P8C)

▼ NETWORK Port

The NETWORK Port is used to tunnel a LAN over the MediorNet network. For a direct connection to a PC or to a network switch use any standard (straight-through) network patch cable. The MediorNet NETWORK Port is 1 Gbit, full-duplex compatible.

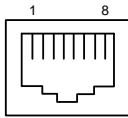

Pin	Signal	Standard color
1	BI_DA+	orange/white
2	BI_DA-	orange
3	BI_DB+	green/white
4	BI_DC+	blue
5	BI_DC-	blue/white
6	BI_DB-	green
7	BI_DD+	brown/white
8	BI_DD-	brown

Figure 14: MN-XSS Card NETWORK Port RJ-45pinout (8P8C)

▼ ARTIST Panel Ports

The ARTIST-Panel Ports are used to connect Artist panels to the MediorNet Frame. At each Frame, two Artist-Panels can be connected at the same time. One Artist-Panel can be connected via CAT5, one via BNC.

	<p>Use an X-over cable between the Artist Card "CAT5-108 G2 RC" and the ARTIST-Panel Port 1 to connect an Artist-Mainframe at the MediorNet Frame.</p> <p>Use a straight-through cable to connect an Artist-Panel at the ARTIST-Panel Port 1.</p>
---	---

For the ARTIST-Panel Ports the 2 channel mode is supported.

	<table border="1"> <thead> <tr> <th>Pin</th> <th>Signal</th> </tr> </thead> <tbody> <tr><td>1</td><td>RxD+</td></tr> <tr><td>2</td><td>RxD-</td></tr> <tr><td>3</td><td>TxD+</td></tr> <tr><td>4</td><td>--</td></tr> <tr><td>5</td><td>--</td></tr> <tr><td>6</td><td>TxD-</td></tr> <tr><td>7</td><td>--</td></tr> <tr><td>8</td><td>--</td></tr> </tbody> </table>	Pin	Signal	1	RxD+	2	RxD-	3	TxD+	4	--	5	--	6	TxD-	7	--	8	--	Z = 110 Ω
Pin	Signal																			
1	RxD+																			
2	RxD-																			
3	TxD+																			
4	--																			
5	--																			
6	TxD-																			
7	--																			
8	--																			

Figure 15: MN-XSS Card ARTIST panel 1 Port RJ45 pinout

	<table border="1"> <thead> <tr> <th>Pin</th> <th>Signal</th> </tr> </thead> <tbody> <tr><td>1</td><td>TxRx+</td></tr> <tr><td>2</td><td>TxRx-</td></tr> </tbody> </table>	Pin	Signal	1	TxRx+	2	TxRx-	Z = 75 Ω
Pin	Signal							
1	TxRx+							
2	TxRx-							

Figure 16: MN-XSS Card ARTIST panel 2 Port BNC pinout

USO RESTRITTO

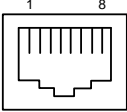
▼ MADI Ports

The MADI Ports are used to interface the MediorNet Frame to an Artist-Mainframe or external equipment. Each MADI Port supports up to 64 bidirectional Audio channels. The optical MADI Port supports single-mode and multi-mode SFP transceivers.

The original SFPs available from Riedel is highly recommended for use with the MADI Port as it provides the proper optical budget for other MADI devices.



Figure 17: SFP (front view, top view)

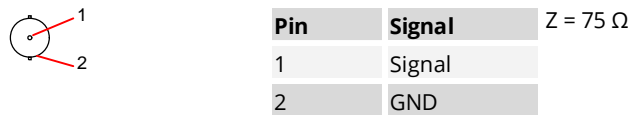

Figure 18: MN-XSS Card MADI 2 IN & OUT Port BNC pinout

▼ SYNC IN & SYNC OUT Ports

The SYNC IN Port is used to synchronize the system to an external Sync Source. The SYNC OUT Port is used to synchronize external systems to the Frame. MediorNet is able to create a Sync internally. For all supported Sync formats refer to chapter [Supported synchronization formats](#).

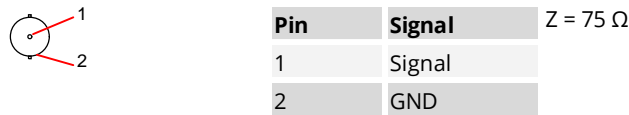

Figure 19: MN-XSS Card SYNC IN/OUT Port BNC pinout

An overview about all Status indicators can be found in chapter [Status LEDs](#).

USO RESTRITTO

2.4 MN-LNKx

The MN-LNK2 & MN-LNK4 LINK-Cards feature two/four SFP slots for single-mode and multi-mode SFP transceivers of any wavelength with 4.25 Gbit/s transfer rate and an electrical level of 3.3V. The Cards allow the interconnection of multiple MediorNet Frames via two/four bidirectional duplex fiber links.

The MN-LNK8/10/18 CWDM LINK-Cards feature integrated CWDM multiplexing/de-multiplexing. The Cards multiplex MediorNet 4.25 Gbit/s signals plus external fiber Ports onto one single-mode duplex fiber, accessible via LC connectors. The external fiber Ports are connected via LC connectors.

2.4.1 MN-LNK2

The LNK2 Card needs a 2xHigh-Speed Slot, so it can be placed in the slots 1, 5, 6, 7, 9 and 10. It occupies one slot.

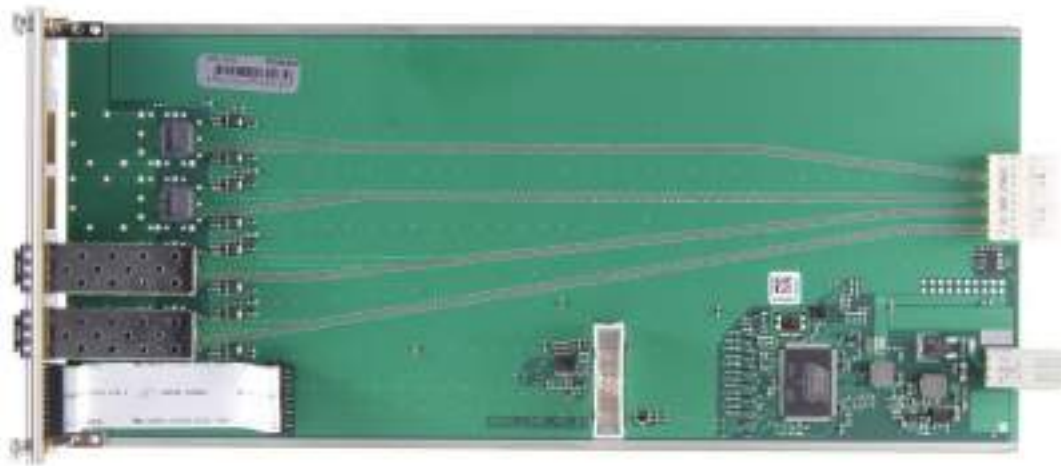

Figure 20: MN-LNK2 (top view)



Figure 21: MN-LNK2 (front panel)

The original fiber module available from Riedel is highly recommended for use with the MN-LNK2 fiber Ports.

An overview about all Status indicators can be found in chapter [Status LEDs](#).

2.4.2 MN-LNK4

The MN-LNK4 Card needs a 4xHigh-Speed Slot, so it can be placed in the slots 7 and 10. It occupies one slot. If placed in slot 1, 5, 6 or 9 only two of the four available High-Speed links (link 3 and 4) are supported.

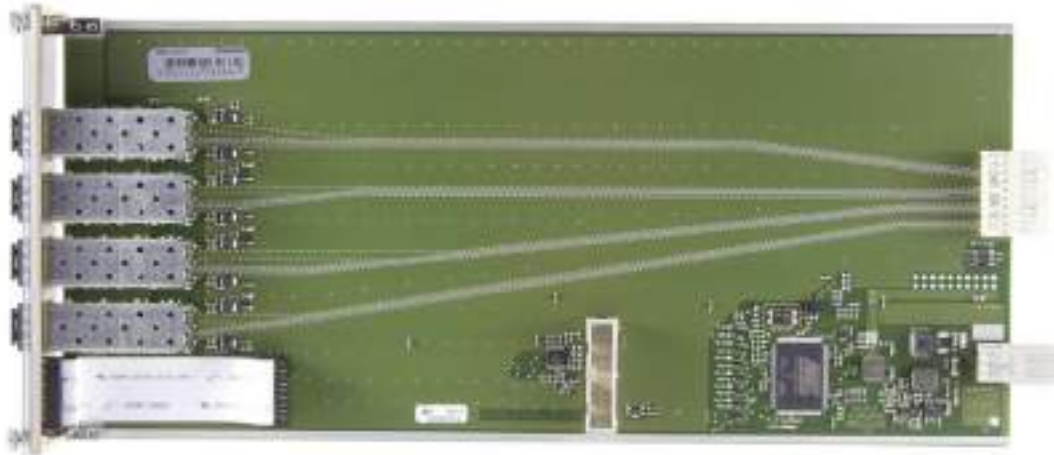

Figure 22: MN-LNK4 (top view)



Figure 23: MN-LNK4 (front panel)

The original fiber module available from Riedel is highly recommended for use with the MN-LNK4 fiber Ports.

An overview about all Status indicators can be found in chapter [Status LEDs](#).

USO RESTRITTO

2.4.3 MN-LNK8-CWDM(80)

The MN-LNK8-CWDM LINK-Card features integrated CWDM multiplexing/de-multiplexing. The Card multiplexes four MediorNet 4.25 Gbit/s signals plus four external fiber Ports onto one single-mode duplex fiber, accessible via LC connectors. The external fiber Ports are connected via four LC connectors. The MN-LNK8-CWDM Card supports single-mode SFP transceivers only.

The MN-LNK8-CWDM LINK-Card covers wavelengths from 1271 to 1411 nm.

It needs a 4xHigh-Speed Slot, so it can be placed in the slots 7 and 10. It occupies one slot.

While the MN-LNK8-CWDM version can transport data over a fiber length of up to 40km, the MN-LNK8-CWDM80 version is equipped with high power SFPs for a maximum fiber length of 80km.

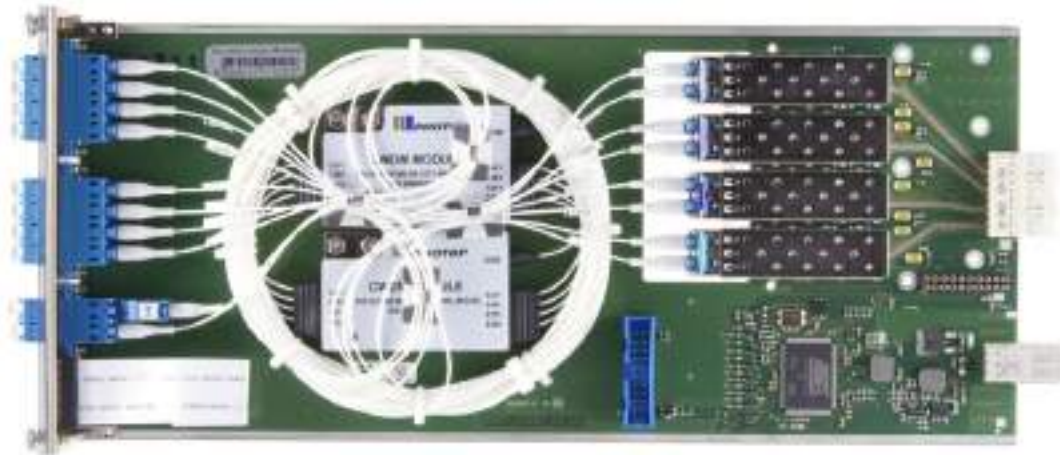

Figure 24: MN- LNK8-CWDM (top view)



Figure 25: MN- LNK8-CWDM (front panel)

Each Port for external fiber signals is specified for one specific wavelength as listed below:

Port	Wavelength
1	1351 nm
2	1371 nm
3	1391 nm
4	1411 nm

An overview about all Status indicators can be found in chapter [Status LEDs](#).

USO RESTRITO

2.4.4 MN-LNK8-CWDM(80)-H

The MN-LNK8-CWDM-H LINK-Card features integrated CWDM multiplexing/de-multiplexing. The Card multiplexes four MediorNet 4.25 Gbit/s signals plus four external fiber Ports onto one single-mode duplex fiber, accessible via LC connectors. The external fiber Ports are connected via four LC connectors. The MN-LNK8-CWDM-H Card supports single-mode SFP transceivers only.

The MN-LNK8-CWDM-H LINK-Card covers wavelengths from 1471 to 1611 nm.

It needs a 4xHigh-Speed Slot, so it can be placed in the slots 7 and 10. It occupies one slot.

While the MN-LNK8-CWDM-H version can transport data over a fiber length of up to 40km, the MN-LNK8-CWDM80-H version is equipped with high power SFPs for a maximum fiber length of 80km.

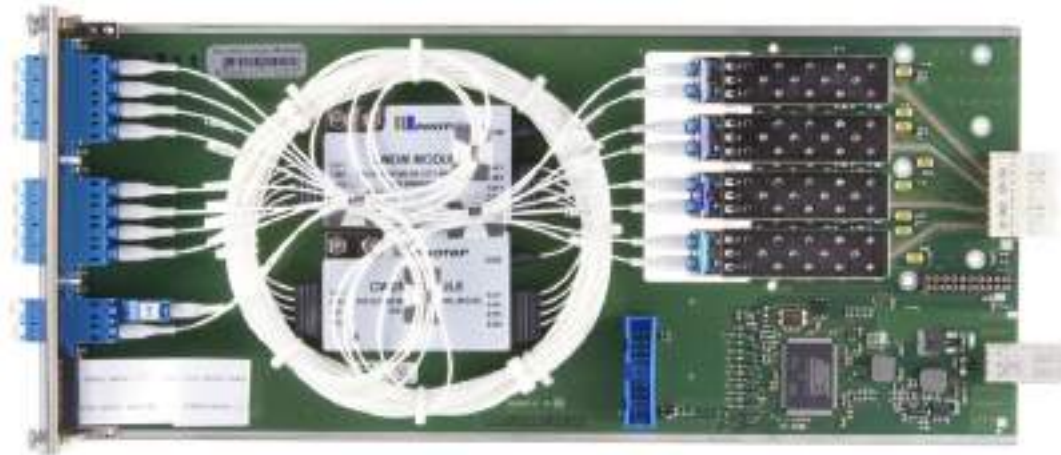

Figure 26: MN- LNK8-CWDM-H (top view)



Figure 27: MN- LNK8-CWDM-H (front panel)

Each Port for external fiber signals is specified for one specific wavelength as listed below:

Port	Wavelength
1	1551 nm
2	1571 nm
3	1591 nm
4	1611 nm

An overview about all Status indicators can be found in chapter [Status LEDs](#).

USO RESTRITO

2.4.5 MN-LNK10-CWDM

The MN-LNK10 CWDM LINK-Card features integrated CWDM multiplexing/de-multiplexing. The Card multiplexes eight bidirectional MediorNet 4.25 Gbit/s signals plus two external fiber Ports onto one single-mode duplex fiber, accessible via LC connector. The external fiber Ports are connected via two LC connectors. The MN-LNK10 CWDM Card supports single-mode SFP transceivers only. It needs two 4xHigh-Speed Slots, so it must be placed in slot 7&10.



Figure 28: MN- LNK10-CWDM (top view)

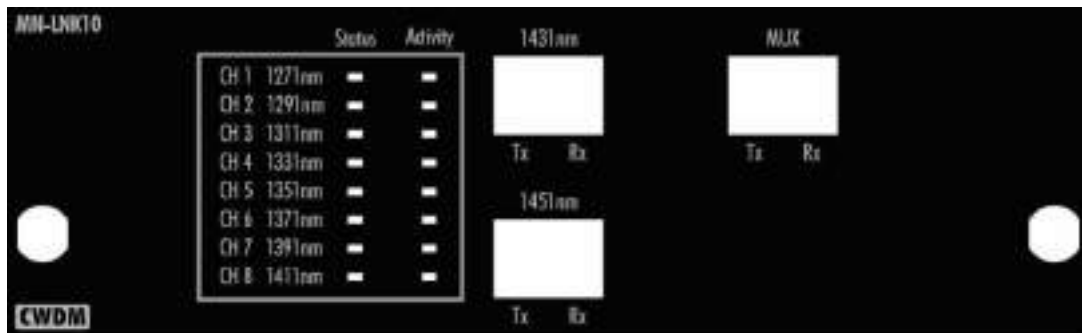

Figure 29: MN- LNK10-CWDM (front panel)

Each Port for external fiber signals is specified for one specific wavelength as listed below:

Port	Wavelength
1	1431 nm
2	1451 nm

An overview about all Status indicators can be found in chapter [Status LEDs](#).

USO RESTRITO

2.4.6 MN-LNK18-CWDM

The MN-LNK18 CWDM LINK-Card features integrated CWDM multiplexing/de-multiplexing. The Card multiplexes eight MediorNet 4.25 Gbit/s signals plus up to ten additional (already multiplexed) external fiber Ports via an ADD Port onto one single-mode duplex fiber, accessible via LC connector and transporting up to 76.5 Gbit/s. The MN-LNK18 CWDM Card supports single-mode SFP transceivers only. It needs two 4xHigh-Speed Slots, so it must be placed in slot 7&10.

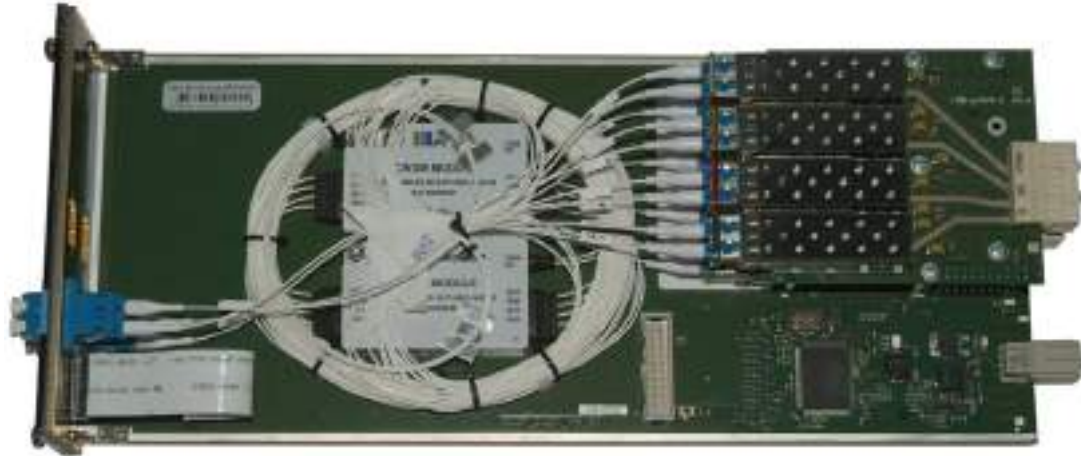

Figure 30: MN- LNK18-CWDM (top view)

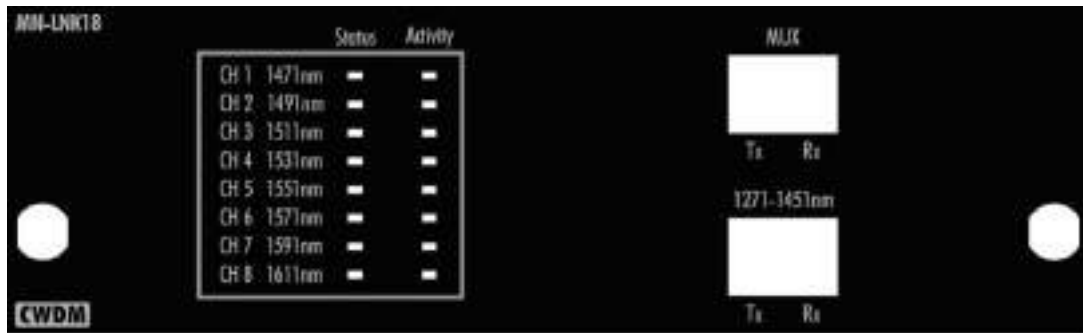

Figure 31: MN- LNK18-CWDM (front panel)

Ten additional (already multiplexed) external wavelengths can be multiplexed via one LC connector:

Port	Wavelength	Port	Wavelength
1	1271 nm	6	1371 nm
2	1291 nm	7	1391 nm
3	1311 nm	8	1411 nm
4	1331 nm	9	1431 nm
5	1351 nm	10	1451 nm

An overview about all Status indicators can be found in chapter [Status LEDs](#).

USO RESTRITO

2.5 Media Cards

MediorNet-Modular Frames can be easily configured with the input and output Cards needed for a specific installation. Various Media Cards support multiple Video standards and on-board signal processing and conversion, reducing the portfolio of Cards to a minimum. These signal standards and processing features can be updated via software, securing the hardware investment for future developments.

2.5.1 MN-HD4I

The MN-HD4I Card provides four inputs with BNC connectors for four HD/SD-SDI/ASI or two 3G-SDI Video sources. Each input operates independently and is equipped with features like format detection and Audio De-Embedder functionality. The MN-HD4I Card needs a 2xHigh-Speed Slot, so it can be placed in the slots 1, 5, 6, 7, 9 and 10.



Figure 32: MN-HD4I (top view)

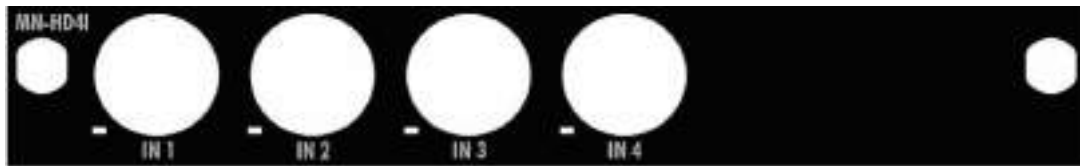

Figure 33: MN-HD4I (front panel)



Pin	Signal	Z = 75 Ω
1	Signal	
2	GND	

Figure 34: MN-HD4I Card Video Port BNC pinout

An overview about all Status indicators can be found in chapter [Status LEDs](#).

USO RESTRITTO

2.5.2 MN-HD40

The MN-HD40 Card provides four outputs with BNC connectors for four HD/SD-SDI/ASI or two 3G-SDI Video sources. Each output operates independently and is equipped with features like format detection, frame sync and Audio Embedder functionality.

The MN-HD40 Card needs a 2xHigh-Speed Slot, so it can be placed in the slots 1, 5, 6, 7, 9 and 10.



Figure 35: MN-HD40 (top view)

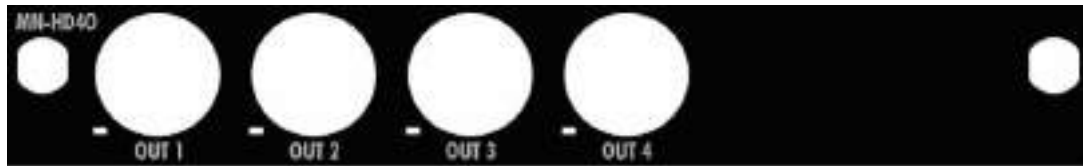

Figure 36: MN-HD40 (front panel)



Pin	Signal	Z = 75 Ω
1	Signal	
2	GND	

Figure 37: MN-HD40 Card Video Port BNC pinout

An overview about all Status indicators can be found in chapter [Status LEDs](#).

USO RESTRITTO

2.5.3 MN-HDO-4IO

The MN-HDO-4IO Card provides four in-/outputs with SFP connectors. Each port can be used simultaneously for Video sources and destinations (3G/HD/SD-SDI/ASI Video signals). Each in-/output operates independently and is equipped with features like format detection, frame sync and Audio Embedder/De-Embedder functionality. The MN-HDO-4IO Card needs a 2xHigh-Speed Slot, so it can be placed in the slots 1, 5, 6, 7, 9 and 10.



Figure 38: MN-HDO-4IO (top view)



Figure 39: MN-HDO-4IO (front panel)

An overview about all Status indicators can be found in chapter [Status LEDs](#).

USO RESTRITO

2.5.4 MN-HD6

The MN-HD6 Card provides six BNC connectors.

The two ports on the left side are input ports, the two middle ones are output ports and the two on the right side can be configured independently either as input or as output in the MediorWorks Software.

The Card supports up to 4 HD/SD-SDI/ASI or 2 3G Video inputs and up to 4 HD/SD-SDI/ASI or 2 3G Video outputs.

Each port operates independently and is equipped with features like format detection, frame sync and Audio Embedder/De-Embedder functionality. The MN-HD6 Card needs a 2xHigh-Speed Slot, so it can be placed in the slots 1, 5, 6, 7, 9 and 10.



Figure 40: MN-HD6 (top view)



Figure 41: MN-HD6 (front panel)



Pin	Signal	Z = 75 Ω
1	Signal	
2	GND	

Figure 42: MN-HD6 Video Port BNC pinout

An overview about all Status indicators can be found in chapter [Status LEDs](#).

USO RESTRITO

2.5.5 MN-HDP6

The MN-HDP6 Card provides six BNC connectors.

The two ports on the left side are input ports, the two middle ones are output ports and the two on the right side can be configured independently either as input or as output in the MediorWorks Software.

The Card supports up to 4 HD/SD-SDI/ASI or 2 3G Video inputs and up to 4 HD/SD-SDI/ASI or 2 3G Video outputs.

Each port operates independently and is equipped with features like format detection, frame sync, Audio Embedder/De-Embedder functionality, conversion features and QUAD-split Video output. The MN-HDP6 Card needs a 2xHigh-Speed Slot, so it can be placed in the slots 1, 5, 6, 7, 9 and 10. A maximum amount of 3 MN-HDP6 Cards can be equipped in one MediorNet-Modular Frame.



Figure 43: MN-HDP6 (top view)



Figure 44: MN-HDP6 (front panel)



Pin	Signal	Z = 75 Ω
1	Signal	
2	GND	

Figure 45: MN-HDP6 Video Port BNC pinout

An overview about all Status indicators can be found in chapter [Status LEDs](#).

USO RESTRITO

2.5.6 MN-MA2EO

The MN-MA2EO Card provides one electrical MADI Port via two BNC connectors and one optical MADI Port via SFP module for a 2x64 Channel MADI interface. The MN-MA2EO Card needs a Low-Speed Slot, so it can be placed in the slots 3 and 8.

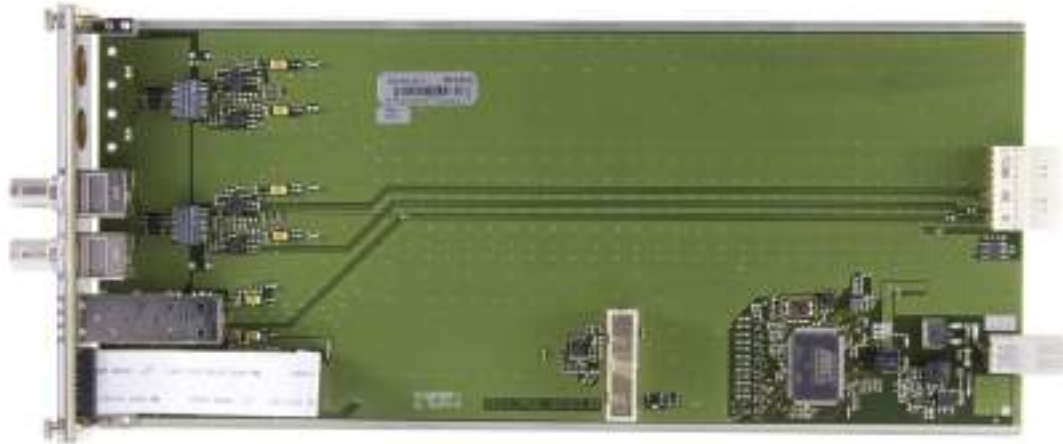

Figure 46: MN-MA2EO (top view)



Figure 47: MN-MA2EO (front panel)



Pin	Signal	Z = 75 Ω
1	Signal	
2	GND	

Figure 48: MN-MA2EO Card MADI Port BNC pinout

An overview about all Status indicators can be found in chapter [Status LEDs](#).

USO RESTRITTO

2.5.7 MN-RN300

The MN-RN300 Card provides an up-link and down-link CAT5 connector for Riedel RockNet digital Audio network. This provides a maximum Audio break-out of up to 128 channels. RockNet provides a redundant CAT5 ring network for the distribution of Audio and delivers state-of-the-art Audio interfacing for any MediorNet installation. The MN-RN300 Card needs a Low-Speed Slot, so it can be placed in the slots 3 and 8.



 This Card does not provide *remote power* for the RockNet ring.



Figure 49: MN-RN300 (top view)

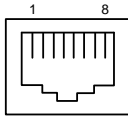

Figure 50: MN-RN300 (front panel)

 For further configuration please refer to the RockNet manual.

USO RESTRITO

▼ NETWORK Port



Pin	Signal	Standard color
1	ETHTX +	orange/white
2	ETHTX -	orange
3	ETHRX +	green/white
4	--	blue
5	--	blue/white
6	ETHRX -	green
7	--	brown/white
8	--	brown

Figure 51: MN-RN300 Card RockNet NETWORK Port RJ-45 pinout

▼ USB Port

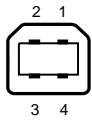

Pin	Signal	Standard color
1	NC	red
2	RDM	white
3	RDP	green
4	GND	black

Figure 52: MN-RN300 Card RockNet USB pinout

USO RESTRITTO

▼ LINK IN Port

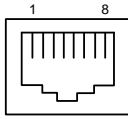

Pin	Signal	Standard color
1	LNKI_TX0 +	orange/white
2	LNKI_TX0 -	orange
3	LNKI_RX0 +	green/white
4	LNKI_TX1 +	blue
5	LNKI_TX1 -	blue/white
6	LNKI_RX0 -	green
7	LNKI_RX1 +	brown/white
8	LNKI_RX1 -	brown

Figure 53: MN-RN300 Card RockNet LINK IN Port RJ-45 pinout

▼ LINK OUT Port

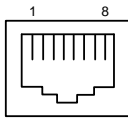

Pin	Signal	Standard color
1	LNKI_RX0 +	orange/white
2	LNKI_RX0 -	orange
3	LNKI_TX0 +	green/white
4	LNKI_RX1 +	blue
5	LNKI_RX1 -	blue/white
6	LNKI_TX0 -	green
7	LNKI_TX1 +	brown/white
8	LNKI_TX1 -	brown

Figure 54: MN-RN300 Card RockNet LINK OUT Port RJ-45 pinout

An overview about all Status indicators can be found in chapter [Status LEDs](#).

USO RESTRITO

2.5.8 MN-MBP

The MN-MBP (Multi Breakout Panel) is an external box and can be mounted in a 19" Rack. The panel provides low speed interface breakouts for the following signals:

- 12 x GPI Inputs
- 12 x GPI Outputs
- 4 x RS-422
- 8 x AES
- 8 x AIO

Two straight-through cables with HDsub44 connectors – male to female – are required for the connection to either the [MN-MIO-E](#) or [MN-MIO-T](#) Card in the MediorNet system. The connectors are male & female due to reverse plug protection



Figure 55: MN-MBP (top view)



Figure 56: MN-MBP (front panel)

USO RESTRITO

▼ GPI Input Port

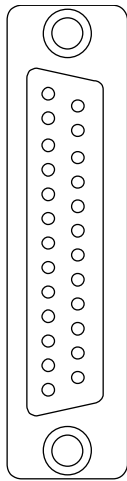

Pin	Signal
1	GP-IN1-P
2	GP-IN2-P
3	GP-IN3-P
4	GP-IN4-P
5	GP-IN5-P
6	GP-IN6-P
7	GP-IN7-P
8	GP-IN8-P
9	GP-IN9-P
10	GP-IN10-P
11	GP-IN11-P
12	GP-IN12-P
13	GND

Pin	Signal
14	GP-IN1-N
15	GP-IN2-N
16	GP-IN3-N
17	GP-IN4-N
18	GP-IN5-N
19	GP-IN6-N
20	GP-IN7-N
21	GP-IN8-N
22	GP-IN9-N
23	GP-IN10-N
24	GP-IN11-N
25	GP-IN12-N

female

Figure 57: MN-MBP Card GPI Input Port Sub-D-25 female pinout

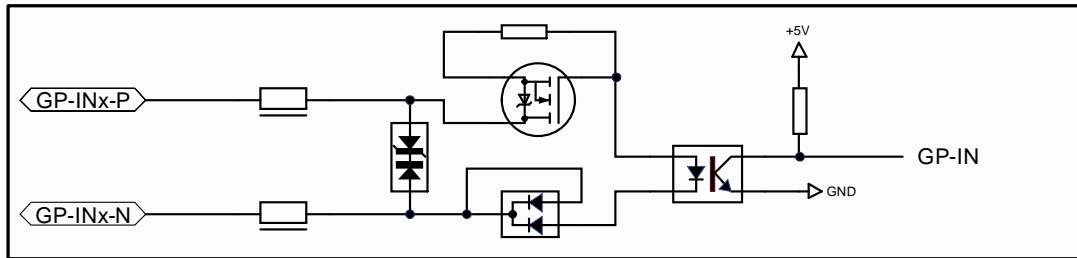
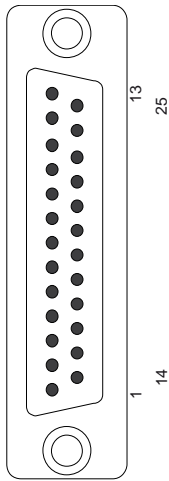

Figure 58: MN-MBP Card GPI Input Port Schematic

The input voltage range of the GPI Input is +5 ... +48 Vdc (5 mA).

USO RESTRITTO

▼ GPI Output Port



male

Pin	Signal
1	GP-OUT1-P
2	GP-OUT2-P
3	GP-OUT3-P
4	GP-OUT4-P
5	GP-OUT5-P
6	GP-OUT6-P
7	GP-OUT7-P
8	GP-OUT8-P
9	GP-OUT9-P
10	GP-OUT10-P
11	GP-OUT11-P
12	GP-OUT12-P
13	GND

Pin	Signal
14	GP-OUT1-N
15	GP-OUT2-N
16	GP-OUT3-N
17	GP-OUT4-N
18	GP-OUT5-N
19	GP-OUT6-N
20	GP-OUT7-N
21	GP-OUT8-N
22	GP-OUT9-N
23	GP-OUT10-N
24	GP-OUT11-N
25	GP-OUT12-N

Figure 59: MN-MBP Card GPI Output Port Sub-D-25 male pinout

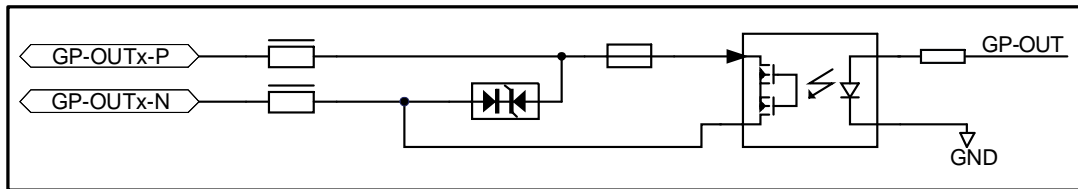
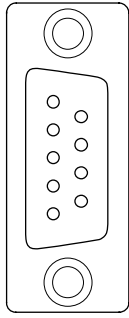

Figure 60: MN-MBP Card GPI Output Port Schematic

The maximum input voltage of the GPI Output is 48 Vdc (max. 140 mA).

USO RESTRITTO

▼ SERIAL Port



female

Pin	Signal
1	RS422-TX-N
2	--
3	RS422-RX-P
4	RS422-TX-P
5	GND
6	RS422-RX-N
7	--
8	--
9	--

Figure 61: MN-MBP Card Serial 1...4 Port Sub-D-9 female pinout

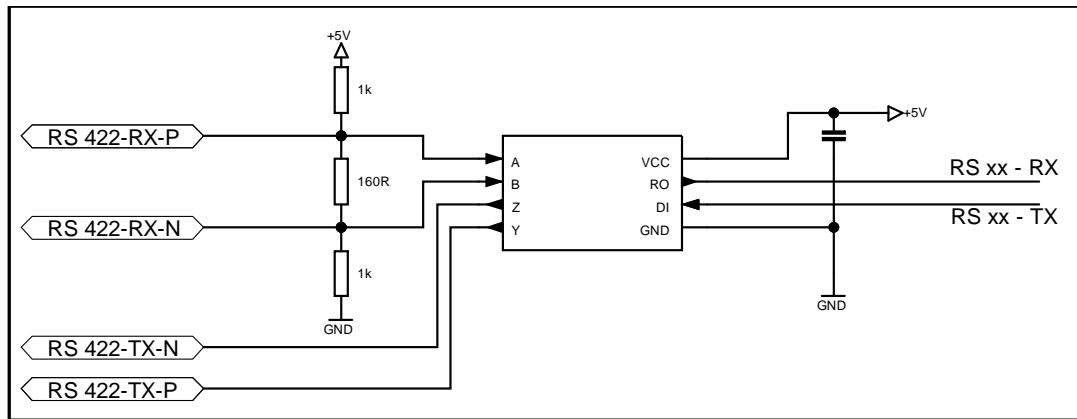
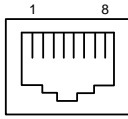

Figure 62: MN-MBP Card Serial Port Schematic

USO RESTRITTO

▼ AES Port



Pin	Signal	Standard color
1	AES-RX-P	orange/white
2	AES-RX-N	orange
3	AES-TX-P	green/white
4	--	blue
5	--	blue/white
6	AES-TX-N	green
7	--	brown/white
8	--	brown

Figure 63: MN-MBP Card AES Port RJ-45 pinout

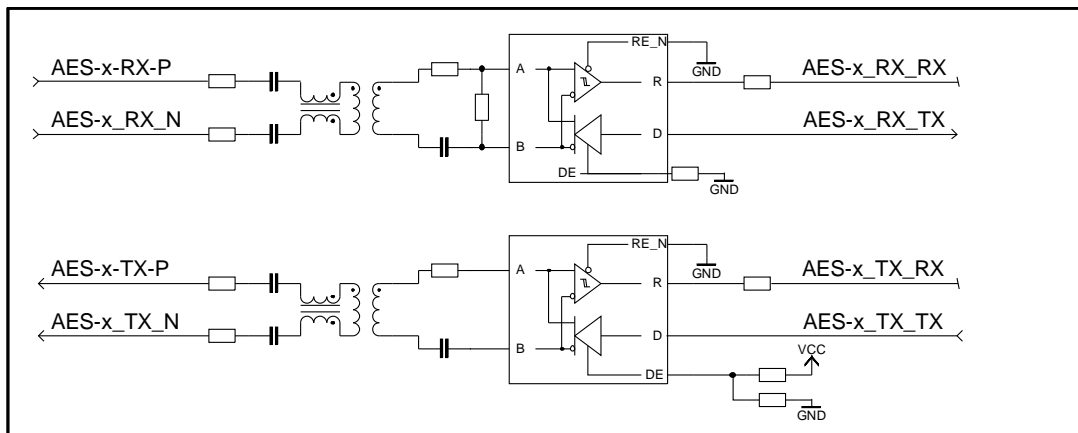

Figure 64: MN-MBP Card AES Port Schematic



The circuit is located on in the MN-MIO(-E/-T).
The signals of the RJ45 ports are passed through the MN-MBP.

USO RESTRITTO

▼ AIO Port

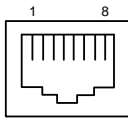

Pin	Signal	Standard color
1	--	orange/white
2	--	orange
3	--	green/white
4	AIO-RX-P	blue
5	AIO-RX-N	blue/white
6	--	green
7	AIO-TX-P	brown/white
8	AIO-TX-N	brown

Figure 65: MN-MBP Card AIO Port RJ-45 pinout

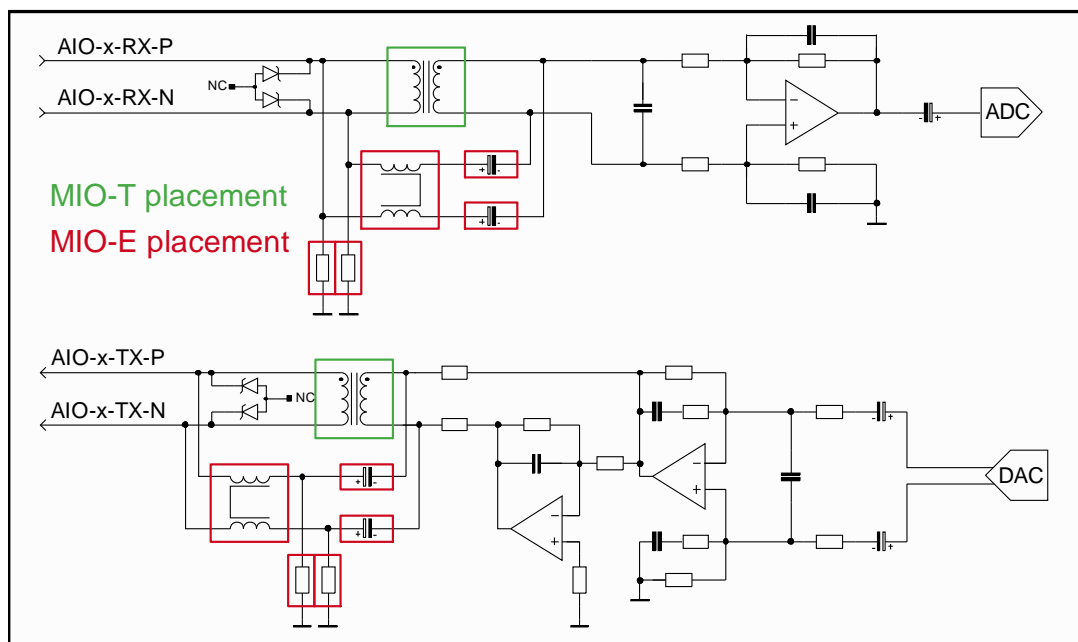

Figure 66: MN-MBP Card AIO Port Schematic



The circuit is located on in the MN-MIO(-E/-T).
The signals of the RJ45 ports are passed through the MN-MBP.

USO RESTRITTO

▼ CON Port

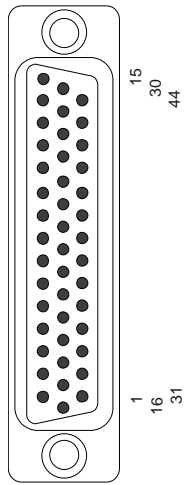

male

Pin	Signal	Pin	Signal	Pin	Signal
1	AIO-8-RX-P	16	AIO-8-TX-P	31	AIO-8-TX-N
2	AIO-8-RX-N	17	AIO-7-RX-P	32	AIO-7-RX-N
3	AIO-6-TX-P	18	AIO-7-TX-N	33	AIO-7-TX-P
4	AIO-6-TX-N	19	AIO-6-RX-N	34	AIO-6-RX-P
5	AIO-5-RX-P	20	AIO-5-TX-P	35	AIO-5-TX-N
6	+5V	21	AIO-5-RX-N	36	GND
7	Reserved	22	GND	37	Reserved
8	Reserved	23	Reserved	38	Reserved
9	AES-8-RX-P	24	Reserved	39	AES-8-TX-N
10	AES-8-RX-N	25	AES-8-TX-P	40	AES-7-RX-P
11	AES-6-TX-P	26	AES-7-RX-N	41	AES-7-TX-N
12	AES-6-TX-N	27	AES-7-TX-P	42	AES-6-RX-P
13	AES-5-RX-P	28	AES-6-RX-N	43	AES-5-TX-N
14	AES-5-RX-N	29	AES-5-TX-P	44	--
15	--	30	--		

Figure 67: MN-MBP Card CON1 Port HD-Sub44 male pinout

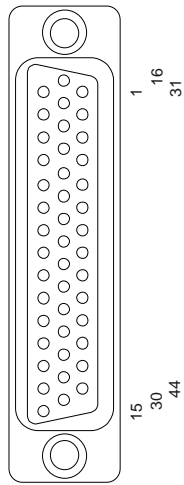

female

Pin	Signal	Pin	Signal	Pin	Signal
1	AIO-4-RX-P	16	AIO-4-TX-P	31	AIO-4-TX-N
2	AIO-4-RX-N	17	AIO-3-RX-P	32	AIO-3-RX-N
3	AIO-2-TX-N	18	AIO-3-TX-P	33	AIO-3-TX-N
4	AIO-2-TX-P	19	AIO-2-RX-N	34	AIO-2-RX-P
5	AIO-1-RX-P	20	AIO-1-TX-P	35	AIO-1-TX-N
6	+5V	21	AIO-1-RX-N	36	GND
7	Reserved	22	GND	37	Reserved
8	Reserved	23	Reserved	38	Reserved
9	AES-4-RX-P	24	Reserved	39	AES-4-TX-N
10	AES-4-RX-N	25	AES-4-TX-P	40	AES-3-RX-P
11	AES-2-TX-P	26	AES-3-RX-N	41	AES-3-TX-N
12	AES-2-TX-N	27	AES-3-TX-P	42	AES-2-RX-P
13	AES-1-RX-P	28	AES-2-RX-N	43	AES-1-TX-N
14	AES-1-RX-N	29	AES-1-TX-P	44	--
15	--	30	--		

Figure 68: MN-MBP Card CON2 Port HD-Sub44 female pinout

The Multi Breakout Panel has no LED indications.

USO RESTRITO

2.5.9 MN-MIO-E

The MN-MIO-E Card serves the connection to the Multi-Breakout-Panel ([MN-MBP](#)).

The transformation of the signals on the MN-MIO Card depends on the Card version (-E or -T) and is done either electronically or by inductors. On this Card it is done electronically.

Two straight-through cables with HDsub44 connectors – male to female – are required for the connection to the [MN-MBP](#).

The connectors are male & female due to reverse plug protection.

The MN-MIO-E Card needs a Low-Speed Slot, so it can be placed in the slots 3 and 8.



Figure 69: MN-MIO-E (top view)



Figure 70: MN-MIO-E (front panel)

USO RESTRITO

▼ CON Port

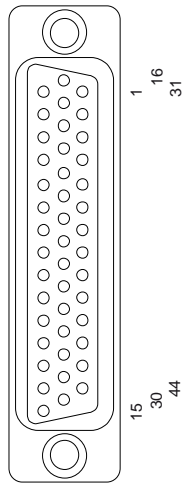

female

Pin	Signal	Pin	Signal	Pin	Signal
1	AIO-8-RX-P	16	AIO-8-TX-P	31	AIO-8-TX-N
2	AIO-8-RX-N	17	AIO-7-RX-P	32	AIO-7-RX-N
3	AIO-6-TX-P	18	AIO-7-TX-N	33	AIO-7-TX-P
4	AIO-6-TX-N	19	AIO-6-RX-N	34	AIO-6-RX-P
5	AIO-5-RX-P	20	AIO-5-TX-P	35	AIO-5-TX-N
6	+5V	21	AIO-5-RX-N	36	GND
7	Reserved	22	GND	37	Reserved
8	Reserved	23	Reserved	38	Reserved
9	AES-8-RX-P	24	Reserved	39	AES-8-TX-N
10	AES-8-RX-N	25	AES-8-TX-P	40	AES-7-RX-P
11	AES-6-TX-P	26	AES-7-RX-N	41	AES-7-TX-N
12	AES-6-TX-N	27	AES-7-TX-P	42	AES-6-RX-P
13	AES-5-RX-P	28	AES-6-RX-N	43	AES-5-TX-N
14	AES-5-RX-N	29	AES-5-TX-P	44	--
15	--	30	--		

Figure 71: MN-MIO Card CON1 Port HD-Sub44 female pinout

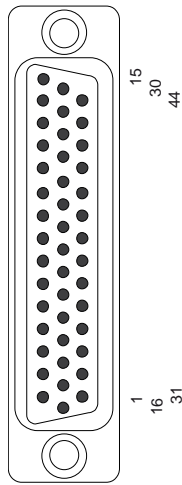

male

Pin	Signal	Pin	Signal	Pin	Signal
1	AIO-4-RX-P	16	AIO-4-TX-P	31	AIO-4-TX-N
2	AIO-4-RX-N	17	AIO-3-RX-P	32	AIO-3-RX-N
3	AIO-2-TX-N	18	AIO-3-TX-P	33	AIO-3-TX-N
4	AIO-2-TX-P	19	AIO-2-RX-N	34	AIO-2-RX-P
5	AIO-1-RX-P	20	AIO-1-TX-P	35	AIO-1-TX-N
6	+5V	21	AIO-1-RX-N	36	GND
7	Reserved	22	GND	37	Reserved
8	Reserved	23	Reserved	38	Reserved
9	AES-4-RX-P	24	Reserved	39	AES-4-TX-N
10	AES-4-RX-N	25	AES-4-TX-P	40	AES-3-RX-P
11	AES-2-TX-P	26	AES-3-RX-N	41	AES-3-TX-N
12	AES-2-TX-N	27	AES-3-TX-P	42	AES-2-RX-P
13	AES-1-RX-P	28	AES-2-RX-N	43	AES-1-TX-N
14	AES-1-RX-N	29	AES-1-TX-P	44	--
15	--	30	--		

Figure 72: MN-MIO Card CON2 Port HD-Sub44 male pinout

The MN-MIO-E Card has no LED indications.

USO RESTRITO

2.5.10 MN-MIO-T

The MN-MIO-T Card serves the connection to the Multi-Breakout-Panel ([MN-MBP](#)).

The transformation of the signals on the MN-MIO Card depends on the Card version (-E or -T) and is done either electronically or by inductors. On this Card it is done by inductors.

Two straight-through cables with HDsub44 connectors – male to female – are required for the connection to the [MN-MBP](#).

The connectors are male & female due to reverse plug protection.

The MN-MIO-T Card needs a Low-Speed Slot, so it can be placed in the slots 3 and 8.



Figure 73: MN-MIO-T (top view)



Figure 74: MN-MIO-T (front panel)

The pinout of the MN-MIO-T is identical to the [MN-MIO-E](#).

The MN-MIO-T Card has no LED indications.

USO RESTRITO

2.5.11 MN-ETH6

The MN-ETH6 Card provides six inputs with SFP connectors to tunnel a LAN over the MediorNet network. For a direct connection to a PC or to a network switch use any standard (straight-through) network patch cable. The MediorNet NETWORK Port is 1 Gbit, full-duplex compatible.

The MN-ETH6 Card needs a 2xHigh-Speed Slot, so it can be placed in the slots 1, 5, 6, 7, 9 and 10.



Figure 75: MN-ETH6 (top view)



Figure 76: MN-ETH6 (front panel)

An overview about all Status indicators can be found in chapter [Status LEDs](#).

USO RESTRITTO

2.5.12 MN-GV2

The MN-GV2 Card provides two ports with SFP connectors for the connection to Grass Valley Cameras or Grass Valley Base Stations.
 The MN-GV2 Card needs a 2xHigh-Speed Slot, so it can be placed in the slots 1, 5, 6, 7, 9 and 10.



Figure 77: MN-GV2 (top view)



Figure 78: MN-GV2 (front panel)

An overview about all Status indicators can be found in chapter [Status LEDs](#).

USO RESTRITTO

2.5.13 MN-ST-AL2

The MN-ST-AL2 Card provides two redundant ports for a direct interconnection between MediorNet Frames and Studer mixing consoles via Studer's A-Link protocol and bi-directional fiber connections. The MN-ST-AL2 Card needs a 2xHigh-Speed Slot, so it can be placed in the slots 1, 5, 6, 7, 9 and 10.



Figure 79: MN-ST-AL2 (top view)



Figure 80: MN-ST-AL2 (front panel)

An overview about all Status indicators can be found in chapter [Status LEDs](#).

USO RESTRITTO

2.6 MN-Modular Card Information

Card	Weight	Voltage	Fuse	Temperature-range	Connectors
MN-XSS	820 g	12 VDC	4 A, SMD	-5 ... +40°C	RJ45, SFP, BNC
MN-FAN	570 g	12 VDC	--	-5 ... +40°C	--
MN-PSUR MN-PSUF	760 g	90 ... 264 VAC, 47 ... 63 Hz	3 A	-5 ... +40°C	--
MN-LNK2 MN-LNK4	200 g	12 VDC	2 A, SMD	-5 ... +40°C	SFP
MN-LNK8-CWDM (80)(-H)	440 g	12 VDC	2 A, SMD	-5 ... +40°C	SFP
MN-LNK10 CWDM	610 g	12 VDC	2 A, SMD	-5 ... +40°C	SFP
MN-LNK18 CWDM	600 g	12 VDC	2 A, SMD	-5 ... +40°C	SFP
MN-HD4I MN-HD4O	350 g	12 VDC	2 A, SMD	-5 ... +40°C	BNC
MN-HDO-4IO	515 g	12 VDC	4 A, SMD	-5 ... +40°C	SFP
MN-HD6 MN-HDP6	595 g	12 VDC	4 A, SMD	-5 ... +40°C	BNC
MN-MA2EO	230 g	12 VDC	2 A, SMD	-5 ... +40°C	SFP, BNC
MN-RN300	225 g	12 VDC	2 A, SMD	-5 ... +40°C	RJ45, USB
MN-MBP	1500 g	5 VDC	0.3 A, SMD on MIO-E/T	-5 ... +40°C	SubD25, SubD9, RJ45, HDsub44
MN-MIO-E	270 g	12 VDC	2 A, SMD	-5 ... +40°C	HDsub44
MN-MIO-T	505 g	12 VDC	2 A, SMD	-5 ... +40°C	HDsub44
MN-ETH6	290 g	12 VDC	2 A, SMD	-5 ... +40°C	SFP
MN-GV2	280 g	12 VDC	2 A, SMD	-5 ... +40°C	SFP
MN-ST-AL2	280 g	12 VDC	2 A, SMD	-5 ... +40°C	SFP

USO RESTRITTO

2.7 MN-Modular Status LEDs

The meaning of the Status LEDs of the MediorNet Cards is listed in following table:
The MN-MIO-E & MN-MIO-T Card, as well as the MN-MBP have no Status LEDs.

▼ MN-XSS

LED	FAN
red	error
green	ok
orange	Warning, fan cannot reach maximum rotation
off	Processing Card not active

LED	PSU	Slot
red	error	Card failure / Card incompatible
green	ok	Active Card in slot
orange	--	Card started / Card update in progress
off	Processing Card not active	No active Card in slot

LED	NETWORK	CONFIG
green (left)	<i>on</i> : Ethernet connection ok <i>off</i> : no connection	<i>on</i> : Ethernet connection ok <i>off</i> : no connection
orange (right)	Traffic indicator, flashing while transmitting	<i>on</i> : Port is enabled <i>off</i> : Port is disabled (another port in the net is enabled)

LED	SYNC IN	SYNC OUT
red	Invalid Sync signal / Jitter too high	--
green	Connected SYNC signal is valid	SYNC OUT active
orange	Frame is Sync Master and in locking state	Frame is Sync Master
off	No SYNC signal at the input	Frame is Sync Slave and SYNC OUT is not active

LED	ARTIST 1	ARTIST 2
green	<i>on</i> : Input signal ok <i>off</i> : No / invalid signal at the input	Input signal ok
orange	<i>on</i> : Connection ok <i>off</i> : No connection	--
off	--	Invalid signal at the input

LED	MADI Output (left of MADI 1 & MADI 2)	MADI Input (right of MADI 1 & MADI 2)
red	--	SFP RX power too high/low (optical MADI only)
green	valid MADI signal output (at least 1 SubChannel)	valid MADI Input, signal locked
orange	Testsignals on all 64 SubChannels	--
off	no MADI signal output (MADI frame is still transmitted)	no valid MADI signal at the input

- optical MADI: Both LEDs are green for about 5 seconds while plugging an SFP

▼ MN-HD4I, MN-HD4O, MN-HDO-4IO

LED	Video Input	Video Output
red	invalid input Video format	invalid input Video format, no output
green	valid input Video format	valid Video signal
orange	test pattern active	test pattern active
off	no input signal	no output signal

- MN-HDO-4IO: Both LEDs are orange for about 3 seconds while plugging an SFP

▼ MN-HD6, MN-HDP6

LED	Video Input	Video Output
red	invalid input Video format	invalid input Video format, no output
green	valid input Video format	valid Video signal
orange	test pattern active	test pattern active
off	no input signal	no output signal
▲ green	port is input	--
▼ green	--	port is output

▼ MN-MA2EO

LED	MADI Output (left of SFP / BNC)	MADI Input (right of SFP / BNC)
red	--	SFP RX power too high/low (optical MADI only)
green	valid MADI signal output (at least 1 SubChannel)	valid MADI Input, signal locked
orange	Testsignals on all 64 SubChannels	--
off	no MADI signal output (MADI frame is still transmitted)	no valid MADI signal at the input

- optical MADI: Both LEDs are green for about 5 seconds while plugging an SFP

▼ MN-RN300

LED	LINK IN	LINK OUT	Master	48k	96k
green	communication ok synchronization ok		device is sync master	48k sampling rate	96k sampling rate
orange	communication ok Synchronization missing		non active sync master	--	--
off	no CAT.5 cable connected to neighbor device		device is sync slave	--> 96k sampling rate	--> 48k sampling rate

▼ MN-ETH6

LED	SFP Status (left)	SFP Activity (right)
red	--	Interrupted MediorNet connection present
green	Ethernet connection ok	Active MediorNet connection present
off	No Ethernet connection / no SFP plugged	No connection/ no SFP plugged

- While plugging a SFP module, both LEDs are orange until configuration succeeded
- If an incompatible SFP is plugged in, both LEDs light red

USO RESTRITO

▼ MN-GV2

LED	SFP Status (left)	SFP (right)
red	invalid input signal	reserved for future use
green	valid input signal	
off	no input signal	

- Both LEDs are orange for about 3 seconds while plugging an SFP

▼ MN-ST-AL2

LED	Output Status (left)	Input Status (right)
green	Output signal present	Link active
orange	--	Link up
off	no output signal	Link down

- Both LEDs are orange for about 3 seconds while plugging an SFP

▼ MN-LNKx

The Status LEDs are valid for all versions of LINK-Cards.

LED	Link Status (left)	Link Activity (right)
red	physical link up, MediorNet link up SFP RX power too high/low	Connections present and interrupted
green	physical link up, MediorNet link up	Connections present and ok
orange	physical link up, MediorNet link down	--
off	physical link down, MediorNet link down	no Connections present

- Both LEDs are green for about 5 seconds while plugging an SFP
- Both LEDs are red if an incompatible SFP is plugged

▼ MN-PSU

LED	Status
red	error
green	ok
off	Processing Card not active / no connection to mains (Frame has no power)

▼ MN-FAN

LED	Status
red	error
green	ok
orange	Warning, fan cannot reach maximum rotation
off	Processing Card not active



If the status LED is orange, ensure the dust filter is clean and the air flow through the ventilation opening on the left and right side of the Frame is not blocked.

3 MediorNet-Compact

The MediorNet-Compact are designed as light weight – maximum rugged units. This reliable system is equipped with one mains power supply, one input for an external (optional) 12Vdc power supply and high quality fans. The IEC-connector can be connected on the front or on the rear side and can be selected by a switch. The MediorNet-Compact is designed for a 19" rack installation and has a dimension of 3 RU.

MediorNet-Compact is available in 3 different versions: BASIC, PLUS and PRO. The differences are listed in following table.

	BASIC	PLUS	PRO
SD/HD/3G-SDI Video Inputs	2x	2x	4x
SD/HD/3G-SDI Video Outputs	2x	2x	4x
Display Port Outputs	2x	2x	2x
Analog Audio Mic/Line Inputs	2x	2x	4x
Analog Audio Line Outputs	2x	2x	4x
AES3 Digital Audio Ports	2x	2x	4x
MADI Digital Audio Ports (Optical)	1x	1x	2x
Gigabit Ethernet Ports	1x	1x	3x
Serial Interfaces (RS232 / 422 / 485 switchable)	1x	1x	2x
GPI Ports (Input / Output switchable)	--	--	10x
Sync Reference Input	1x	1x	1x
Sync Reference Outputs	1x	1x	3x
RockNet Interface	--	1x	1x
OLED Display	--	--	yes
Optional Modules			
8 Channel 3G/HD/SD-SDI/ASI Video Input	--	--	yes
8 Channel 3G/HD/SD-SDI/ASI Video Output *	--	--	yes
4 Channel Input, 4 Channel Output 3G/HD/SD-SDI/ASI Video	--	--	yes
4 Channel HDMI Video Input	--	--	yes
4 Channel HDMI Video Output	--	--	yes
2 Channel HDMI Video Input + 2 Channel HDMI Video Output	--	--	yes
Prepared for future option modules	yes	yes	yes

* 4x 3G/HD/SD-SDI/ASI and 4x HD/SD-SDI/ASI Outputs



Figure 81: MediorNet-Compact-PRO (front view)

USO RESTRITO



Figure 82: MediorNet-Compact-PRO (rear view)

Power Supply

All Compact devices have an internal power supply and contain two IEC connectors for the mains connection. One IEC connector is located in the front side (*Power-A*), the other one on the rear side (*Power-B*). A switch on the rear side selects the desired input. Additionally there is an XLR-4 plug on the rear side of the device to power the system via an external power supply (12Vdc / 7A). PSU redundancy is available by using one IEC mains plus an external power supply.



Figure 83: MN-Compact PSU

1	SELECT		selection of IEC connector POWER A (front side) or POWER B (rear side)
2	POWER A (front side)	IEC	connect via locking IEC connector of provided power supply cord
3	POWER B (rear side)	IEC	connect via locking IEC connector of provided power supply cord
4	EXT PSU	XLR-4	external power supply 12 VDC ±10%, max. ripple 250mV / 20 MHz, 8A constant / 14A peak (250ms)

USO RESTRITTO

Ventilation

The MN-Compact devices are equipped with 2 fans on the left and right side. The air flows from the left side through a dust filter to the right side.

	<p>If the status LED is orange, ensure the dust filter is clean and the air flow through the ventilation opening on the left and right side of the Frame is not blocked.</p>
---	--

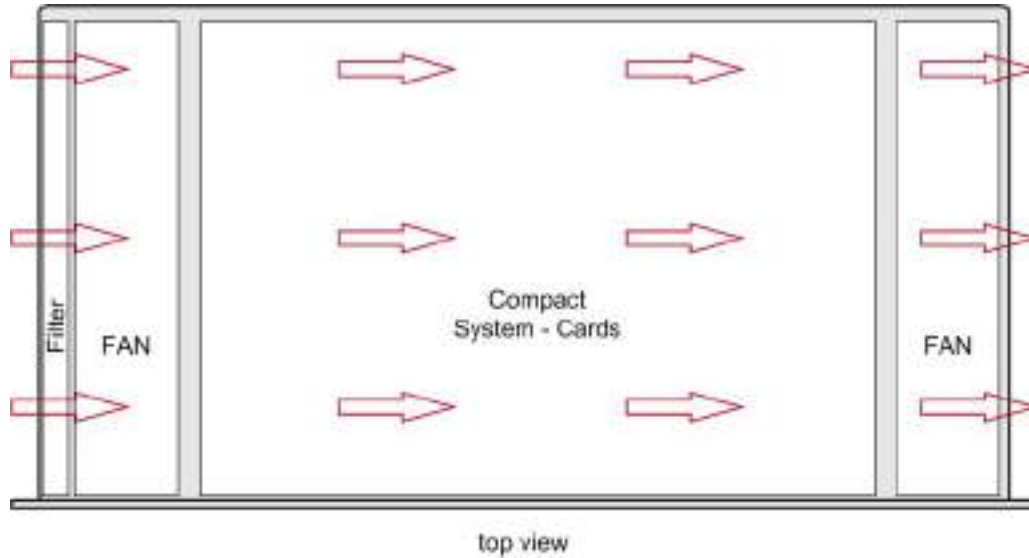



Figure 84: MediorNet-Compact air flow

RockNet

MN-Compact-PLUS and -PRO provide an up-link and down-link CAT5 connector for Riedel RockNet digital Audio network. This provides a maximum Audio break-out of up to 128 channels. RockNet provides a redundant CAT5 ring network for the distribution of Audio and delivers state-of-the-art Audio interfacing for any MediorNet installation.

	<p>MN-Compact does not provide <i>remote power</i> for the RockNet ring. For further configuration please refer to the RockNet manual.</p>
---	--

USO RESTRITO

Display

MN-Compact-PRO features an OLED display with integrated buttons on the left and right side. On the right side of the display is a rotary encoder with integrated push button located.

Following basic information can be displayed and changed:

1	Name	display of the local MN-Compact device name
2	Node ID	display and edit the local Node ID
3	IP Address	display and edit the local IP address and net mask
4	Serial/Package	display of the local MN-Compact serial number and the software version (package)
5	Temperature	display of the FPGA-, LINK- and Board-Temperature of the local MN-Compact
6	Riedel	logo
7	rx power	display of the actual optical receive power display of the minimum required receive power display of the maximum allowed receive power the power of each single High-Speed link (1 - 12) can be displayed
8	in usage	display of the actual usage of the receive direction the usage of each single High-Speed link (1 - 12) can be displayed
9	out usage	display of the actual usage of the transmit direction the usage of each single High-Speed link (1 - 12) can be displayed

The navigation through the display menu is shown in following table and figure.

Action	actual menu level	Response
rotating the rotary encoder	main menu	jump to the next menu entry
	<ul style="list-style-type: none"> • rx power • in usage • out usage 	selection of the High-Speed Link (1 - 12)
	<ul style="list-style-type: none"> • IP address • Node ID 	change the values in brackets
	Temperature	
push the rotary encoder button	main menu	jump into submenu
	<ul style="list-style-type: none"> • rx power • in usage • out usage 	<ul style="list-style-type: none"> • change of view • jump to main menu
	IP address	<ul style="list-style-type: none"> • jump to Netmask • jump to Apply • jump to main menu
	Node ID	<ul style="list-style-type: none"> • jump to Apply • jump to main menu
	Temperature	jump to next temperature
push the display buttons	main menu	jump to next menu entry
	<ul style="list-style-type: none"> • rx power • in usage • out usage 	<ul style="list-style-type: none"> • jump to <i>in usage</i> of the actual Link • jump to <i>out usage</i> of the actual Link • jump to main menu
	<ul style="list-style-type: none"> • IP address • Node ID 	<ul style="list-style-type: none"> • jump to next digit • change between <i>cancel / apply</i>
	Temperature	jump to main menu

USO RESTRITTO

USO RESTRITO

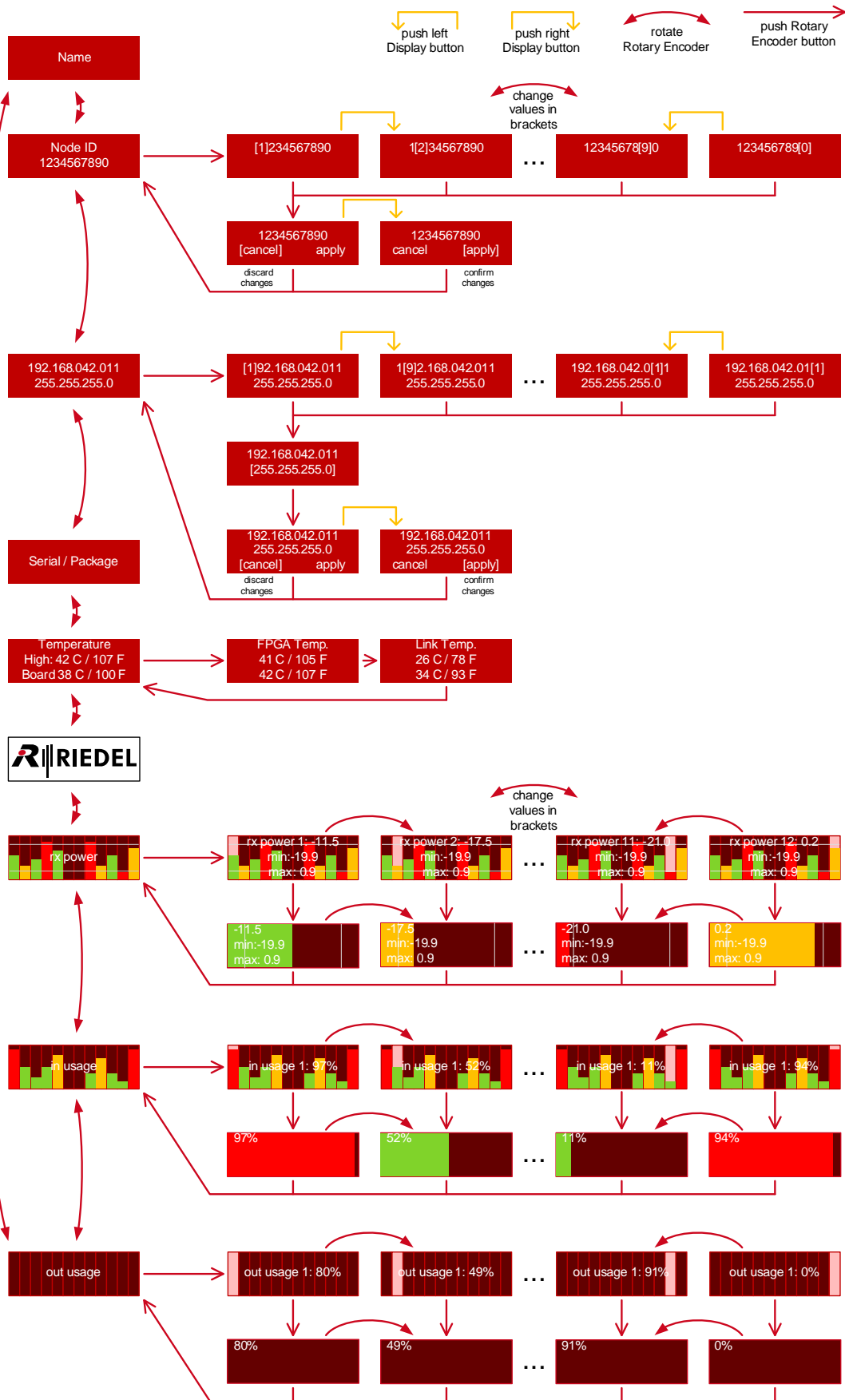
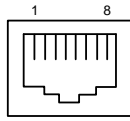

Figure 85: MN-Compact Display Menu structure

3.1 MN-Compact Ports

▼ CONFIG Port

The CONFIG Port is used to configure the system. To configure the Frames it is sufficient to connect a PC to one Frame. All other Frames are configured over the fiber-network. The MediorNet CONFIG Port is 100 Mbit, full-duplex compatible with auto sense functionality.



Pin	Signal	Standard color
1	TxD+	orange/white
2	TxD-	orange
3	RxD+	green/white
4	--	blue
5	--	blue/white
6	RxD-	green
7	--	brown/white
8	--	brown

Figure 86: MN-Compact CONFIG Port RJ-45 pinout

▼ SYNC IN & SYNC OUT Ports

The SYNC IN Port is used to synchronize the system to an external Sync. The SYNC OUT Port is used to synchronize external systems with the Frame. MediorNet is able to create a Sync internally. For all supported Sync formats refer to chapter [Supported synchronization formats](#). MN-Compact-PRO provides 1 input and 3 outputs. All outputs distribute the same signal and cannot be configured independently. MN-Compact-BASIC and -PLUS provide 1 input and 1 output.



Pin	Signal	Z = 75 Ω
1	Signal	
2	GND	

Figure 87: MN-Compact SYNC IN/OUT Port BNC pinout

▼ SDI IN & SDI OUT Port

MN-Compact-PRO provides 4 (BASIC/PLUS: 2) BNC in-/outputs for 4 3G/HD/SD-SDI/ASI Video signals. Each input operates independently and is equipped with features like format detection, frame sync, On-Screen-Display and Audio (De-)Embedder functionality.



Pin	Signal	Z = 75 Ω
1	Signal	
2	GND	

Figure 88: MN-Compact SDI IN/OUT Port BNC pinout

USO RESTRITTO

▼ DISPLAY Port

MN-Compact provides 2 DISPLAYPORT outputs for 3G/HD/SD-SDI Video signals. In MN-Compact- BASIC and -PLUS both DISPLAY Ports operate independently. In MN-Compact-PRO the DISPLAY Port 1/2 carries the same signals like the SDI Out port 3/4.

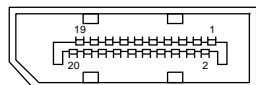

Pin	Signal	Pin	Signal
1	Lane0+	11	GND
2	GND	12	Lane3-
3	Lane0-	13	CONFIG1
4	Lane1+	14	CONFIG2
5	GND	15	AUX CH+
6	Lane1-	16	GND
7	Lane2+	17	AUX CH-
8	GND	18	Hot Plug
9	Lane2-	19	Return
10	Lane3+	20	DP_PWR

Figure 89: MN-Compact DISPLAYPORT pinout

▼ MADI Port

The MN-Compact-PRO provides 2 (BASIC/PLUS: 1) MADI Ports for single-mode or multi-mode SFP Transceiver. The original fiber module available from Riedel is highly recommended for use with the MADI Port as it provides the proper optical budget for other MADI devices. Each MADI Port supports up to 64 bidirectional Audio channels.

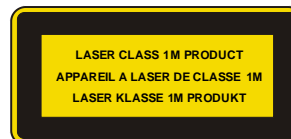
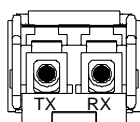
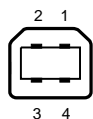

Figure 90: SFP (front view, top view)

▼ RockNet USB Port



Pin	Signal	Standard color
1	NC	red
2	RDM	white
3	RDP	green
4	GND	black

Figure 91: MN-Compact RockNet USB pinout

USO RESTRITTO

▼ RockNet LINK IN & LINK OUT Port

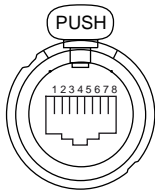

Pin	LINK IN	LINK OUT	Standard color
1	LNKI_TX0 +	LNKI_RX0 +	orange/white
2	LNKI_TX0 -	LNKI_RX0 -	orange
3	LNKI_RX0 +	LNKI_TX0 +	green/white
4	LNKI_TX1 +	LNKI_RX1 +	blue
5	LNKI_TX1 -	LNKI_RX1 -	blue/white
6	LNKI_RX0 -	LNKI_TX0 -	green
7	LNKI_RX1 +	LNKI_TX1 +	brown/white
8	LNKI_RX1 -	LNKI_TX1 -	brown

Figure 92: MN-Compact RockNet LINK IN/OUT Port RJ-45 pinout

▼ AES Port

The MN-Compact-PRO provides 4 (BASIC/PLUS: 2) AES connectors to connect Artist panels or AES signals to the MediorNet Frame.



Use an X-over cable between the Artist Card "CAT5-108 G2 RC" and the AES Port to connect an Artist-Mainframe at the MediorNet Frame.
Use a straight-through cable to connect an Artist-Panel at the AES Port.

For the ARTIST-Panel Ports the 2 channel mode is supported.

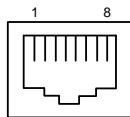

Pin	Signal	Z = 110 Ω
1	RxD+	
2	RxD-	
3	TxD+	
4	--	
5	--	
6	TxD-	
7	--	
8	--	

Figure 93: MN-Compact AES Port RJ45 pinout

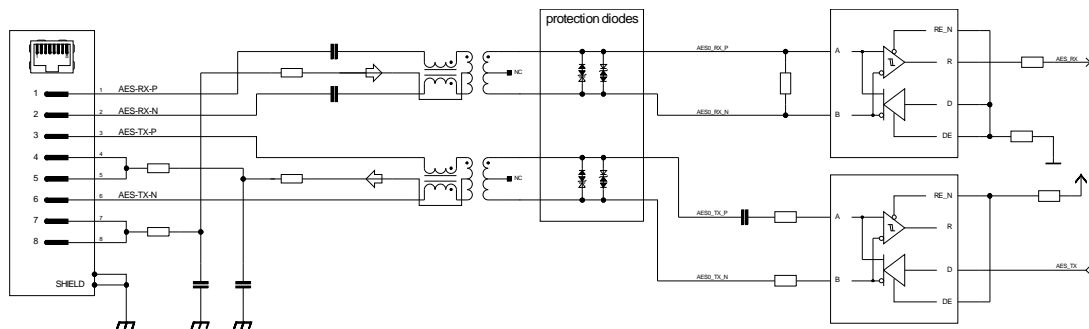

Figure 94: MN-Compact AES Port Schematic

USO RESTRITTO

▼ Analog IN & Analog OUT Port

MN-Compact-PRO provides 4 (BASIC/PLUS: 2) XLR in-/outputs for 4 analog Audio signals.

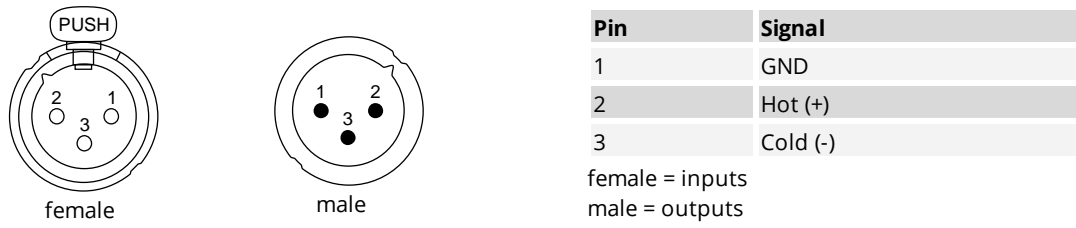

Figure 95: MN-Compact Analog IN/OUT Port XLR3 pinout

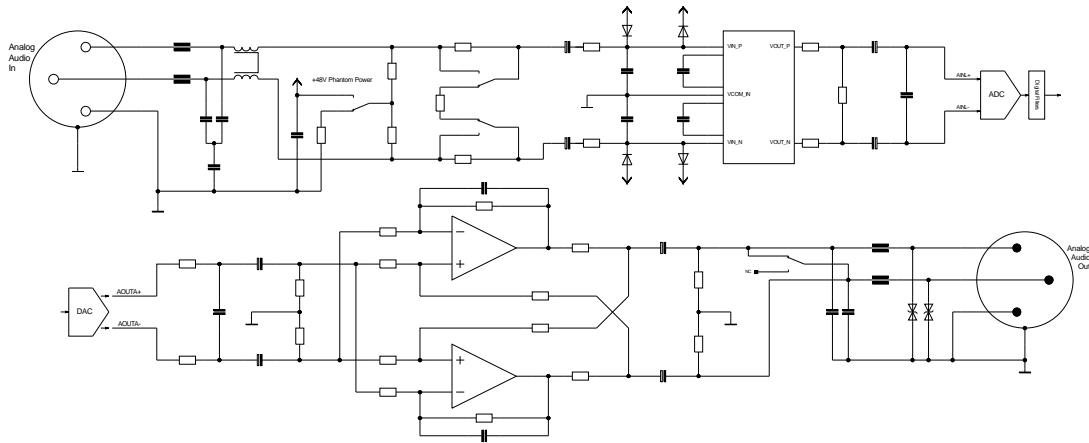
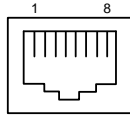

Figure 96: MN-MBP AIO Port Schematic

USO RESTRITO

▼ ETH Port

The MN-Compact-PRO provides 3 (BASIC/PLUS: 1) ETH connectors to tunnel electrical Ethernet over the MediorNet network. For a direct connection to a PC or to a network switch use any standard (straight-through) network patch cable. The MediorNet ETH Port is 1000Base-T compatible.



Pin	Signal	Standard color
1	BI_DA+	orange/white
2	BI_DA-	orange
3	BI_DB+	green/white
4	BI_DC+	blue
5	BI_DC-	blue/white
6	BI_DB-	green
7	BI_DD+	brown/white
8	BI_DD-	brown

Figure 97: MN-Compact ETH Port RJ-45 pinout

▼ SERIAL Port

MN-Compact-PRO provides 2 (BASIC/PLUS: 1) Serial Ports. Each Port can be individually configured to different formats (RS232 / 422 / 485). RS485 supports only 4-wire-mode.

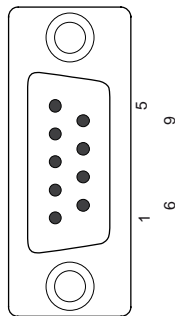

male

Pin	RS 232	RS 422	RS 485
1	Chassis	Chassis	Chassis
2	RxD	Rx +	Rx +
3	TxD	Tx -	Tx -
4	SG	SG	SG
5	SG	SG	SG
6	SG	SG	SG
7	SG	Rx -	Rx -
8	--	Tx +	Tx +
9	Chassis	Chassis	Chassis

Figure 98: MN-Compact Serial Port Sub-D-9 male pinout

USO RESTRITTO

▼ GPI Port

MN-Compact-PRO provides 1 Sub-D-25 connector with 10 GPI channels. Each single Channel can be individually set to an input or output.

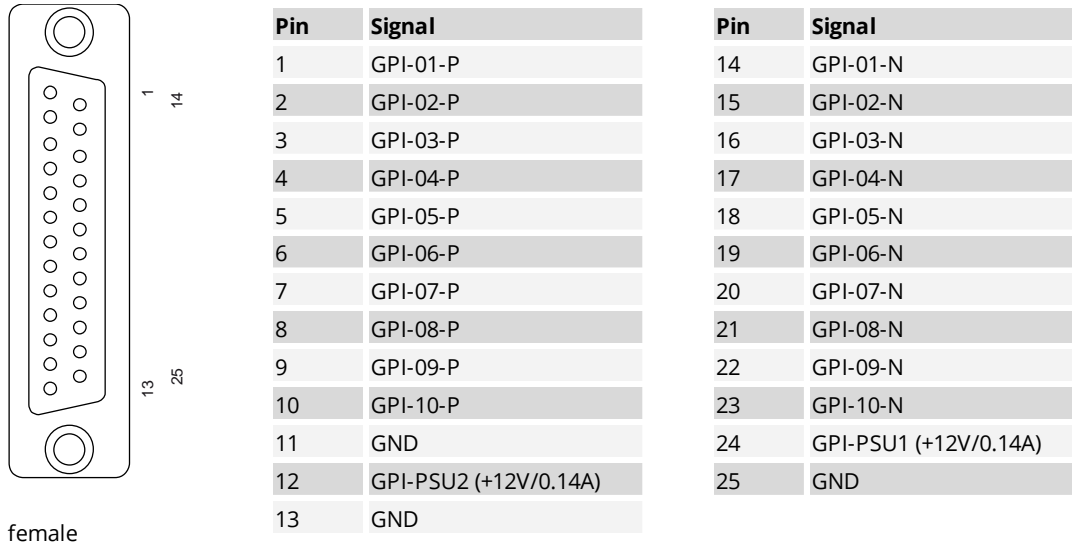

female

Figure 99: MN-Compact GPI Port Sub-D-25 female pinout

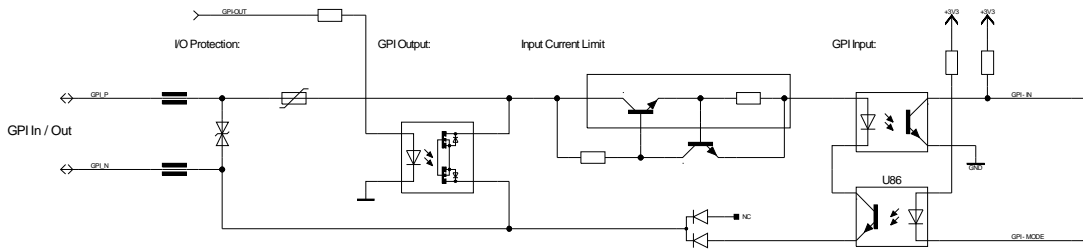

Figure 100: MN-Compact GPI Port Schematic

The input voltage range of the GPI Input is +5 .. +30 Vdc (5 .. 10 mA).

The maximum input voltage of the GPI Output is 30 Vdc (max. 100 mA).

USO RESTRITTO

3.2 MN-Compact-Fiber-Options

The Fiber-Options of MN-Compact are located at positions (F1 - F6) on the front side.
2 additional Fiber-Options are located at the positions (F7 - F8) at the rear side.



Figure 101: MN-Compact Fiber-Option F1-F6 (front side)



Figure 102: MN-Compact Fiber-Option F7-F8 (rear side)

MediorNet-Compact provides a maximum network bandwidth of 12 High-Speed Links.
Each High-Speed Link transport a gross bandwidth of 4.25Gbit/s.
A combination of different Fiber-Options is possible.

	<p>The replacement of Compact-Fiber-Options is done by Riedel or one of its authorized distributors or dealers and may under no circumstances be done by the user.</p>
---	--

Following Fiber-Options are available: (further Fiber-Options are available on request: CWDM, special Wavelengths, High-Power-SFPs, ...)

▼ 25G WDM Neutrik opticalCON QUAD

- 4 Fibers
- 6 WDM Wavelength multiplexed
- 6 bidirectional High-Speed Links = 6 x 4.25 GB

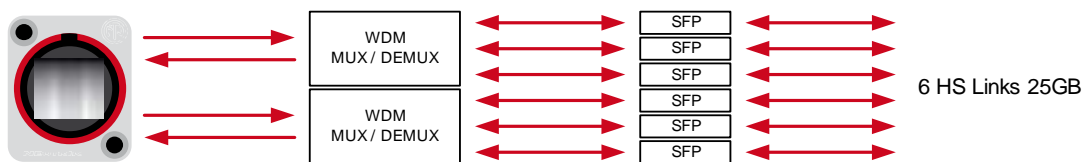

Figure 103: 25G WDM Neutrik opticalCON QUAD

USO RESTRITO

▼ 8.5G Neutrik opticalCON QUAD

4 Fibers

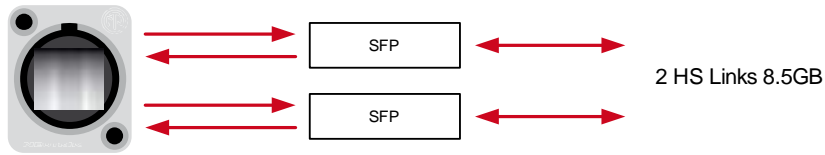

Figure 104: 8.5G Neutrik opticalCON QUAD

▼ 4.25G Neutrik opticalCON DUO

2 Fibers

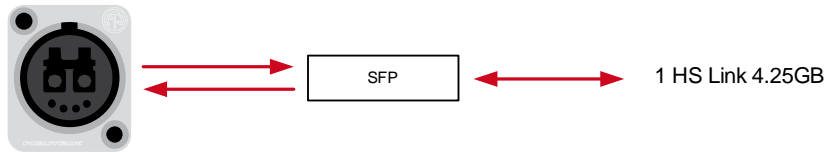

Figure 105: 4.25G Neutrik opticalCON DUO

▼ 8.5G Dual LC Duplex

4 Fibers

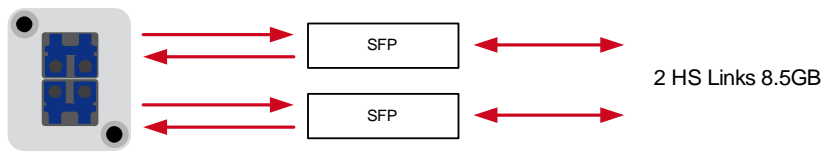

Figure 106: 8.5G Dual LC Duplex

▼ 4.25G Dual ST

2 Fibers

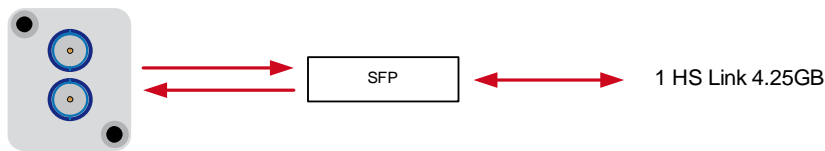

Figure 107: 4.25G Dual ST

USO RESTRITTO

3.3 MN-Compact-Option-Cards

The Option-Cards for the MediorNet-Compact can be inserted in following slot on the front side.



Figure 108: MN-Compact-PRO Option-Card Slot (front view)

	<p>The Compact-Option-Cards are replaceable by the user. The device must be disconnected from power before installing the Cards. Please notice that a firmware update is required after changing the Compact-Option-Card.</p>
---	--

Following Option-Cards are available:

MN-C-OPT-GV2	2x Grass Valley Interfaces
MN-C-OPT-SDI-8I	8x BNC Video inputs
MN-C-OPT-SDI-8O	8x BNC Video outputs
MN-C-OPT-SDI-4I4O	4x BNC Video inputs, 4x BNC Video outputs
MN-C-OPT-HDMI-4I	4x HDMI Video inputs
MN-C-OPT-HDMI-4O	4x HDMI Video outputs
MN-C-OPT-HDMI-2I2O	2x HDMI Video inputs, 2x HDMI Video outputs

3.3.1 MN-C-OPT-GV2

The MN-C-OPT-GV2 Option-Card provides two Neutrik opticalCON DUO connectors for the connection to Grass Valley Cameras or Grass Valley Base Stations. This Option-Card is equal to the MN-GV2 Card for the MediorNet-Modular.



Figure 109: MN-C-OPT-GV2 (front view)

USO RESTRITO

3.3.2 MN-C-OPT-SDI

The MN-C-OPT-SDI-xxxx Option-Card provides BNC inputs and outputs for Video signals.

This Card is available in three versions:

SDI-8I	8x BNC Video inputs
SDI-8O	8x BNC Video outputs
SDI-4I4O	4x BNC Video inputs, 4x BNC Video outputs

Common features:

- All Cards support 3G/HD/SD-SDI/ASI Video signals
- Video Test Pattern Generator

Input features:

- Auto Format Detection
- 16 Channel / 4 groups Audio De-embedding with Sample Rate Converter

Output features:

- Frame Synchronizer
- Video Delay (max. value depends on the input signal, see chapter: [Video Delay](#))
- Audio Delay for Embedder (up to 1 s in steps of 1 ms)
- 16 Channel / 4 groups Audio Embedding
- On Screen Display for Video outputs (Signal Info, Connection Status, Timecode)



This Option-Card is only available for the MediorNet-Compact-**PRO**.

▼ MN-C-OPT-SDI-8I

- 8x BNC Video inputs
- All inputs support 3G/HD/SD-SDI/ASI Video signals



Figure 110: MN-C-OPT-SDI-8I (front view)

USO RESTRITTO

▼ MN-C-OPT-SDI-80

- 8x BNC Video outputs
- Each output support HD/SD-SDI/ASI Video signals
- Port 5, 7, 9 and 11 support 3G Video signals
- Total support of max.
 4 3G Video signals or
 3 3G and 2 HD/SD-SDI/ASI Video signals or
 2 3G and 4 HD/SD-SDI/ASI Video signals or
 1 3G and 6 HD/SD-SDI/ASI Video signals or
 8 HD/SD-SDI/ASI Video signals



Figure 111: MN-C-OPT-SDI-80 (front view)

▼ MN-C-OPT-SDI-4I4O

- 4x BNC Video inputs
- 4x BNC Video outputs
- All inputs and outputs support 3G/HD/SD-SDI/ASI Video signals



Figure 112: MN-C-OPT-SDI-4I4O (front view)

USO RESTRITO

3.3.3 MN-C-OPT-HDMI

The MN-C-OPT-HDMI-xxxx Option-Card provides inputs and outputs for HDMI Video signals.

This Card is available in three versions:

HDMI-4I	4x HDMI 1.3a Video inputs
HDMI-4O	4x HDMI 1.3a Video outputs
HDMI-2I2O	2x HDMI 1.3a Video inputs, 2x HDMI 1.3a Video outputs

Common features:

- Neutrik D-Type HDMI socket
- All inputs and outputs support 3G/HD/SD-SDI/ASI Video signals
- Video Test Pattern Generator

Input features:

- Auto Format Detection
- 2 Channel Audio De-embedding with Sample Rate Converter

Output features:

- Frame Synchronizer
- Video Delay (max. value depends on the input signal, see chapter: [Video Delay](#))
- Audio Delay for Embedder (up to 1 s in steps of 1 ms)
- 8 Channel / 2 groups Audio Embedding
- On Screen Display for Video outputs (Signal Info, Connection Status, Timecode)



These Option-Cards are only available for the MediorNet-Compact-**PRO** and don't support HDCP.

▼ MN-C-OPT-HDMI-4I

- 4x HDMI 1.3a inputs



Figure 113: MN-C-OPT-HDMI-4I (front view)

▼ MN-C-OPT-HDMI-40

- 4x HDMI 1.3a outputs



Figure 114: MN-C-OPT-HDMI-40 (front view)

▼ MN-C-OPT-HDMI-2I2O

- 2x HDMI 1.3a inputs
- 2x HDMI 1.3a outputs



Figure 115: MN-C-OPT-HDMI-2I2O (front view)

USO RESTRITO

3.4 MN-Compact Status LEDs

The meaning of the Status LEDs of the MediorNet-Compact is listed in following table:

▼ MN-Compact-System

LED	POWER A/B	EXTERNAL DC
green	OK	OK
off	no power	no power

LED	DC FAULT (rear side)
red	error
off	no voltage / Voltage OK

LED	SYNC MASTER	FAN L/R
red	--	error
green	Frame is SYNC Master	OK
orange	Frame is SYNC Master and in "locking state" (attempt to synchronize to a Sync signal)	Fan cannot reach maximum rotation
off	Frame is SYNC Slave	--

	If the fan status LED is orange, ensure the dust filter is clean and the air flow through the ventilation opening on the left and right side of the Frame is not blocked.
---	---

▼ MN-Compact-LINK

LED	Link Status (left)	Link Activity (right)
red	physical link up, MediorNet link up SFP RX power too high/low	Connections present and interrupted
green	physical link up, MediorNet link up	Connections present and ok
orange	physical link up, MediorNet link down	--
off	physical link down, MediorNet link down	no Connections present

- Both LEDs are green for about 5 seconds while plugging an SFP
- Both LEDs are red if an incompatible SFP is plugged

▼ MN-Compact-RockNet

LED	Master	SYNC	COMM	48k	96k
red	--	--	MN <-> RN communication failure	48k Sample Rate mismatch	96k Sample Rate mismatch
green	Frame is RN SYNC Master	synchronization OK	MN <-> RN communication OK	48k Sample Rate active	96k Sample Rate active
orange	Frame is non-active RN SYNC Master	synchronization not OK	MN <-> RN communication interrupted	--	--
off	Frame is SYNC Slave	no synchronization	--	--	--

LED	USB	LINK IN	LINK OUT
green	PC connection established	connection OK	synchronization OK
orange	--	connection OK	synchronization not OK
off	no PC connection	no CAT.5 cable connected to neighbor device	

▼ MN-Compact-ANALOG IN/OUT

LED	ANALOG IN	48V
green	Audio input signal detected	--
orange	--	48V phantom power on
off	no Audio input signal detected	48V phantom power off

LED	ANALOG OUT	MUTE
red	--	Mute on
green	Audio output signal present	--
orange	Test tone active	--
off	no Audio output signal	Mute off

▼ MN-Compact-MADI

LED	SFP (left)	SFP (right)
red	--	SFP RX power too high/low (optical MADI only)
green	valid MADI signal output (at least 1 SubChannel)	valid MADI Input, signal locked
orange	Testsignals on all 64 SubChannels	--
off	no MADI signal output (MADI frame is still transmitted)	no valid MADI signal at the input

- Both LEDs are green for about 5 seconds while plugging an SFP

USO RESTRITTO

▼ **MN-Compact-AES**

LED	AES Input (left)	AES Output (right)
green	valid AES input signal	valid AES output signal
off	no valid AES input signal	no valid AES output signal

▼ **MN-Compact-SDI IN/OUT (MN-C-OPT-SDI / -HDMI / -GV2)**

LED	Video IN	Video OUT
red	invalid input Video format	invalid input Video format, no output
green	valid input Video format	valid Video signal
orange	test pattern active	test pattern active
off	no input signal	no output signal

▼ **MN-Compact-DISPLAYPORT OUT**

LED	Video output status
red	invalid input Video format, no output
green	valid output Video format
orange	test pattern active
off	no output signal

▼ **MN-Compact-SYNC IN/OUT**

LED	SYNC IN Status LED	SYNC OUT Status LED
red	Sync signal invalid / jitter to high	--
green	Connected SYNC signal is valid	SYNC OUT active
off	No SYNC signal at the input	SYNC OUT inactive

▼ **MN-Compact-ETH**

LED	ETH (left)	ETH (right)
red	--	MN connection present and interrupted
green	Ethernet Link Up	MN connection present and OK
off	no Ethernet Link Up present	no MN connection present

▼ **MN-Compact-CONFIG**

LED	CONFIG (left)	CONFIG (right)
green	Ethernet connection ok	--
orange	--	Port is enabled
off	no connection	Port is disabled (another port in the net is enabled)

▼ **MN-Compact-SERIAL, GPI**

no LED indication

USO RESTRITTO

4 General Information

4.1 Transport Latencies

Video Transport Delay

FSY On (System Synchronous)	Min. 150 μ s, Max. 1 Frame + 150 μ s (depending on input phase)	
FSY Off (System Synchronous)	500 μ s	
Sync to Source (Asynchronous)		

Digital Audio Transport Delay

without Sample Rate Converter	500 μ s	<i>(Standard Latency, independent of Network size and amount of Frames)</i>
with Sample Rate Converter	720 + 500 μ s: 1220 μ s	48 kHz sample rate
	360 + 500 μ s: 860 μ s	96 kHz sample rate

Analog Audio Transport Delay

Analog -> Digital conversion	646 + 500 μ s: 1146 μ s	48 kHz sample rate
	323 + 500 μ s: 823 μ s	96 kHz sample rate
Digital -> Analog conversion	500 + 625 μ s: 1125 μ s	48 kHz sample rate
	500 + 313 μ s: 813 μ s	96 kHz sample rate
Analog -> Digital -> Analog conversion	646 + 500 + 625 μ s: 1771 μ s	48 kHz sample rate
	323 + 500 + 313 μ s: 1136 μ s	96 kHz sample rate

Data Transport Delay

Serial Data	93.75 μ s + 10 μ s per MN hop + optical delay on long fibers	
GPI	93.75 μ s + 10 μ s per MN hop + optical delay on long fibers	
Ethernet	64 Byte packet size	60 μ s + 10 μ s per MN hop + optical delay on long fibers
	9000 Byte packet size	220 μ s + 10 μ s per MN hop + optical delay on long fibers

Grass Valley Video Transport Delay

Round-Trip-Delay	(Base Station --> Camera --> Base Station) 18 Video lines
------------------	---

USO RESTRITTO

4.2 Supported Formats

▼ Supported Video Formats

Format	Frame/Field Rates	Standard	Data Rate [Mbit/s]
525i	59.94	SMPTE 259M-C	270
625i	50	SMPTE 259M-C	270
720p	60 / 59.94 / 50 / 30 / 29.97 / 25 / 24 / 23.98	SMPTE 296M	1485
1080i	60 / 59.94 / 50	SMPTE 274M	1485
1080psF	30 / 29.97 / 25 / 24 / 23.98	SMPTE 274M	1485
1080p	30 / 29.97 / 25 / 24 / 23.98	SMPTE 274M	1485
1080p – A	60 / 59.94 / 50	SMPTE 425M Level A – mapping structure 1	2970
1080p – B-DL	60 / 59.94 / 50	SMPTE 425M Level B – Dual Link Mapping	2970
720p – B-DS	60 / 59.94 / 50 / 30 / 29.97 / 25 / 24 / 23.98	SMPTE 425M Level B – Dual Stream Mapping	2970
1080i – B-DS	60 / 59.94 / 50	SMPTE 425M Level B – Dual Stream Mapping	2970
1080p – B-DS	30 / 29.97 / 25 / 24 / 23.98	SMPTE 425M Level B – Dual Stream Mapping	2970
1080 psF – B-DS	30 / 29.97 / 25 / 24 / 23.98	SMPTE 425M Level B – Dual Stream Mapping	2970

Standards:

3 Gbps 3G-SDI SMPTE424M/425M Level A – mapping structure 1, SMPTE425M Level B

1.5 Gbps HD-SDI SMPTE292M

270 Mbps SD-SDI SMPTE259M, DVB-ASI SMPTE259M/EN50083

USO RESTRITTO

▼ Supported Synchronization Formats

Sync	Format	Sync	Format
Blackburst	NTSC	TriLevel	1080p30
Blackburst	PAL	TriLevel	1080p29.97
TriLevel	720p60	TriLevel	1080p25
TriLevel	720p59.94	TriLevel	1080p24
TriLevel	720p50	TriLevel	1080p23.98
TriLevel	720p30 (only at output)	TriLevel	1080psF24
TriLevel	720p29.97 (only at output)	TriLevel	1080psF23.98
TriLevel	720p25 (only at output)	WordClock	48 kHz
TriLevel	720p24 (only at output)	WordClock	96 kHz
TriLevel	720p23.98 (only at output)	WordClock	192 kHz
TriLevel	1080i60	WordClock Pulse	48 kHz
TriLevel	1080i59.94	WordClock Pulse	96 kHz
TriLevel	1080i50	WordClock Pulse	192 kHz

▼ Supported MN-GV2 Equipment

Cameras	LDK 8000
	LDK 8300 (single speed only)
	LDX 80 W
Basestations	LDK 4410
	LDK 4420
	LDK 4430
	LDK 4582
	LDK 4583

▼ Supported MN-ST-AL2 Equipment

Vista	5
	9
OnAir	3000

USO RESTRITO

4.3 Wiring

The MediorNet-Modular Frame can be deployed in two different ways: in-rack and front rack wiring. By default the 19" rack mount ears are mounted in that way. The front of the Frame is facing to the user, hence it provides fast and easy access during installation and changes. The 19" rack mount ears can be flipped 180° by the user. In this setup the front of the MediorNet Frame faces inside the rack and the wiring needs to be performed from the backside. This is useful for permanent installations and once installed it provides protection against accidental changes.

▼ Fiber Wiring

Each fiber link has an useable bandwidth of 3.2 Gbit/s. These 3.2 Gbit/s are divided into 512 timeslots, 6.1 Mbit each.

These segments can be filled with any kind of data such as Video, Audio, intercom and control.

	Different types of SFPs are used in the various MediorNet Cards. Hence, do not switch the SFPs from one Card to another!
--	--

SFP support

Fiber Port	Multi-Mode	Single-Mode
MN-LNK2/4, MN-ST-AL2	Yes	Yes
MN-LNK8/10/18 CWDM MUX Ports	No	Yes
MN-LNK8/10/18 CWDM ADD Ports (for external fiber signals)	No	Yes
Ethernet MN-ETH6	Yes	Yes
MADI MN-XSS, MN-MA2EO, MN-Compact	Yes	Yes

Each fiber Port must be connected to a fiber Port of the same type.

Fiber Port	Connection to
MN-LNK2 / MN-LNK4	MN-LNK2, MN-LNK4, MN-LNK8 ADD Port *, MN-LNK10 ADD Port *, MN-Compact Link 4.25G Dual ST / Neutrik opticalCON DUO, MN-Compact Link 8.5G Neutrik opticalCON QUAD / Dual LC Duplex, SmartRack MC-WDM ADD Port *, SmartRack MC-CWDM ADD Port *
MN-LNK8-CWDM MUX Port	MN-LNK8-CWDM MUX Port, MN-LNK18 CWDM ADD Port
MN-LNK10 CWDM MUX Port	MN-LNK10 CWDM MUX Port, MN-LNK18 CWDM ADD Port
MN-LNK18 CWDM MUX Port	MN-LNK18 CWDM MUX Port, SmartRack MC-CWDM MUX Port
MN-Compact Link 4.25G - Dual ST / - Neutrik opticalCON DUO	MN-LNK2, MN-LNK4, MN-LNK8 ADD Port *, MN-LNK10 ADD Port *, MN-Compact Link 4.25G Dual ST / Neutrik opticalCON DUO, MN-Compact Link 8.5G Neutrik opticalCON QUAD / Dual LC Duplex, SmartRack MC-WDM ADD Port *, SmartRack MC-CWDM ADD Port *
MN-Compact Link 8.5G - Neutrik opticalCON QUAD / - Dual LC Duplex	MN-LNK2, MN-LNK4, MN-LNK8 ADD Port *, MN-LNK10 ADD Port *, MN-Compact Link 4.25G Dual ST / Neutrik opticalCON DUO, MN-Compact Link 8.5G Neutrik opticalCON QUAD / Dual LC Duplex, SmartRack MC-WDM ADD Port *, SmartRack MC-CWDM ADD Port *
MN-Compact Link 25G - WDM Neutrik opticalCON QUAD	MN-Compact Link 25G WDM Neutrik opticalCON QUAD, SmartRack MC-WDM MUX Port *
SmartRack MC-WDM MUX Port	MN-Compact Link 25G WDM Neutrik opticalCON QUAD, SmartRack MC-WDM MUX Port *
SmartRack MC-CWDM MUX Port	SmartRack MC-CWDM MUX Port, MN-LNK18 MUX Port

* an SFP with matching wavelength is required at the corresponding LINK-Card

USO RESTRITO

The current fiber utilization of each single fiber can be observed by using the MediorWorks software.



MediorNet supports every known network topology and every combination of it.

▼ Maximum Cable Length

The MediorNet system supports the following maximum cable length:

Signal	Cable / SFP Type	Maximum length	min opt. Budget
AES Audio	Coax cable with BNC connectors	150 m	--
MADI Audio	Coax cable with BNC connectors	100 m	--
MADI Audio SFP *	MADI-MM-1310-155Mbit/s (62.5/125 ⁺ m) / (50/125 μ m)	2 km	11 / 7.5 dB
SD-Video	Coax cable with BNC connectors	180 m	--
HD-Video (720p 60 Hz)	Coax cable with BNC connectors	72 m	--
HD-Video (1080i 60 Hz)	Coax cable with BNC connectors	72 m	--
HD-Video (1080p 60 Hz)	Coax cable with BNC connectors	35 m	--
MN-MIO for MN-MBP	Cable with HDsub44 connectors	3 m	--
MN-LNK2/4 SFP *	MN-MM-850-4,25Gbit/S (62.5/125 ⁺ m) / (50/125 μ m)	70 m / 150 m	5 dB
MN-ST-AL2 SFP *	MN-SM-1310-4,25Gbit/s	10 km	9.6 dB
	MN-SM-HP-1310-4,25Gbit/s	40 km	18 dB
	MN-SM-1xyz-4,25Gbit/s	40 km	18 dB
MN-LNK8/10/18 CWDM SFP *	MN-SM-1xyz-4,25Gbit/s	40 km	18 dB
MN-ETH6 SFP *	ETH-SM-1310-1Gbit/s	20 km	15 dB
	ETH-RJ45-1Gbit/s	100 m	--
MN-GV2 SFP *	MN-Z-SFP-GV-LC-1310-9,6	10 km	9.6 dB

* Riedel recommended SFP Transceiver (separately available)

All cable lengths can vary with the number of connectors, patch fields and attenuation on the line.

USO RESTRITTO

4.4 MADi Format

Two different MADi formats are used for the transmission of streams with a Sample Rate of 96 kHz.

The Legacy-Format is used in RockNet-Products.

The Frame-Pattern is used in MediorNet-Products.

96 kHz Legacy-Format (RockNet-Products)

MADI Subframe	0	1	2	3	4	...	52	53	54	55	0
Audio Channel	Ch 1	Ch 1	Ch 2	Ch 2	Ch 3	...	Ch 27	Ch 27	Ch 28	Ch 28	Ch 1
Sample Number	n	n+1	n	n+1	n	...	n	n+1	n	n+1	n+2
AES3 Subframe	A	B	A	B	A	...	A	B	A	B	A

|----- 20.8 µs -----|

96 kHz Frame-Pattern (MediorNet-Products)

MADI Subframe	0	1	2	...	26	27	0	1	...	26	27	0
Audio Channel	Ch 1	Ch 2	Ch 3	...	Ch 27	Ch 28	Ch 1	Ch 2	...	Ch 27	Ch 28	Ch 1
Sample Number	n	n	n	...	n	n	n+1	n+1	...	n+1	n+1	n+2
AES3 Subframe	A	B	A	...	A	B	A	B	...	A	B	A

|----- 20.8 µs -----|

48 kHz (RockNet- / MediorNet-Products)

MADI Subframe	0	1	2	3	4	...	52	53	54	55	0
Audio Channel	Ch 1	Ch 2	Ch 3	Ch 4	Ch 5	...	Ch 53	Ch 54	Ch 55	Ch 56	Ch 1
Sample Number	n	n	n	n	n	...	n	n	n	n	n+1
AES3 Subframe	A	B	A	B	A	...	A	B	A	B	A

|----- 20.8 µs -----|

USO RESTRITTO

5 MediorWorks

Access, configuration and maintenance of the MediorNet system is handled by the Software MediorWorks based on Java. MediorWorks is independent of the PCs operating system. This means PCs with different operating systems can be used.

This Software was developed to offer the user easy and quick access to the system with a graphical interface. MediorWorks is intuitive to operate because it is similar to other GUI applications.

Multiuser

It is possible to attach one or more PCs simultaneously to the MediorNet system, to configure and maintain the system. The PC or a Network / Router can be connected directly to the Config-Port of the MediorNet Frame. All PCs are able to maintain and to configure the MediorNet Frames at the same time.

The configuration of the system is stored on a SD-Memory card in the MN-XSS of a Modular Frame and in the flash memory in the MN-Compact. The configuration can be stored on the configuration PC, too. This is useful for a quick configuration on other Frames.

5.1 What is required?

MediorWorks is a Java application. So it doesn't require a special operating system

Requirements for establishing a connection to the MediorNet system:

PC Workstation	Operating System	Windows XP (SP 3) Windows Vista (SP 2) Windows 7 (SP 1) Windows 8 and 8.1 Linux (tested on Ubuntu, Fedora and CentOS distributions) Mac OS X (= 10.8)
	Memory	Depending on the size of your MediorNet system at least 768MB free RAM are required.
	Oracle Java SE	Java Runtime Environment (JRE) Version 7 Update 51 or higher
	Browser	
		unused LAN-Port 100Base-T
	Ethernet Patch-cable (1:1)	

The communication between the MediorNet Frames and the MediorWorks Software is based on IP.



At least one MediorNet Frame must exist to configure the system.
An offline configuration is not possible in MediorWorks.

USO RESTRITTO

5.2 Start of the MediorNet frames

Connect the MediorNet PSU (Power Supply Unit) to mains. For redundancy reasons it is recommended that both power supplies of the Modular Frame are connected to separate AC power. Depending on the MediorNet version of the PSU, the connector is located at the front or rear. If MediorNet-Compact is used, it is recommended that the Frame is supplied by mains and an external 12Vdc power supply. The fans will start rotating full speed and the system will boot. During this time the color of the LEDs on the front panel will change periodically. After approximately 1 minute the booting of the system is completed, the LEDs change to a solid indication (no longer flashing) and the fans slow to a quiet, normal operation.

5.3 Download of MediorWorks

The MediorWorks application is stored on each MediorNet Frame and can be directly downloaded via Web browser from the MediorNet Frame.

In the default configuration the IP address of MediorNet Frames is configured within the private Zeroconf range. This address is assigned without the use of a DHCP server and is in the range between 169.254.1.1 and 169.254.254.254.

If the IP address of the Frame is unknown, download and execute MediorWorks from the [Riedel website](#) and use the feature [Frame Address Properties / MediorNet Finder](#) in the *System* menu to identify it.

Please configure the Network adapter of your PC with following address:

- Address 169.254.1.100
- Subnet mask 255.255.0.0

Or you can choose the automatically assigned address in the private IP range in the alternative configuration of the Network settings.

Connect your unused Network adapter with the Config-Plug of the MediorNet Frame.



Figure 116: Front view MN-XSS

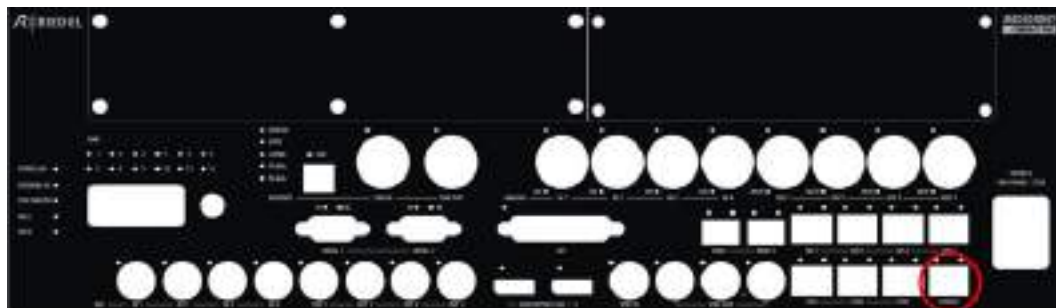



Figure 117: Front view MN-Compact

Enter the Zeroconf-Address 169.254.1.1 in the address field of your Browser.
 A HTML page will appear and offer you to download and start the MediorWorks application.

	The factory default IP address of a Frame in the Network is 169.254.1.1
---	--

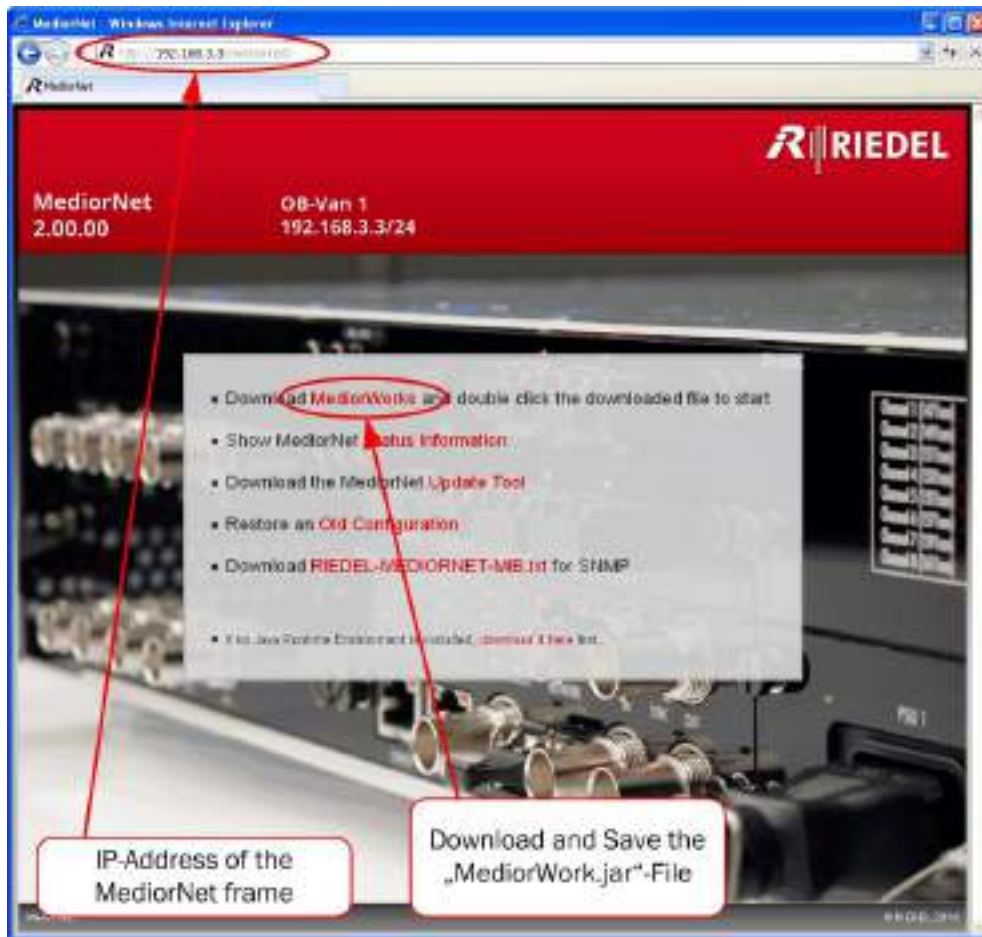

Figure 118: HTML website of MediorNet

The application can be stored on your local PC by a mouse-click on *Download MediorWorks*. Please take care that the extension of the filename is ".jar".

USO RESTRITTO

5.4 Start of MediorWorks

By double-click you can run the application on your PC. Please choose your network adapter, if required, which is connected to the MediorNet Frame.

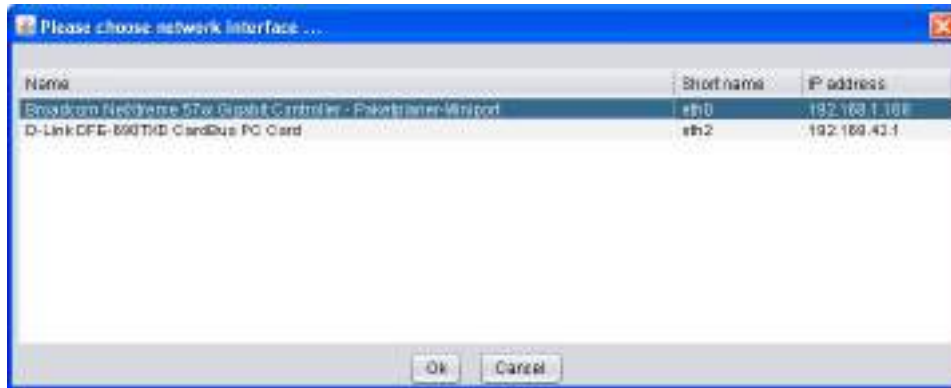

Figure 119: choose network interface

By default MediorWorks is starting with the CONNECTIONS view. On this Workspace you see two Windows. First the DEVICE BROWSER, second the CONNECTIONS-window. You find a short description in the chapters below.

More details of these windows can be found in the chapters [DEVICE BROWSER](#) and [CONNECTIONS](#).

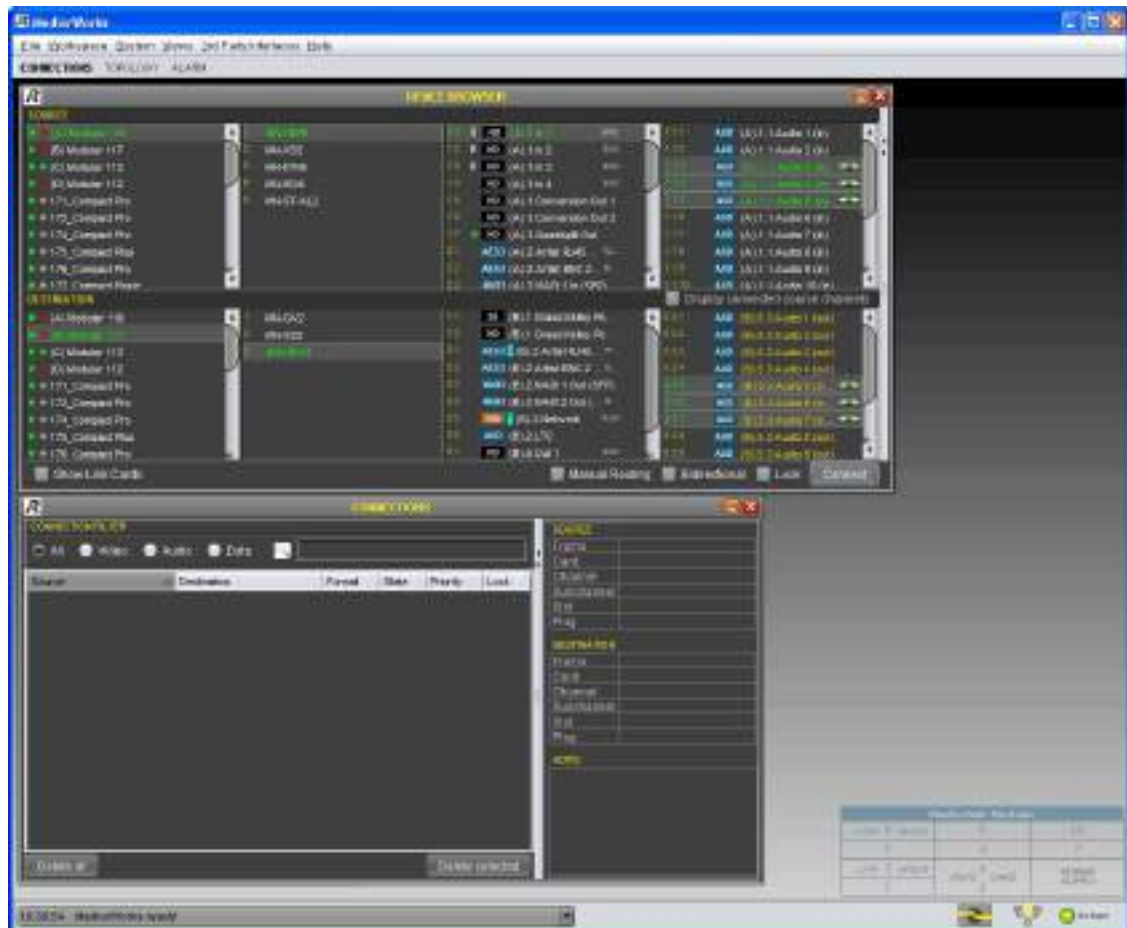



Figure 120: startup view of MediorWorks software

USO RESTRITO

 If the IP-addresses are unknown, you can identify the Frames with the tool "MediorNet-Finder" (see chapter [Frame Address Properties / MediorNet Finder](#)). In this tool you are also able to change the IP-addresses.

5.5 MediorWorks Structure

On the top is the menu bar. Every single menu item of MediorWorks is described in chapter [Menus of MediorWorks Software](#).



Figure 121: Menu bar (click to jump to the respective chapter)

Below the menus you see the present Workspaces. In every Workspace you find different windows for different functions. By default 3 different Workspaces (CONNECTIONS, TOPOLOGY and ALARMS) are present. By switching these Workspaces you can toggle between the different views. You are also able to setup more Workspaces with your desired windows. This topic is handled in chapter [Workspace](#).

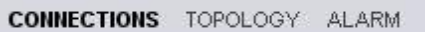

Figure 122: standard Workspaces (click to jump to the respective chapter)

In the bottom right corner of each Workspace is a table of the MediorNet Modular Frame slots displayed. Here the numbering of each slot (1 to 10) and the fixed positions of the Processing Card (MN-XSS) and the power supply. Also the positions of the two "Low-Speed-Slots" 3 and 8 is shown.

MediorNet Modular		
LOW 8 SPEED	9	10
5	6	7
LOW 3 SPEED	PROC. 4 CARD	POWER SUPPLY
1	2	

Figure 123: MediorNet modular slot table

The status bar is located on the bottom of the window.

On the left side are listed the last status messages of the system and the time of occurring. The latest message is on the top and always visible. Older messages can be displayed by left-click on the drop down symbol.

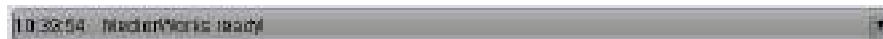

Figure 124: Status messages

Right beside the status messages is the enable/disable button of the "Unstable Link". If enabled and if a link is unstable, a popup-window with detailed information appears.



Figure 125: Unstable Link

USO RESTRITO

Right beside is the "Unstable Link" is the selection of the [Construction / Production - Mode](#).



Figure 126: CONSTRUCTION / PRODUCTION modes

On the right side is an icon, which is indicating the fault status of the system. A green symbol indicates an error free system and a red symbol indicates at least one error. The reason of the alarm can be investigated in the ALARMS Workspace.



Figure 127: Alarms (Events)



An [EVENTS-window](#) is opened by a mouse-click on this icon, if not already opened.

DEVICE BROWSER – window

The [DEVICE BROWSER](#) shows all Frames in the MediorNet network and all equipped Cards are displayed. This window as well as the [MATRIX](#) are the platform for the [creation of connections](#). The DEVICE BROWSER is divided in following regions:



Figure 128: DEVICE BROWSER - window

In the DEVICE BROWSER you find on the top the SOURCE and below the DESTINATION section. In the SOURCE section you are able to define your origin signal to be routed through the MediorNet network. In the DESTINATION section you can select the destination of the transported signal.

USO RESTRITO

The first column shows the locally connected Frame as well as all linked Frames in the MediorNet network. By a left-click a source and a destination Frame (Card/Channel/SubChannel) can be selected. The selection is indicated by green letters.

In the second column all Cards of the selected Frame are displayed.

In the third column you see the single channels of a selected Card. An icon informs about the type of signal of this Channel (**SD**, **HD**, **MADI**, **AES3**,...).

If a single Channel is selected, a further column is visible and the SubChannels of this Channel are displayed. An icon informs you again about the kind of signal.

	<p>In the SOURCE-region only Input-Cards and Input-channels are displayed. In the DESTINATION-region only Output-Cards and Output-channels are displayed. Bidirectional channels are displayed in both areas.</p>
---	---

The Filter feature is located right beside the DEVICE BROWSER.

Only the selected Channel types are displayed (all, Audio, Video and Data). This is very useful to simplify the handling of complex system setups and to find easily the required Channels.

A Split-Pane-Bar on the left side allows to change the proportion of the filter.



Figure 129: DEVICE BROWSER - Filter

More details of this window can be found in the chapter [DEVICE BROWSER](#).

USO RESTRITO

CONNECTIONS - window



Figure 130: Connections - window

In this window are all established connections displayed. To keep overview it possible to show only selected Signal types (all, Video, Audio and Data) by using the CONNECTIONS Filter. This filter can be combined with a text search. Only those kinds of connections are displayed which are including the search text in the source and/or destination name.

All shown connections can be sorted by Source, Destination, Format, State, Priority and Lock. The sorting is triggered by single- or double-click on the criteria in the headline.

If a row of a connection is marked, detailed information (Frame, Card, Channel, SubChannel, Slot and Plug) of this connection are displayed on the right side of the window. The field HOPS displays all MediorNet Frames, which are used for the data transfer.

More details of this window can be found in the chapter [CONNECTIONS](#).

USO RESTRITO

5.6 How to...

5.6.1 Renaming

By factory default the Name is generated out of the MediorNet Frames serial number. The name of the Frames, Cards and Channels, as well as every SubChannel, can be modified by double-click on it.

	<p>Names can be also changed easily by:</p> <ol style="list-style-type: none">1. selecting the desired Channel with the ARROW-keys on your keyboard2. Switch to the editor by pressing RETURN key (like double-click)3. modifying the text4. close editor by pressing the RETURN key again
---	---

It's also possible to rename by a right-click on the required name. A context menu is displayed. Select the last option "Configuration". In this CONFIGURATION-window it is also possible to change the naming.

The CONFIGURATION-window varies, depending on which Card or signal is selected. In the Frame configuration is an additional field to enter user notes.



Figure 131: CONFIGURATION - window of Frame

USO RESTRITTO

5.6.2 Configuration of Audio- / Video-formats

By right-click on the input- or output- Card and selecting the configuration option in the context menu, the CONFIGURATION-window is opened.



Figure 132: configuration of Video-formats

Input Card: (f.i. MN-HD4)



Figure 133: Input Card configuration

USO RESTRITTO

USO RESTRITO

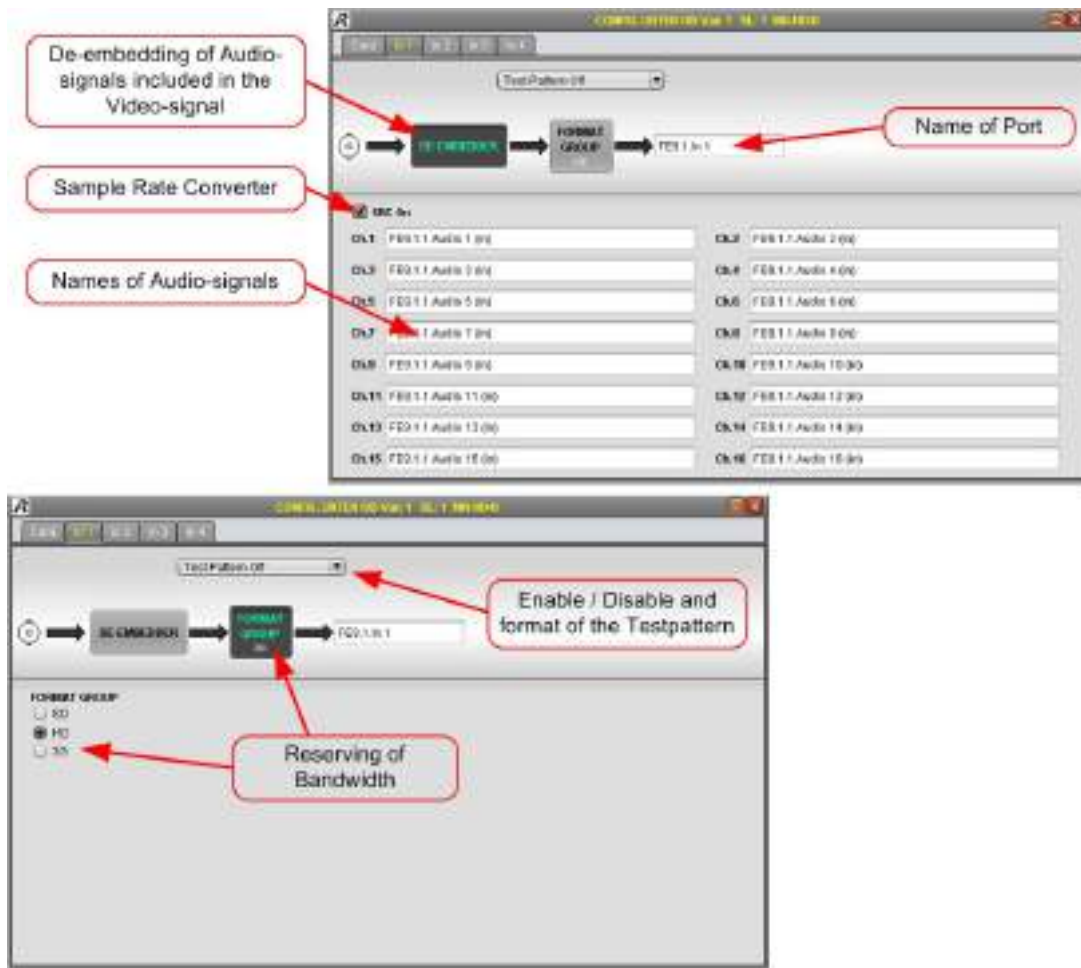

Figure 134: Input Channel configuration

The De-Embedder extracts the Audio SubChannels of a Video-signal to route them separately through the MediorNet network.

The Sample Rate Converter (SRC On) synchronizes asynchronous Audio signal to the MediorNet clock.

[Test Patterns](#) of any kind of type can be enable on all channels of Video input and output Cards.

Test Patterns (Test tones) are also available for Audio output Cards.

The signal type on an input Channel is detected automatically in the system. Due to the limited data rate of 4.25Gbit/s of the fiber links it is necessary to define and reserve the required data rate.

Output Card: (f.i. MN-HD40)

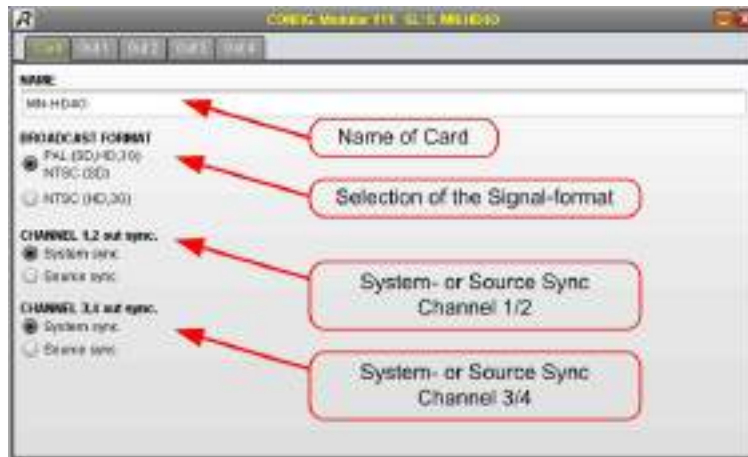

Figure 135: Output Card configuration

The output Card can be configured into PAL or NTSC mode.

To transmit a Video signal in its origin clock phase, the system needs to be set to "Source Sync". In this mode the next Channel is disabled and cannot be used. Only Channel 1 and 3 of the output Card can be set to "Source Sync" mode.

A Video signal is synchronized to the MediorNet system clock by setting the mode to "System Sync".

Several settings in the Out-tabs are grouped in function groups. A single group can be selected by a left-click on its symbol. In the function group *Frame Synchronizer* the actual picture at the output can be frozen by checking the *Manual Freeze* checkbox and the latency of this Channel can be set to fixed 500 μ s. In the Video delay region the phase of the signal can be adjusted between 1 pixel and 5 frames. The output picture in case of a signal loss can be switched between freeze (last valid picture) and gray/blue/black.

In the function group *Insert Text* the on-screen display with different information's and the [Timecode](#) can be overlaid in the Video signal. The size and position of the timecode can be also selected.

In the function group *Embedder* the groups of Audio SubChannels can be included in the Video-signal. The delay of the Audio signal can be set in 1ms steps up to 1000ms. Here you can also define the naming of the Audio channels.

The Video off checkbox in the *Video On/Off* group disabled the output of the Channel.

The Naming of the Video-Channel and the selection of [Test patterns](#) can be configured independent of the selected function group.

USO RESTRITTO

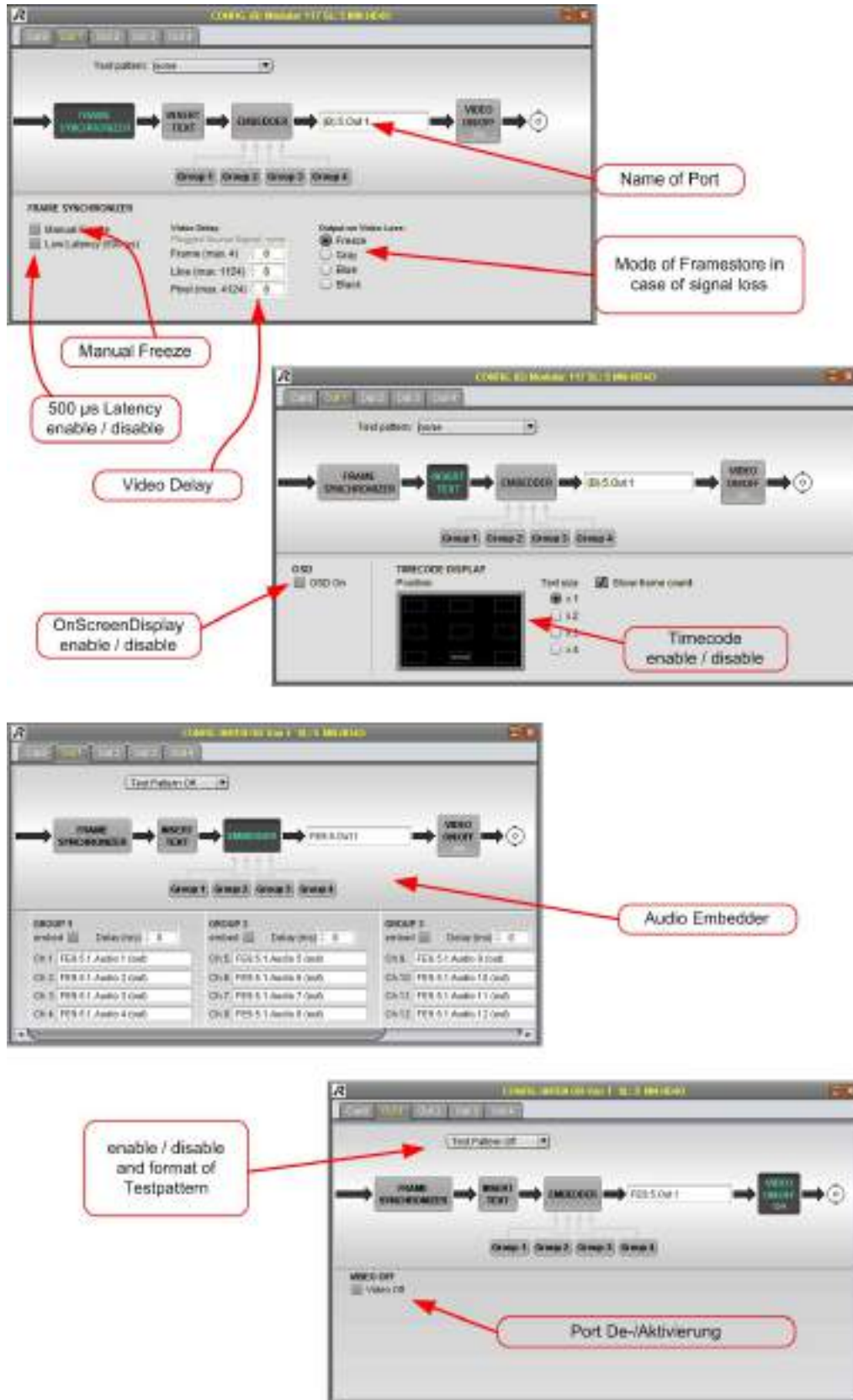

Figure 136: Output Channel configuration



5.6.3 Setup a Connection

To create a connection, you need to select in the source region a signal to be transmitted through the MediorNet network. First you select the respective Frame by a left-click. Selections are indicated by green letters. In the column right of the Frame you need to select the Card also by a left-click and the present Channels of this Card are displayed in a new column. Again you need to define a single Channel, which contains the signal to be transmitted.

If you select for instance a Video source, another column with AES mono Audio SubChannels are displayed. If you select for instance an AES3 Artist Channel on the MN-XSS Card, the A- and B- SubChannels of this AES signal are displayed. By selecting a MAD1 source, the user is able to access all 64 SubChannels. Every SubChannel can be routed individually.

In the destination region the user can define the signal target. The procedure of selecting is the same as selecting the source signal.

Connect-Button

By pressing the Button  with the mouse or CTRL-C on the keyboard, a connection is established and activated from the source Channel to the destination Channel. The connection is indicated by the icon  on the right side of the Channel name in the source and destination region, as well as in the CONNECTION-window.

The Connect button is only enabled if source and destination are compatible. Otherwise the button is disabled and it isn't possible to create a connection.

 If the checkbox "Display connected source channels" is enabled and an output Channel is involved in a connection, the name of the input Channel is displayed on the output Channel.



Figure 137: setup a connection

USO RESTRITTO

Drag & Drop

A further method to set up connections is to drag&drop the source signal on the destination signal. By releasing the mouse button the connection is established.



Figure 138: Drag & Drop

Multiple Connections

These two ways offering also the possibility to create multiple connections in only one step. For this select a continuous (with pressed *SHIFT*-key) or fragmented (with pressed *CTRL*-key) block of source channels and connect it to a single destination Channel or vice versa. The result is a connection pattern, that matches the selection of source channels.

This procedure works also vice versa. Hence, a multiple selection of destination channels can be assigned to a single source Channel.

Further it is possible to connect a certain amount of source channels with the same amount of destination channels. The rule is to connect either the same amount of source and destination channels or only one channels on the one side and multiple channels on the other side.

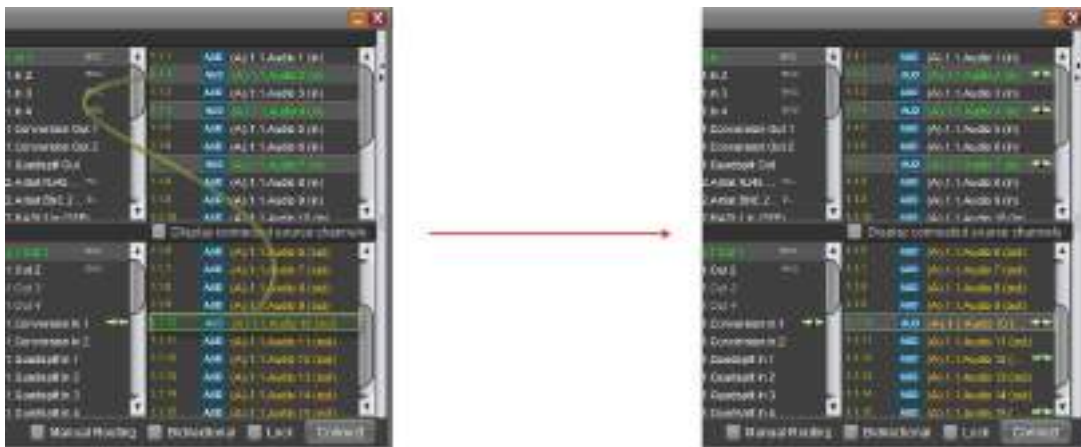

Figure 139: Connection by multi selection

USO RESTRITO

Matrix

A third way of routing is to set crosspoints in the [MATRIX](#). Before setting crosspoints in the matrix it is necessary to define user groups in the [GROUP EDITOR](#). Please refer to the respective chapters for the detailed description.



Figure 140: MATRIX

Repeat the steps to create all required connections.

For some transport signals, for example MAD1, it is possible to create a bidirectional connection. If required check the checkbox *BIDIRECTIONAL* before creating your connection. Otherwise the connection is established only from SOURCE towards DESTINATION.

If you have checked the checkbox *LOCKED* on the bottom of the *DEVICE BROWSER* before creating the connection, the connection is protected against a single click delete. If a connection is locked and you try to delete it, a window will pop up and ask for confirmation before the connection will be deleted. An already created connection can be protected in the *CONNECTIONS* windows by selecting the respective *LOCKED* checkbox.

For the routing you don't need to take care about the network topology. MediorNet detects all attached Frames automatically and calculates the shortest route.

Manual Routing

If you prefer to route your signal manually through the MediorNet network, enable the checkbox *MANUAL ROUTING* before creating your connection. In this case another column is displayed and let you include or exclude dedicated paths for the routing.

In the upper field *Include in route*: the user can include Frames, Cards and links to route. The routing is exactly performed in the order as they appear. If this is not feasible, the connection won't be established.

In the lower field *Exclude from route*: all items are displayed, which are excluded for the routing.

Both lists can be easily created by drag&drop.

The order of items in the include list can be changed by selecting and using the buttons *up* and *down* to move.

The selected entry can be deleted by pressing the *Del*-key on the keyboard. By right clicking an entry a context-menu opens and let you delete the selection or the complete list.

All items in the include- and exclude-list are deleted without confirmation by pressing the button *Clear both lists*.

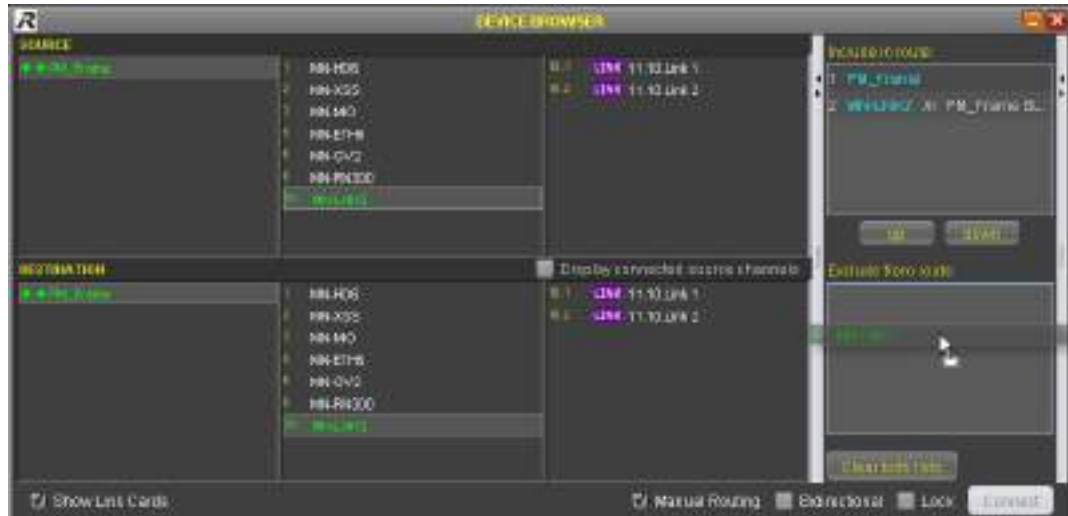

Figure 141: Manual Routing

USO RESTRITTO

5.6.4 Save a Configuration

The actual configuration can be stored on the PC by choosing the menu "File" and clicking on "Backup System Configuration". In the opening window the user can select the Frame, which configuration should be saved. You can select single Frames or all Frames by clicking the checkbox "Select all". In the comment area the user is able to note information about the configuration.



Figure 142: Save Frame Configuration

After applying a left-click on the Button "Save", a context menu is displayed and you can browse to the target path on your PC and enter a name for the configuration file.

The button "Save" will store all information about the configuration and routings.



Figure 143: Save the Configuration

USO RESTRITO

5.7 Features in Detail

5.7.1 Supported Cards

MediorWorks displays following Cards/devices supported by MediorNet:



MN-XSS	MediorNet Cross-Connect / Processing Card with Sync. option useable in slot: 2&4
MN-LNK2	Optical fiber LINK-Card 2x 4.25 Gbit/s, SFP useable in slot: 2xHigh-Speed 1, 5, 6, 7, 9 and 10
MN-LNK4	Optical fiber LINK-Card 4x 4.25 Gbit/s, SFP useable in slot: 4xHigh-Speed 7 and 10 (port 1+2 of this Card is not active, if used in 2xHigh-Speed Slot 1, 5, 6 or 9!)
MN-LNK8-CWDM	Optical fiber LINK-Card 4+4 ext x 4,25 Gbit/s incl. CWDM mux/demux useable in slot: 4xHigh-Speed 7 and 10
MN-LNK10-CWDM	Optical fiber LINK-Card 8+2 ext. x 4,25 Gbit/s incl. CWDM mux/demux useable in slot: 4xHigh-Speed 7&10
MN-LNK18-CWDM	Optical fiber LINK-Card 8+10 ext. x 4,25 Gbit/s incl. CWDM mux/demux useable in slot: 4xHigh-Speed 7&10
MN-HD4I	HD-SDI electrical Video input Card, 4x HD/2x 3G useable in slot: 2xHigh-Speed 1, 5, 6, 7, 9 and 10
MN-HD4O	HD-SDI electrical Video output Card, 4x HD/2x 3G useable in slot: 2xHigh-Speed 1, 5, 6, 7, 9 and 10
MN-HDO-4IO	HD-SDI optical Video in-/output Card, 4x 3G/HD useable in slot: 2xHigh-Speed 1, 5, 6, 7, 9 and 10
MN-HD6	HD-SDI electrical Video input and output Card, 2x HD/2x 3G input, 2x HD/2x 3G output, 2x HD input or output useable in slot: 2xHigh-Speed 1, 5, 6, 7, 9 and 10
MN-HDP6	HD-SDI electrical Video input and output Card, 2x HD/2x 3G input, 2x HD/2x 3G output, 2x HD input or output Quadsplit, 2x Conversion useable in slot: 2xHigh-Speed 1, 5, 6, 7, 9 and 10
MN-MA2EO	MADI Card BNC input/output, SFP input/output useable in slot: Low-Speed 3 and 8
MN-RN300	RockNet 300 Interface Card useable in slot: Low-Speed 3 and 8
MN-MIO (-E/-T)	Multi I/O Card, 8x AES, 8x AIO, 4x RS422, 12x GPI(I/O) (-E: electronic / -T: transformer) useable in slot: Low-Speed 3 and 8
MN-ETH6	6 Channel Ethernet Card useable in slot: 2xHigh-Speed 1, 5, 6, 7, 9 and 10
MN-GV2	2x HD/3G connection to Grass Valley Camera/Base Stations useable in slot: 2xHigh-Speed 1, 5, 6, 7, 9 and 10
MN-ST-AL2	Studer's A-Link-Card useable in slot: 2xHigh-Speed 1, 5, 6, 7, 9 and 10
MN-Compact	-BASIC / -PLUS / -PRO
MN-C-OPT-SDI	MN-Compact Option Card with BNC Video in-/output SDI-8I: 8x HD-SDI electrical Video input Card SDI-8O: 8x HD-SDI electrical Video output Card SDI-4I4O: 4+4x HD-SDI electrical Video in-/output Card
MN-C-OPT-HDMI	MN-Compact Option Card with HDMI Video in-/output HDMI-4I: 4x HDMI Video input Card HDMI-4O: 4x HDMI Video output Card HDMI-2I2O: 2+2x HDMI Video in-/output Card

USO RESTRITTO





5.7.2 Icons

This chapter explains all Icons used in the MediorWorks Software.







▼ Alarm Icons

	Information, for instance after creating a connection
	Warning, for instance the temperature of a Frame is rising
	Alarm, for instance the temperature of a Frame is too high

▼ General Icons

	Mute disabled
	Mute enabled
	1kHz test signal disabled
	1kHz test signal enabled







▼ Connections

	Connection is active, Signal is transmitted.
	Bidirectional connection active (for instance Artist Port, or link port).
	Connection is interrupted, for instance Card was unplugged, or fiber was removed.
	Bidirectional connection is interrupted.
	<p>Connection is damaged; parts of the allocation are failing. Difference to interruption: damaged connection can only be fixed by re-routing. This state occurs when:</p> <ol style="list-style-type: none"> 1. A connection is set up from Frame A via Frame B to Frame C. 2. If Frame C is removed from the network. 3. If the connection will be deleted on Frame A, the connection will be deleted on Frame A and B, but not on Frame C, due to C isn't attached any more. 4. If Frame C will be reconnected, the state is set to damaged. The connection is still configured on Frame C. <p>In this case the issue could be solved by performing a re-routing (if the bandwidth is sufficient).</p>
	bidirectional connection is damaged
	<p>SubChannels: If the ParentChannel is used in a connection. For instance if a MADI connection is used, all SubChannels are marked with the gray connection icon.</p> <p>ParentChannel: If minimum one SubChannel in a connection is used. I.e. if a MADI SubChannel connection is used, the MADI Channel is marked with the gray connection icon.</p> <p>Restriction: Output-Channels marked with this gray icon can <i>not</i> be used for new connections.</p>





▼ PSU Status

	PSU present and without failure
	Modular Frame: PSU defect or failing
	Compact Frame: PSU not active





▼ Audio Signals

	AES3 with 48kHz sampling rate (also for Artist port)
	AES3 with 96kHz sampling rate (also for Artist port)
	Mono with 48kHz sampling rate
	Mono with 96kHz sampling rate
	MADI with 48kHz sampling rate
	MADI with 96kHz sampling rate
	Studer's A-Link with 48kHz sampling rate

▼ Video Signals

	Standard Definition
	High Definition
	Full HD / 3G
	Asynchronous Serial Interface





▼ Data Signals

	General Purpose Interface Port
	Serial Port
	10 Mbit/s Ethernet
	100 Mbit/s Ethernet
	1000 Mbit/s Ethernet

▼ LINK Signals











	Fiber-Link
---	------------

▼ Connector, (Test) Signals

	A valid signal is connected to the Channel. >Valid< means in case of a Video signal, that the detected signal equals the configured signal. >Valid< means in case of an Audio signal, that a signal with a level of minimum -30dBFS is attached to the Channel (this is observed around every two seconds).
	Attached Video signal is not valid. That means that the detected signal is not matching the configured signal.
	Indicates a clipping above 0 dBFS in a Compact-Frame Audio Input.
	Valid test signal enabled.
	Invalid test signal (only visible on input ports). The selected test pattern requires more bandwidth than reserved.

USO RESTRITTO





▼ MATRIX

	Crosspoints without connection
	Incompatible crosspoint, for instance in the Audio matrix it's not possible to connect ports with 48kHz sampling rate to ports with 96kHz sampling rate.
	Connection is active, equal to 
	Connection is active and locked (can be set with the checkbox in the connections view or in the matrix). Locked connections can't be deleted directly. It's necessary to confirm it after a double-click or shift-left-click of the respective crosspoint in the popup window or to unlock them first in the context menu by right-click on the respective crosspoint.
	Connection interrupted, equal to 
	Connection interrupted and locked
	Connection damaged, equal to 
	Connection damaged and locked



▼ Unstable Link

	Unstable Link Warning enabled.
	Unstable Link Warning disabled.

▼ Construction-/Production-Mode Display









	Construction Mode. Automatic re-routing is not active.
	Production Mode. Automatic re-routing is active.
	Mode inconsistent. Some Frames are in Construction Mode and some are in Production Mode. The user needs to switch the Frame mode by clicking on the icon.
	Mode unknown. Occurs while starting MediorWorks until the Frames configuration is not read completely. After that the icon changes to the respective mode of the Frame.

▼ Status Display

	No new (not confirmed) Alarm or Information in the list.
	Minimum one new Alarm or Information in the list (flashing).

5.7.3 OSD On-Screen Display

The OSD feature displays status information's superimposed on the actual screen picture of the respective Channel and contains following information:

	No input signal present, no connection created
	Input signal present
	Input signal type invalid
	Test pattern enabled at the input / output
	Output signal active
	Input signal in "Freeze" state
	Connection ok
	Connection interrupted

If a converted Video stream is routed to an output with enabled OSD, the OSD shows the original format on the left side and the converted format on the right side. The name of the Video input Channel routed to the conversion input is also shown on the left side of the OSD



Figure 144: OSD of signal conversion

The On-Screen Display can be activated by right-click on the respective Channel and choosing the option *OSD On* in the context menu. This can be done in the *DEVICE BROWSER* as well as in the matrix.

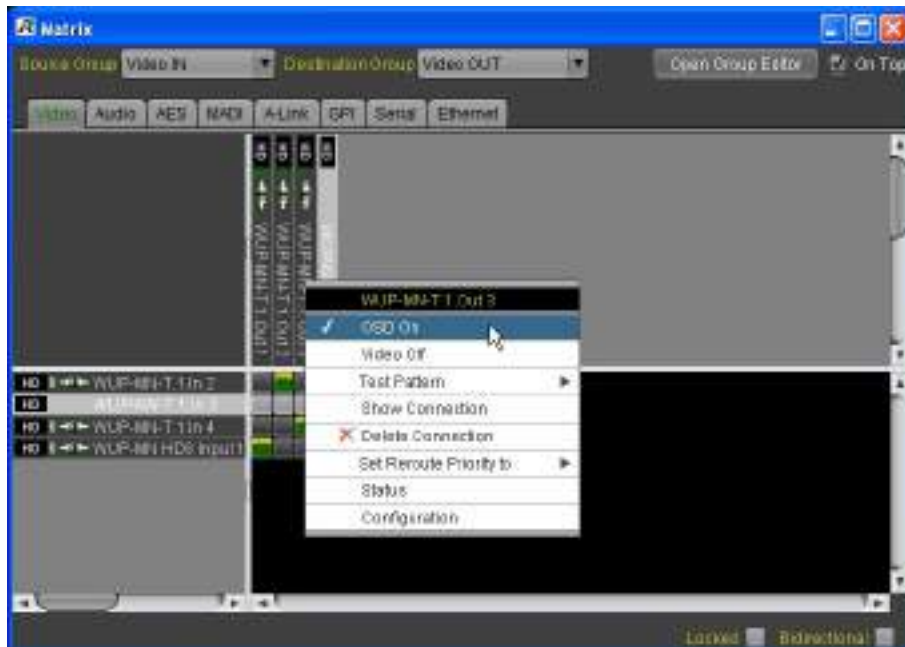

Figure 145: OSD On-Screen Display

USO RESTRITO

5.7.4 Construction / Production - Mode

A major feature of the MediorNet system is the automatic re-routing functionality. This feature will switch the signals, in case of loss of a fiber link, to a redundant path. This feature can be enabled in the Production Mode.

In the Construction Mode the system can be setup and configured to avoid unwanted switching and alarms in the system.

Construction Mode	Mode for setup and configuration of the system. Automatic re-routing is not activated .
Production Mode	Mode for production. Automatic re-routing is activated .



Figure 146: Construction / Production - Mode

A description of the used symbols modes can be found in chapter [Icons](#).

By left-click on this icon a context menu is opened and you can select between both modes. The option "Detail" will open a window with an overview of the states of all MediorNet Frames.

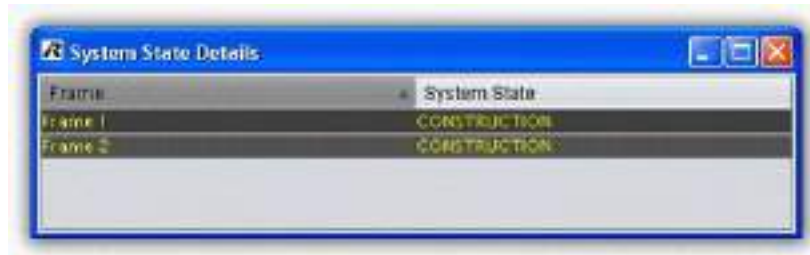

Figure 147: Construction / Production - Mode Detail

USO RESTRITO

5.7.5 Reroute Priority

If a link between two LINK-Cards is interrupted, the system will switch to a redundant link, if the system is set to production mode, to guarantee a signal transport from the source to the destination. A loss of a fiber link means also a loss of bandwidth. If there is not enough bandwidth to switch the signal transport to an alternative route, the need of a priority list is required. In this list is defined, which channels are important to route and which are minor and can be dropped. The rating is divided in 4 classes. The least important classification is *off*. That means the signal has no priority and won't be re-routed in case of fiber loss. The higher the re-route priority (1...3) the more important is the signal. Hence a signal with the priority 3 is handled preferred as a signal with the priority 1.

Existing uninterrupted links won't be aborted, independent of the priority list. I.e. an existing link without reroute priority (*off*) won't be aborted by an interrupted link with reroute priority 3.

The classification can be defined by a right-click on the respective destination Channel. Select the desired value in the option *Set Reroute Priority to* in the context menu. This is possible in the DEVICE BROWSER and in the CONNECTION-window, as well as in the MATRIX.



Figure 148: Re-routing Priority

The respective priority number is displayed in an icon with cyan background next to signal-format icon.

 The automated Re-routing is **only** enabled if Reroute Priorities are configured **and** if the system is in PRODUCTION Mode.

USO RESTRIKTIO

5.7.6 RockNet View

The RockNet View offers the possibility to configure RockNet devices via MediorWorks, which are connected to MN-RN300 Cards or MN-Compact devices. Please refer to the RockNet Manual for closer information about RockNet.

Device Support

Following RockNet devices are supported in the RockNet View:

RN.101.IO	RN.331.DD	RN.341.MY	MN-RN300
RN.102.IO	RN.332.DO	RN.343.VI	MN-Compact (-Plus/-Pro)
RN.141.MY	RN.333.DI	RN.351.FI	
RN.301.MI	RN.334.MD	RN.352.FO	
RN.302.LO	RN.335.DI	RN.362.IR	

Connection Establishment

The RockNet View is opened by right clicking on a RN-300 Card or on the RockNet elements of a MN-Compact (-Plus/-Pro) device and selecting the entry "RockNet View" in the context menu.



Figure 149: Open RockNet View

If the RockNet View is opened at a MN-RN300 Card for the first time, the IP address of the Card need to be entered.



Figure 150: Enter IP address (MN-RN300)

The IP address need to be configured in the RockWorks Software previously.

The IP address will be stored on the PC. The IP address needn't to be entered again in further connections. This process is not necessary when connecting to a MN-Compact.

USO RESTRITO

User Interface

The RockNet View consists of a splitted window:

On the left side is the Device-List.

In this region all RockNet devices are displayed, which are connected in the RockNet ring. By clicking on a device in this list, the respective device is shown in the Device View.

On the right side is the Device-View.

In this region device specific settings are done.

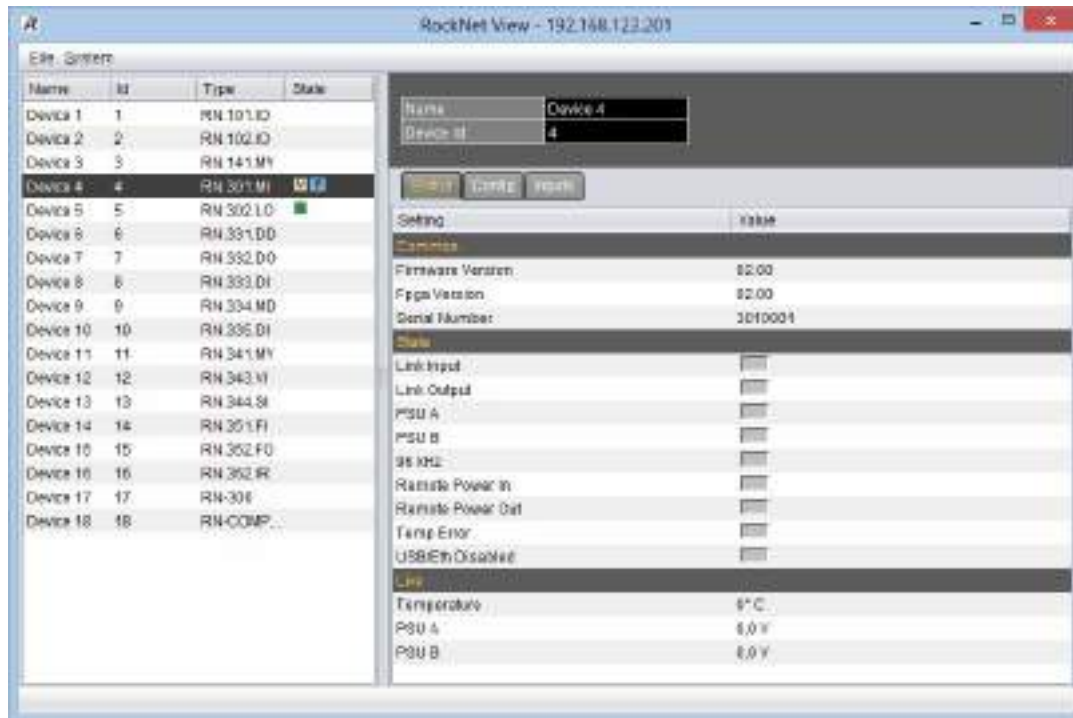

Figure 151: RockNet View User Interface

Device-List

The Device-List displays the Device-Name, the Device-ID, the device type and the status of the device.

	If a device without Device-Name is present, RockNet View will generate a temporary name like "Device n". This name is only displayed in the Software and will not be transmitted to the device.
--	---

The Device-Name and Device-ID can be modified in the Device-View.

The status bar indicates following conditions:

M	The device is configured as Master.
S	The device is configured as Secondary Master.
P	The device is connected to a PC.

If the status field is displayed with red background, a Channel collision persists (multiple in-/outputs of this device allocates the same Audio Channel).

USO RESTRITO

Device-View

In the Device-View all status information of single devices can be observed and all settings can be done. In the upper region of the Device-View the Device-Name and Device-ID is displayed. The content can be modified by clicking on the fields.

In the lower region contains the device settings, which are separated in multiple tabs. The number of values depends of the device type.

If a Channel-tab is selected, the button [Channel Wizard](#) is available in the upper region.



Figure 152: Device-View (upper region)

Status-Tab

On this tab device information are displayed, which can not be modified.

The screenshot shows the Status-Tab interface with a table of device settings. The table has two columns: 'Setting' and 'Value'. The settings are grouped into sections: General, I/O, and Link.

Setting	Value
General	
Firmware Version	02.00
FPGA Version	02.00
Serial Number	3140001
I/O	
Link Input	<input type="checkbox"/>
Link Output	<input type="checkbox"/>
PSU A	<input type="checkbox"/>
PSU B	<input type="checkbox"/>
36 kHz	<input type="checkbox"/>
Remote Power In	<input type="checkbox"/>
Remote Power Out	<input type="checkbox"/>
Temp Error	<input type="checkbox"/>
USB Ethernet	<input type="checkbox"/>
Link	
Temperature	0°C
PSU A	0.0V
PSU B	0.0V

Figure 153: Status-Tab

USO RESTRITTO

The information is splitted in 3 groups.

Common	
Firmware-Version	Version of the Firmware. The Firmware is programmed with the RockFlash-Software.
FPGA-Version	Version of the FPGA-Version of the device. It is also programmed with the RockFlash-Software.
Serial-Number	Serial Number of the device.

State	
Link Input	Indication, if the previous device in the ring is connected to the Link input.
Link Output	Indication, if the next device in the ring is connected to the Link output.
PSU A	Indication, if Power Supply A is connected.
PSU B	Indication, if Power Supply B is connected.
96kHz	Indication, if the device is to 96 kHz mode.
Remote Power In	Indication, if Remote Power is available at the Link Input.
Remote Power Out	Indication, if Remote Power is available at the Link Output.
Temp Error	Indication, if the device temperature is critical above 70° C.
USB/Eth Disabled	Indication, if the USB- and Ethernet-Ports are disabled for security reasons.
HA Remote	only MY-Cards: Indication, if the HA Remote cable is connected.
BNC Interface A/B	only MADI-devices: Indicates the BNC status of Interface A/B.
Fiber Interface A/B	only MADI-devices: Indicates the status of the optical input of Interface A/B.
SSL Interface A/B	only RN.334.MD: Indication, if a SSL-Signal is detected at Interface A/B.
Active SSL Interface	only RN.334.MD: Indicates the interface, which is actual active.
Lane A/B	only RN-300/MN-Compact devices: Indication, if MADI Lane A/B is connected.

Live	
Temperature	Displays the actual temperature of the device (°C).
PSU A/B	Displays the voltage of the power supply A/B (nominal +24V).

USO RESTRITTO

Config-Tab

On this tab device settings are displayed, which are not related to an in-/output Channel.

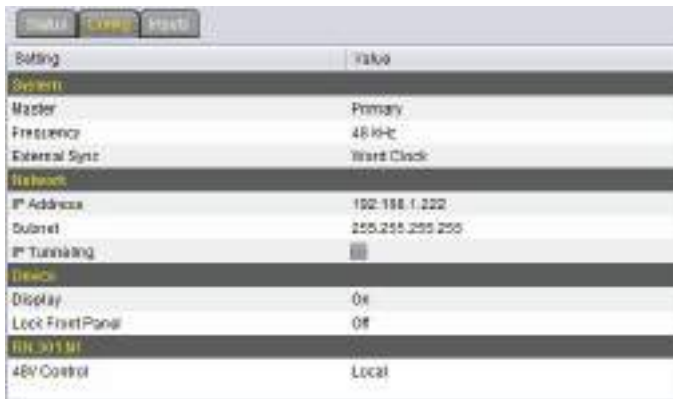

Setting	Value
System	
Master	Primary
Frequency	48 kHz
External Sync	Internal Clock
Network	
IP Address	192.168.1.222
Subnet	255.255.255.255
IP Tunneling	<input type="checkbox"/>
Device	
Display	Off
Lock Front Panel	Off
Other	
48V Control	Local

Figure 154: Config-Tab

System

Master	Selection, if the device is Master or Secondary Master of the RockNet ring. Only one Master can be defined (another Master would be disabled). IMPORTANT: a short Audio interruption may occur by changing this setting.
Frequency	A RockNet ring can be set to 48 kHz or 96 kHz mode, but not every device supports the 96 kHz mode. Hence, this setting is not always available.
External Sync	If a device is set to Master, the clock source can be selected here.

Network

IP Address	Entry of IP address to access the device via PC.
Subnet	Entry of Subnet-Mask of the IP address.
IP Tunneling	Enables the transmission of IP-Packets through the RockNet ring.

Device	
Enabled for RockNet View	This setting concerns devices with Presets. Presets are only supported by RockWorks. The "RockNet View" needs to be enabled for this device types.
Gain Type	Enabling of the Independent Gain feature.
Display	Switches the displays at the device on/off.
Lock Front Panel	Disable the operation on the front panel at the device.
Mode	only RN.334.MD: Enabling of the SSL mode.

Device specific settings	
Emul-Mode	only RN.131.MY/RN.341.MY: Enabling the Yamaha MY8 emulation.
Desk-ID	only RN.131.MY/RN.341.MY: Freely selectable number of the Yamaha-console. The same Desk-ID must be assigned, if multiple RN.141.MY/RN.341.MY-Cards are plugged in one Yamaha-console.
Slot-ID	only RN.131.MY/RN.341.MY: Number of the slot in the Yamaha-console, where the Card is plugged.
48V Control	only RN.301.MI: Defines, if the Phantom-Power can be controlled remotely via the Independent Gain feature or if the setting is done locally at the device.
Channels	only RN.334.MD: Activates the 56 Channel mode (only Drops).
Priority	only RN.334.MD: Defines the preferred Channel, if the optical and electrical input are active.
Mode	only RN.343.VI: The Card is able to work in Soundcraft or Studer mode.
Adds/Drops	only RN.344.SI: The number of channels, which are routed from RockNet in the console.

USO RESTRITTO

Channel-Tab

The number of Channel-Tabs depends of the device type, especially of the number and type of interfaces.

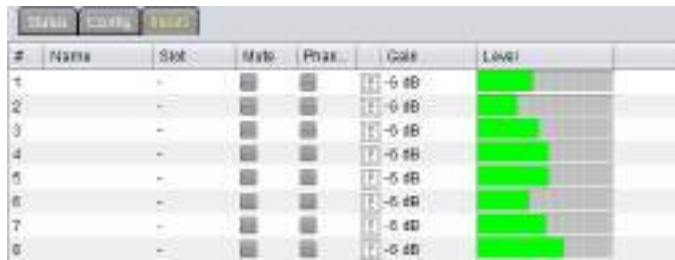

#	Name	Slot	Mute	Phant.	Gain	Level
1					-5 dB	
2					-5 dB	
3					-5 dB	
4					-5 dB	
5					-5 dB	
6					-5 dB	
7					-5 dB	
8					-5 dB	

Figure 155: Channel-Tab

#	Number of channels.
Name	Channel-Name (up to 12 characters).
Slot	Assignment of 1 out of 160 RockNet channels. Only one Channel can be routed to one single input (Add), but to multiple outputs (Drops).
Mute	Mutes the input signal.
Phantom	Enables/Disables the 48V voltage of one input channel.
Gain	Sets the Gain value of one Channel. This can be done by direct entering the numeric value or by a Fader, which appears by clicking on the Fader-Button. Changing the Gain value of an output Channel is only possible, if the Gain type of the respective device is set to "Gain Master" or "Gain Slave".
Level	Displays the actual Audio level of the Channel. A red bar is displayed at the end of the bar for several seconds, if the Audio signal is clipping.
Clip	Sets the Clip-Level (only available for analog output devices).
SRT	only RN.335.DI: Enables/disables the Sample Rate Converter.

Channel Wizard

The Channel Wizard is a dialog window to configure a range of in-/output channels.



Figure 156: Channel Wizard

The fields "First Input" and "Last Output" defining the range of the channels of the device.

Check the box "First Channel" and select the first Channel of the 160 RockNet channels, to route the selected range to the RockNet channels.

It is also possible to assign Channel-Names automatically, if the box "Name" is checked and a Name and Start Number is entered.

For example if "Ch " is set as Name and "1" is set as Start Number, the system will generate the Channel-Names "Ch 1", "Ch 2" and so on.

USO RESTRITO

5.7.7 CONFIGURATION - window

By right-click on a Frame, Card, Channel or SubChannel a context menu opens. The option "Configuration" will open the same named window. It can be opened in the [DEVICE BROWSER](#) as well as in the [MATRIX](#). Depending on clicking on a Frame, Card Channel or SubChannel, different contents are displayed in the CONFIGURATION-window described in the following chapters.

Entries and changes in text fields in the CONFIGURATION-windows are automatically applied, if the user:

- click on a button, on a checkbox, in another text field
- press the tab key (the focus moves to the next field, button or checkbox)
- clicks in a "free region" outside the CONFIGURATION-window
- close the CONFIGURATION-window
- close MediorWorks

The Enter key is not required to apply the entries.

CONFIGURATION windows are automatically re-opened, if they were open while closing MediorWorks.

USO RESTRITO

5.7.7.1 MN-Modular Frame CONFIGURATION

In the headline are the type and name of the Frame shown.



Figure 157: Frame CONFIGURATION

The meanings of the different fields are described in the table below:

Frame Long Name	Detailed name of the Frame.
Frame Short Name	Short name of the Frame. This is also the default prefix for the Channel names.
Apply Short Name	Apply the entered short name.
System Location	Location information
System Contact	Contact information (f.i. in case of trouble)
LED Brightness	The brightness of the status LEDs of the Frame can be adjusted between 0% - 100% (exceptions are the Fan and PSU)
User Notes	empty field for the user to enter any notes

	The brightness can be changed either by up & down arrow-cursor-keys or by the mouse-wheel: Mouse-wheel or arrow-cursor key only: 1 step, with pressed <i>ALT</i> -key: 5 steps, with pressed <i>SHIFT</i> -key: 10 steps.
---	--

USO RESTRITTO

5.7.7.2 MN-XSS CONFIGURATION

In the headline is the name of the Frame, the name of the MN-XSS as well as the slot shown.

▼ MN-XSS Card CONFIGURATION

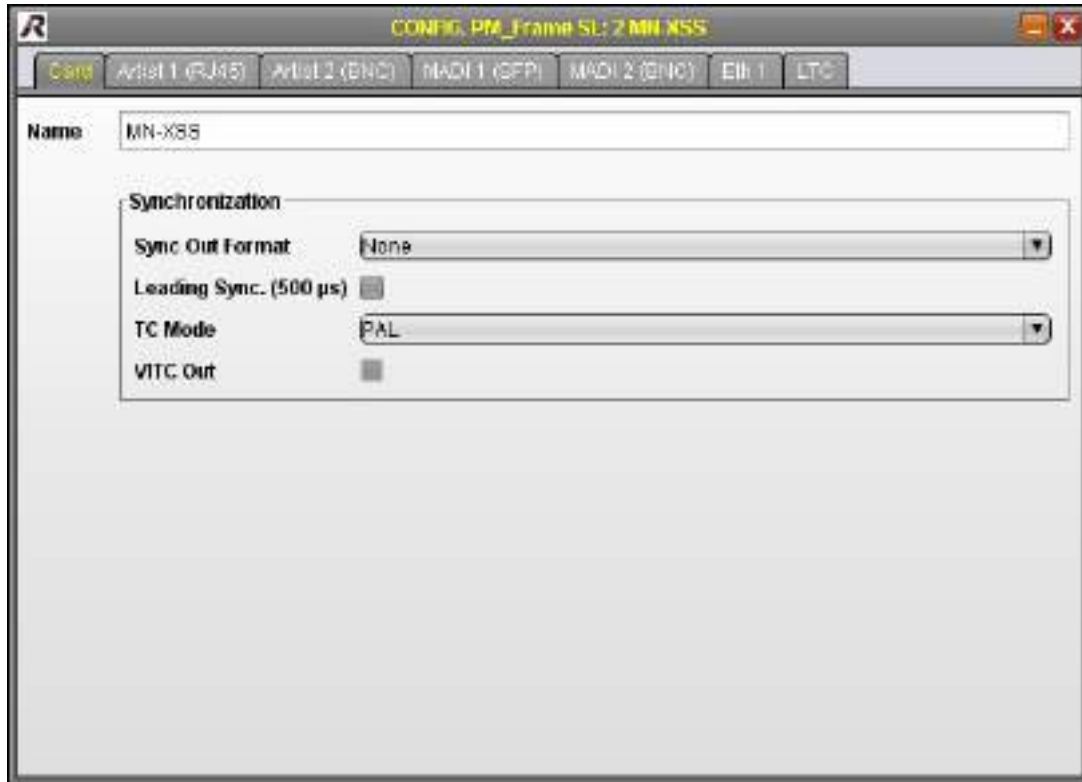

Figure 158: MN-XSS Card CONFIGURATION

The meanings of the different fields are described in the table below:

Name	Name of the Card
Sync. Out Format	Definition of the signal format of the Sync Out port on the MN-XSS see chapter Supported synchronization formats .
Leading Sync.	By checking this checkbox the Sync signal at the SYNC OUT port of this Frame is generated 500µs before the MediorNet wide sync signal
TC Mode	Selection of Timecode format (PAL/NTSC/NTSC DF).
VITC Out ¹	By checking this checkbox the MediorNet Timecode is embedded in the Sync-Signal.

¹ This checkbox is only available, if the parameter **Sync. Out** is set to *Blackburst PAL* or *Blackburst NTSC*.

The synchronization settings can be set also in the windows [Frame Synchronization](#).

▼ MN-XSS Artist CONFIGURATION

The contents in the tab *Artist 1 (RJ45)* and *Artist 2 (BNC)* are identical.



Figure 159: MN-XSS Artist CONFIGURATION

The left part of this window contains input settings concerning *Artist In*. These are:

Name	Name of the input
Mode	Panels or Artist synchronized to MediorNet Artist asynchronous to MediorNet Audio AES3
Sample Rate	48kHz / 96kHz
Mono Channel Left Name	Name of left mono Channel
Mono Channel Right Name	Name of right mono Channel

The right part of this window contains output settings concerning *Artist Out*. These are:

Name	Name of the output
Mute	Enable/disable of output signal (or mono Channel)
Test Signal	Enable / disable of the 1kHz test signals (or mono Channel)

USO RESTRITTO

▼ MN-XSS MADI CONFIGURATION

The contents in the tab *MADI 1 (SFP)* and *MADI 2 (BNC)* are identical.



Figure 160: MN-XSS MADI CONFIGURATION

The meanings of the different fields are described in the table below:

Sample Rate	Selection of the sample rate (48/96 kHz)
Mono Out Channels	Selection of the number of MADI channels: 64/56/56+1 in 48kHz sample rate mode 32/28/28+1 in 96kHz sample rate mode
MADI In SRC On	Enabling the sample rate converter (only MADI 1 and 48 kHz)
(Left) Input MADI / Mono Channel Name	Name of the MADI-Inputs / Mono-channels
(Right) Output MADI / Mono Channel Name	Name of MADI-Outputs / Mono-channels

On the right of the output name is the symbol for the 1kHz test signal and the muting. A left-click on these icons will enable/disable the function.

USO RESTRITO

▼ MN-XSS Ethernet CONFIGURATION



Figure 161: MN-XSS Ethernet CONFIGURATION

Via the "Network" Port on the MN-XSS Card can be tunneled additional 1000BaseT Ethernet Packets via the fiber. The meanings of the different fields are described in the table below:

Name	Name of the Output
Bandwidth	Reservation of bandwidth used for the Ethernet-Tunnel

USO RESTRITTO

▼ MN-XSS LTC CONFIGURATION

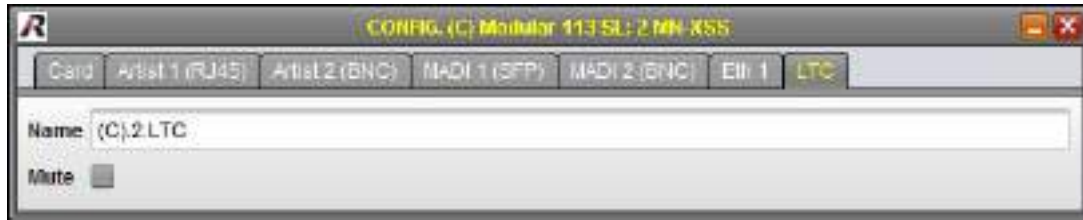

Figure 162: MN-XSS LTC CONFIGURATION

The meanings of the different fields are described in the table below:

Name	Name of the LTC input
Mute	Enabled muting will disconnect the external LTC at the Audio input and the LTC Channel. In this case the timecode is no longer available for the system.

USO RESTRITTO

5.7.7.3 MN-HD4I CONFIGURATION

In the headline is the name of the Frame, the name of the MN-HD4I as well as the slot shown.

▼ MN-HD4I Card CONFIGURATION



Figure 163: MN-HD4I Card CONFIGURATION

In this field the name of the Card can be entered or changed.

USO RESTRITO

▼ MN-HD4I In CONFIGURATION

The contents of the tabs *In 1* to *In 4* have the same structure.

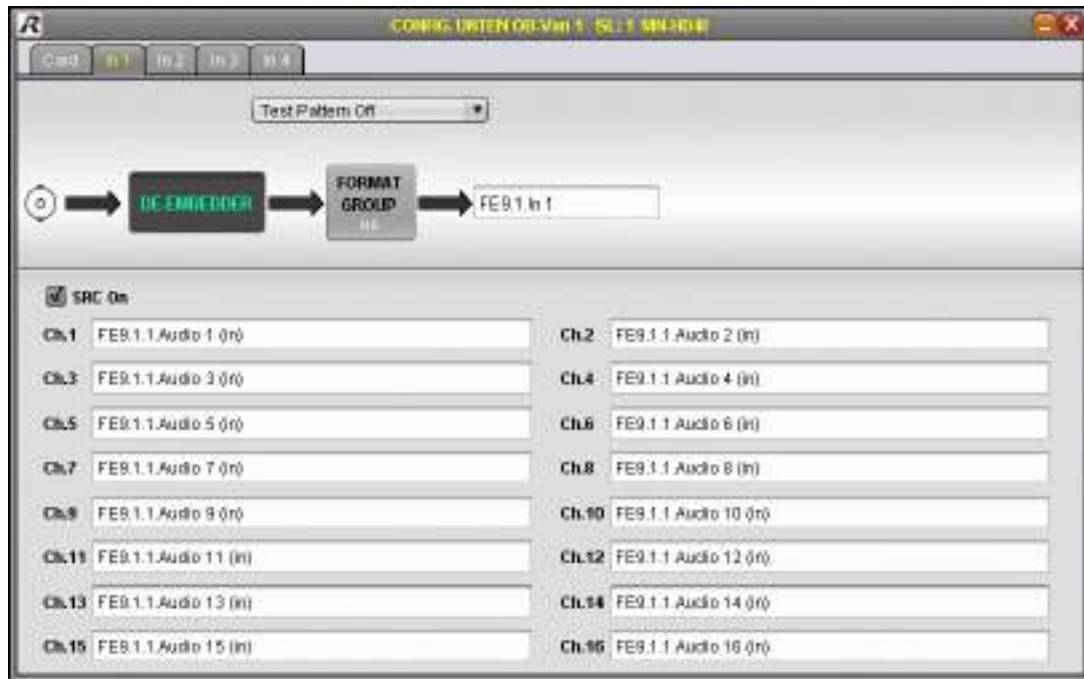

Figure 164: MN-HD4I In CONFIGURATION

The meanings of the different fields are described in the table below:

Test Pattern	Enable / disable and format selection of the test pattern (see chapter Test Pattern).
	Excluding of the 16 Audio SubChannels (see chapter De-Embedder / Embedder).
	Determination of required bandwidth of respective Channel (see chapter Format Group). 3G is only on Channel 1 and 2 available (see chapter Supported Formats).
Name	Name of the Channel (here FE9.1 In 1)

USO RESTRITTO

5.7.7.4 MN-HD40 CONFIGURATION

In the headline is the name of the Frame, the name of the MN-HD40 as well as the slot shown.

▼ MN-HD-40 Card CONFIGURATION

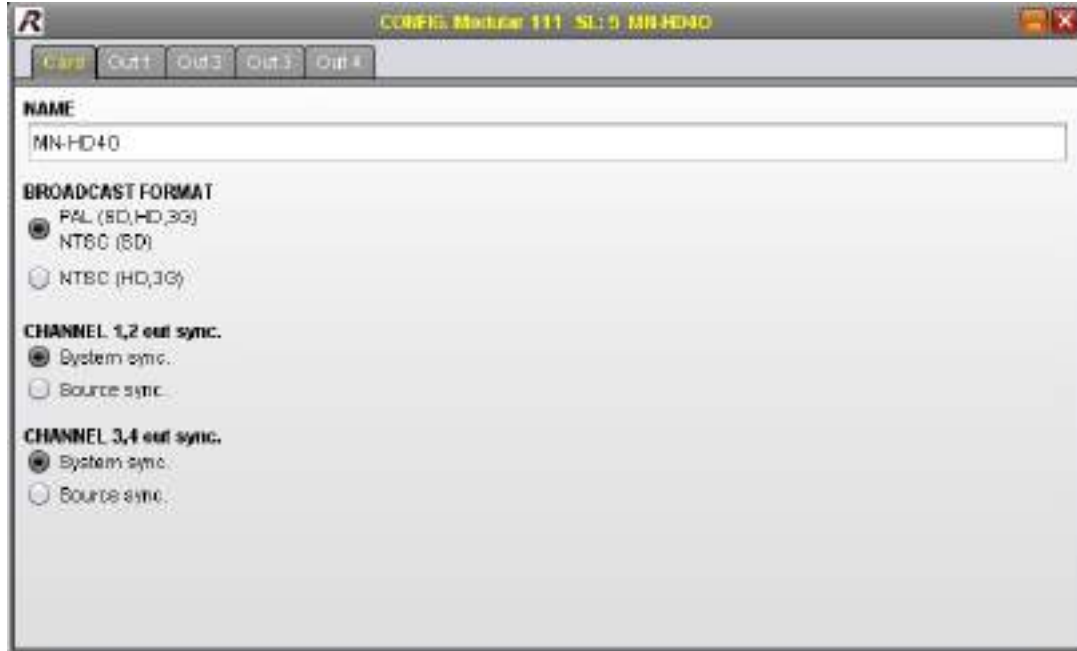

Figure 165: MN-HD40 Card CONFIGURATION

The meanings of the different fields are described in the table below:

Name	Name of the Card
Broadcast Format	Selection of the output signal format (PAL, NTSC) depending on the input signal. No format conversion is performed. See chapter Supported Formats .
Channel 1,2 out sync	<p>System sync: Video signal at output is synchronized to the system clock.</p> <p>Source sync: Video signal at output 1 keeps the same phase of the input signal. Output 2 disabled.</p>
Channel 3,4 out sync	<p>System sync: Video signal at output is synchronized to the system clock.</p> <p>Source sync: Video signal at output 3 keeps the same phase of the input signal. Output 4 disabled.</p>

USO RESTRITO

▼ MN-HD-40 Out CONFIGURATION

The contents of the tabs *Out 1* to *Out 4* have the same structure.

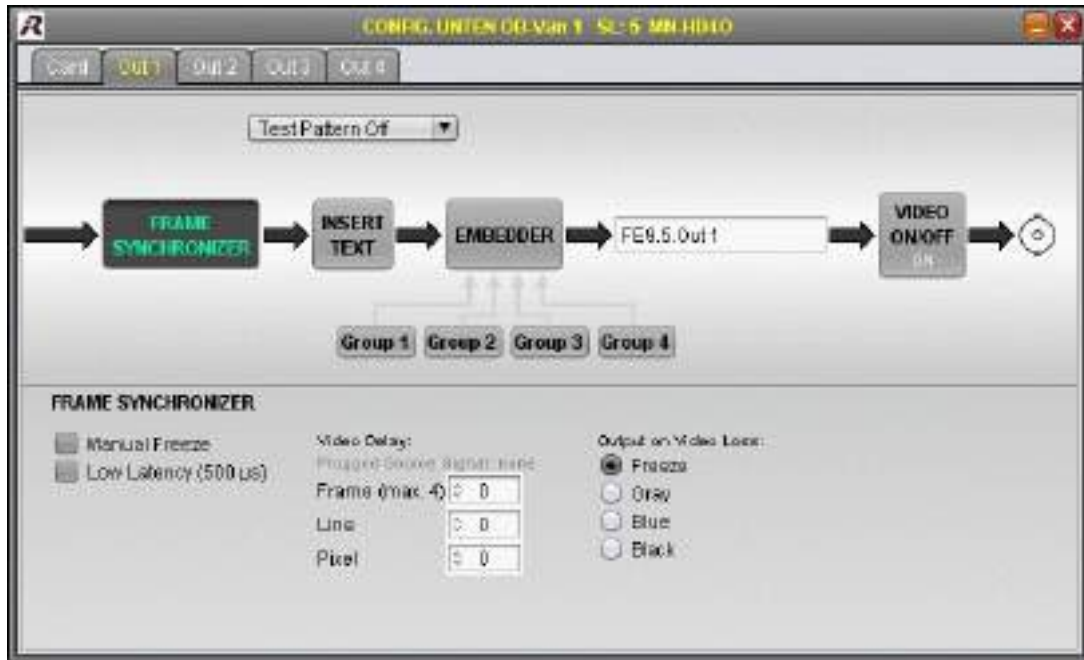

Figure 166: MN-HD40 Out CONFIGURATION

The meanings of the different fields are described in the table below:

Test Pattern	Enable / disable and format selection of the test pattern (see chapter Test Pattern).
FRAME SYNCHRONIZER	(see chapter Frame Synchronizer).
INSERT TEXT	This function overlays status information on the respective output signal (see chapter Insert Text).
EMBEDDER	Selection of Audio groups 1 to 4 to embed Audio signals (see chapter Embedder).
Name	Name of the Channel (here FE9.5 Out 1)
VIDEO ON/OFF	Enable / disable of the Video output signal.

USO RESTRITTO

5.7.7.5 MN-HDO-4IO CONFIGURATION

In the headline is the name of the Frame, the name of the MN-HDO-4IO as well as the slot shown.

▼ MN-HDO-4IO Card CONFIGURATION



Figure 167: MN-HDO-4IO Card CONFIGURATION

In this field the name of the Card can be entered or changed.

USO RESTRITO

▼ MN-HDO-4IO In CONFIGURATION

The contents of the tabs *In 1* to *In 4* have the same structure.

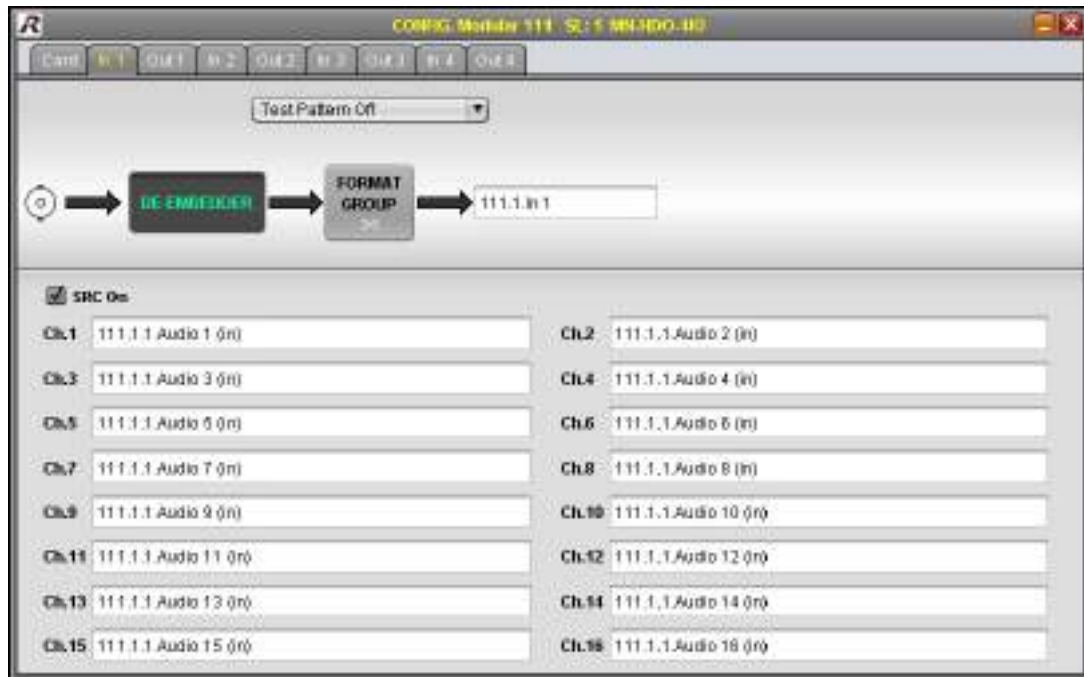

Figure 168: MN-HDO-4IO In CONFIGURATION

The meanings of the different fields are described in the table below:

Test Pattern	Enable / disable and format selection of the test pattern (see chapter Test Pattern).
	Excluding of the 16 Audio SubChannels (see chapter De-Embedder).
	Determination of required bandwidth of respective Channel (see chapter Format Group). 3G is only on Channel 1 and 2 available (see chapter Supported Formats).
Name	Name of the Channel (here 111.1 In 1)

USO RESTRITTO

▼ MN-HDO-4IO Out CONFIGURATION

The contents of the tabs *Out 1* to *Out 4* have the same structure.

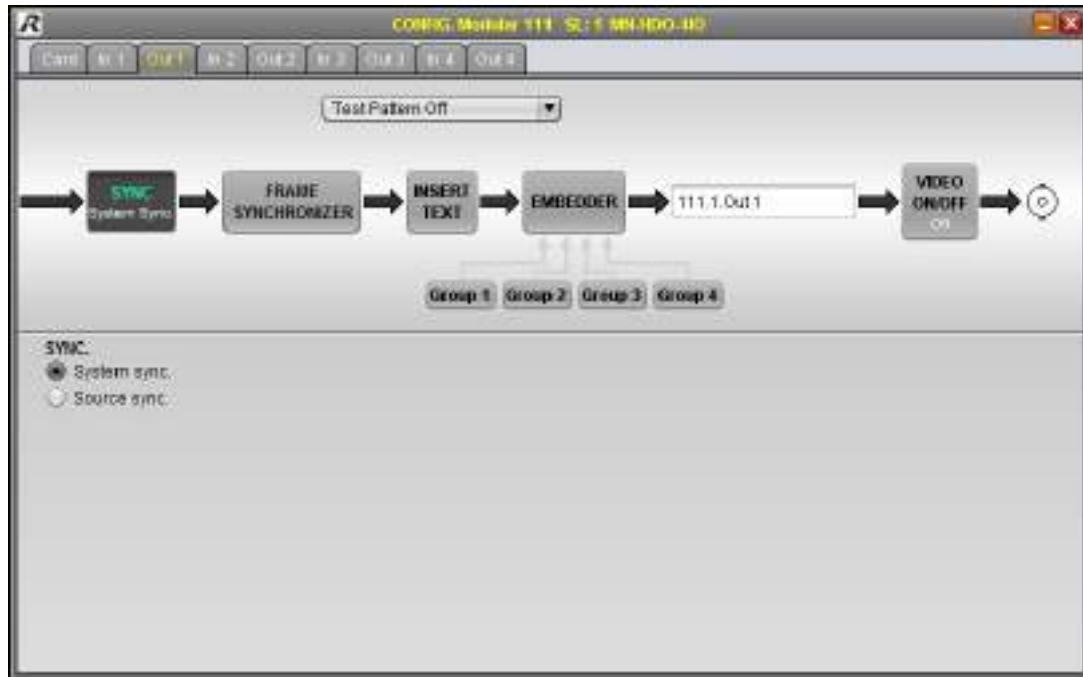

Figure 169: MN-HDO-4IO Out CONFIGURATION

The meanings of the different fields are described in the table below:

Test Pattern	Enable / disable and format selection of the test pattern (see chapter Test Pattern).
Sync	<p>System sync: Video signal at output is synchronized to the system clock.</p> <p>Source sync: Video signal at output keeps the same phase of the input signal.</p>
FRAME SYNCHRONIZER	(see chapter Frame Synchronizer).
INSERT TEXT	This function overlays status information on the respective output signal (see chapter Insert Text).
EMBEDDER	Selection of Audio groups 1 to 4 to embed Audio SubChannels (see chapter EMBEDDER).
Name	Name of the Channel (here 111.1 Out 1)
VIDEO ON/OFF On	Enable / disable of the Video output signal.

USO RESTRITTO

5.7.7.6 MN-HD(P)6 CONFIGURATION

The CONFIGURATION - window of MN-HD6 and MN-HDP6 are identical.

The difference to the MN-HDP6 is the additional *Processing* tab for the signal conversion and the Quad-Split.

In the headline is the name of the Frame, the name of the MN-HD(P)6 as well as the slot shown.

▼ MN-HD(P)6 Card CONFIGURATION



Figure 170: MN-HD(P)6 Card CONFIGURATION

The meanings of the different fields are described in the table below:

Card Name	Name of the Card
Channel 3 Mode	Selection of signal direction of Channel 3 (input / output)
Channel 4 Mode	Selection of signal direction of Channel 4 (input / output)

USO RESTRITO

▼ MN-HD(P)6 In CONFIGURATION

The contents of the tabs *In 1* to *In 4* have the same structure.

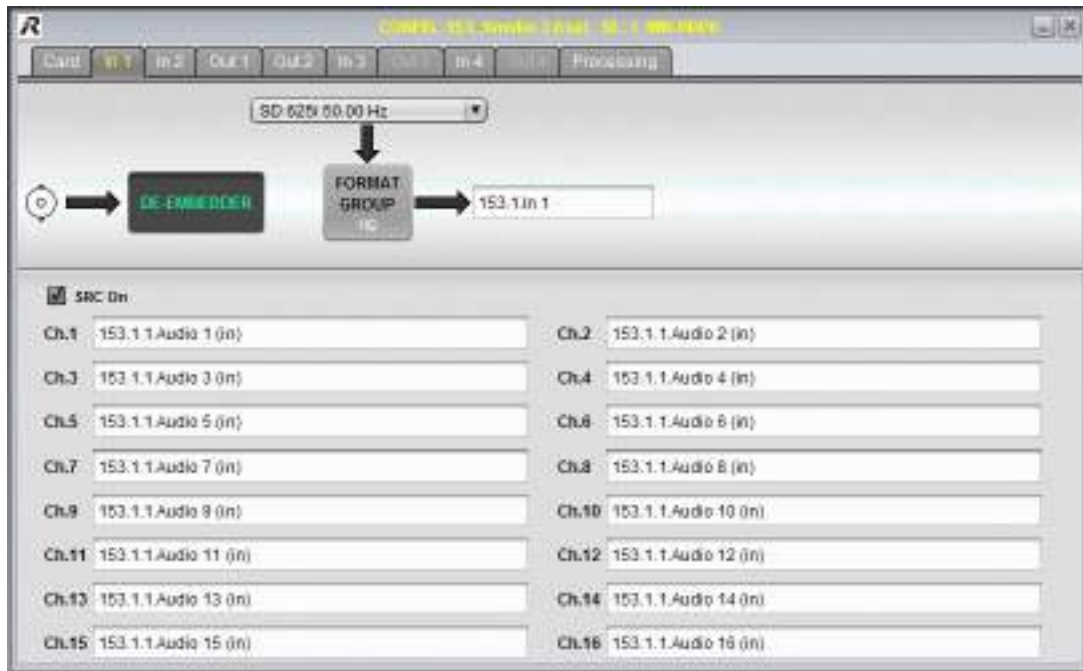



Figure 171: MN-HD(P)6 In CONFIGURATION

The meanings of the different fields are described in the table below:

Test Pattern	Enable / disable and format selection of the test pattern (see chapter Test Pattern).
	Excluding of the 16 Audio SubChannels (see chapter De-Embedder).
	Determination of required bandwidth of respective Channel (see chapter Format Group). 3G is only on Channel 1 and 2 available (see chapter Supported Formats).
Name	Name of the Channel (here 153.1 In 1)

USO RESTRITTO

▼ MN-HD(P)6 Out CONFIGURATION

The contents of the tabs *Out 1* to *Out 4* have the same structure.

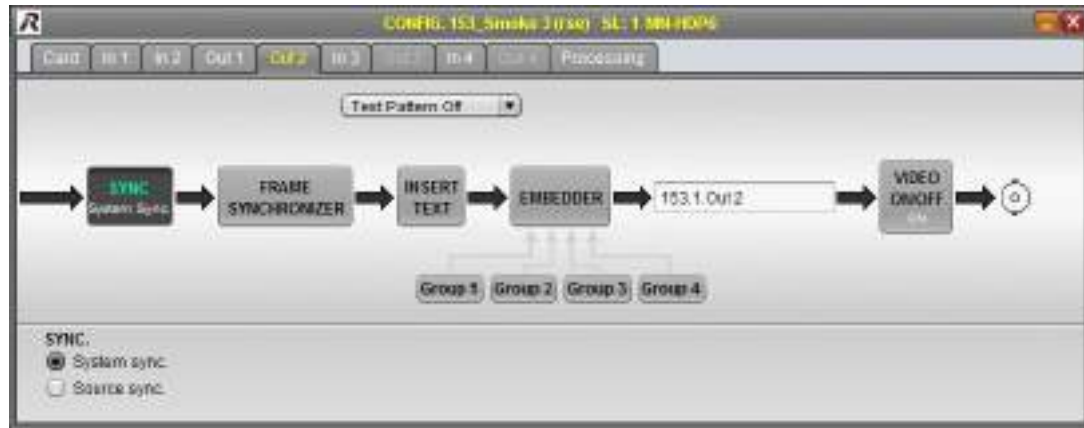

Figure 172: MN-HD(P)6 Out CONFIGURATION

The meanings of the different fields are described in the table below:

Test Pattern	Enable / disable and format selection of the test pattern (see chapter Test Pattern).
Sync	System sync: Video signal at output is synchronized to the system clock. Source sync: Video signal at output keeps the same phase of the input signal.
FRAME SYNCHRONIZER	(see chapter Frame Synchronizer).
INSERT TEXT	This function overlays status information on the respective output signal (see chapter Insert Text).
EMBEDDER	Selection of Audio groups 1 to 4 to embed Audio SubChannels (see chapter EMBEDDER).
Name	Name of the Channel (here 153.1 Out 2)
VIDEO DWOFF ON	Enable / disable of the Video output signal.

USO RESTRITTO

▼ MN-HDP6 Processing CONVERSION CONFIGURATION

This tab is only available on a MN-HDP6 Card.

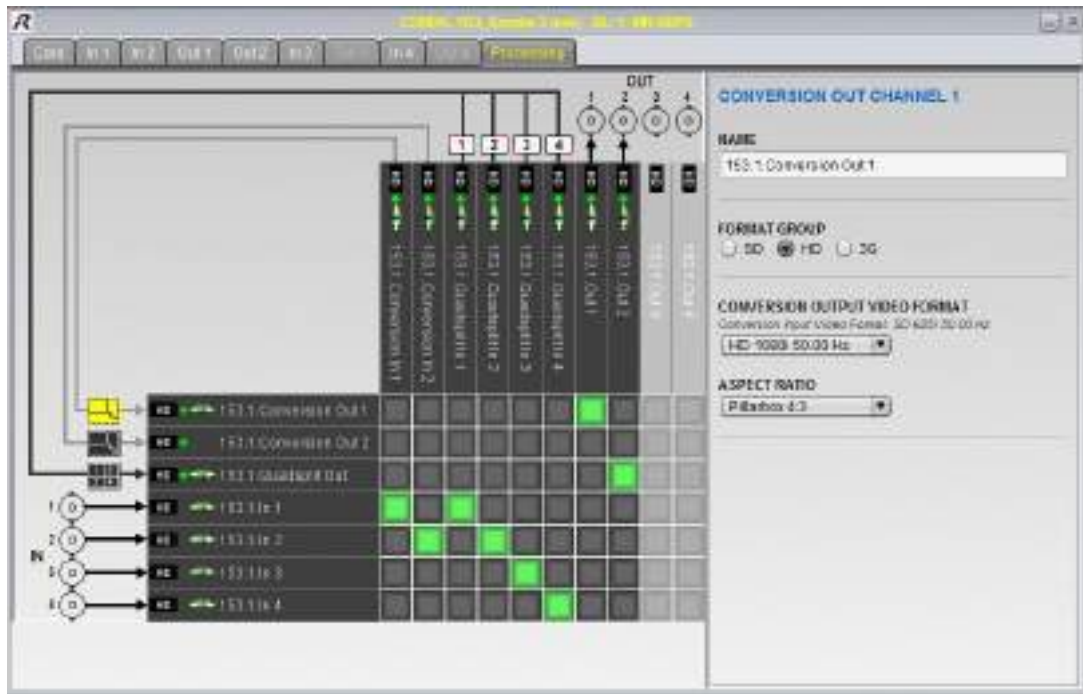

Figure 173: MN-HDP6 Processing CONVERSION CONFIGURATION

The meanings of the different fields are described in the table below:

Name	Name of the Channel.
Format Group	Determination of required bandwidth (SD, HD, 3G).
Conversion Output Video Format	Selection of the output format. (depending of the signal format of the input).
Aspect Ratio	Selection of the aspect ratio of the output signal.
Matrix	Routing of internal signals (routings to other Cards are possible in the Device Browser).

USO RESTRITTO

▼ MN-HDP6 Processing QUAD CONFIGURATION

This tab is only available on a MN-HDP6 Card.

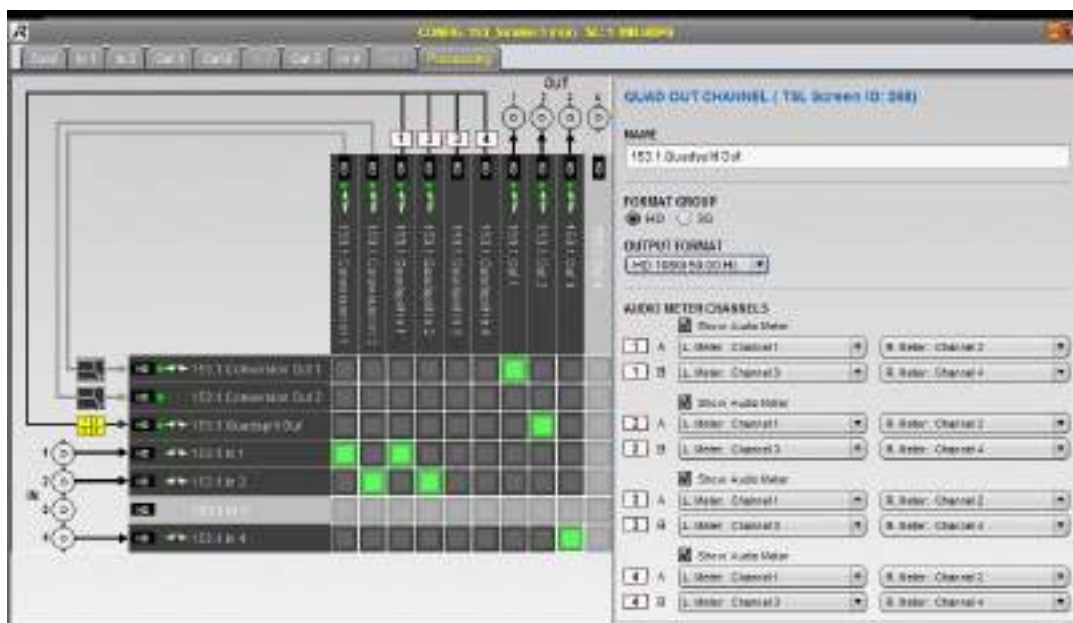

Figure 174: MN-HDP6 Processing QUAD CONFIGURATION

The meanings of the different fields are described in the table below:

Name	Name of the Channel.
Format Group	Determination of required bandwidth (HD, 3G).
Output Format	Selection of the output format (1080i/p 50/59.94/60 Hz).
Show Audio Meter	Disable / enable of the Audio meter of each QUAD-Channel.
Audio Meter Channels	Selection of left and right Audio Channel, if <i>Show Audio Meter</i> is enabled.
Matrix	Routing of internal signals (routings to other Cards are possible in the Device Browser).

USO RESTRITTO

5.7.7.7 MN-MA2EO CONFIGURATION

In the headline is the name of the Frame, the name of the MN-MA2EO as well as the slot shown.

▼ MN-MA2-EO Card CONFIGURATION

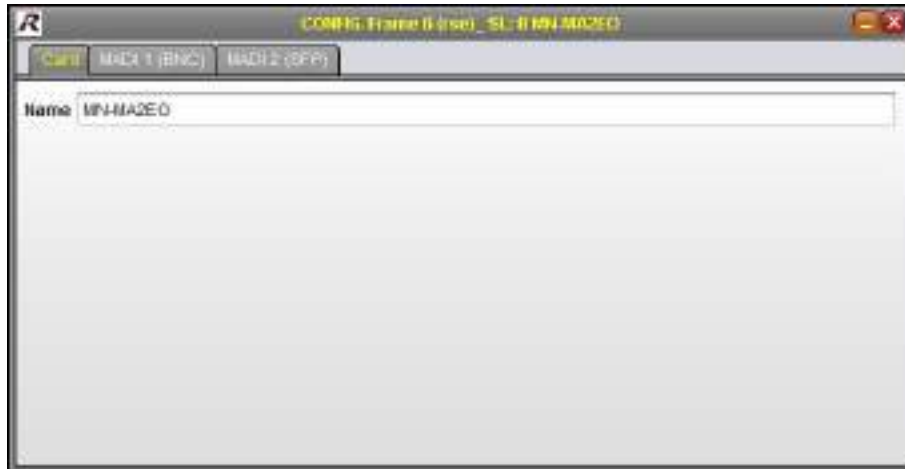

Figure 175: MN-MA2EO Card CONFIGURATION

In this field the name of the Card can be entered or changed.

USO RESTRITO

▼ MN-MA2-EO MADI CONFIGURATION

The contents of the tabs *MADI 1 (BNC)* and *MADI 2 (SFP)* have the same structure.



Figure 176: MN-MA2EO MADI CONFIGURATION

The meanings of the different fields are described in the table below:

Sample Rate	Selection of the sample rate (48kHz/96kHz)
Mono Out Channels	Selection of the number of MADI SubChannels: 64/56/56+1 in 48kHz sample rate mode 32/28/28+1 in 96kHz sample rate mode
(Left) Input MADI / Mono Channel Name	Name of the MADI-Input Channel / -SubChannels
(Right) Output MADI / Mono Channel Name	Name of the MADI-Output Channel / -SubChannels

On the right of the MADI Output-Channels / -SubChannels are the symbols for the 1kHz test signal and the muting. A left-click on these icons will enable/disable the function.

USO RESTRITTO

5.7.7.8 MN-RN300 CONFIGURATION

In the headline is the name of the Frame, the name of the MN-RN300 as well as the slot shown.

▼ MN-RN300 Card CONFIGURATION



Figure 177: MN-RN300 Card CONFIGURATION

In this field the name of the Card can be entered or changed.

USO RESTRITO

▼ MN-RN300 RockNet CONFIGURATION

The contents of the tabs *RockNet 1* and *RockNet 2* have the same structure.



Figure 178: MN-RN300 RockNet CONFIGURATION

The meanings of the different fields are described in the table below:

Sample Rate	Selection of the sample rate (48kHz/96kHz)
(Left) Input MADI / Mono Channel Name	Name of the RockNet-Input Channel / -SubChannels
(Right) Output MADI / Mono Channel Name	Name of the RockNet-Output Channel / -SubChannels

On the right of the RockNet Output-Channels / -SubChannels are the symbols for the 1kHz test signal and the muting. A left-click on these icons will enable/disable the function.

	The amount of available RockNet-SubChannels depends on the selected sample rate: 64 SubChannels in 48kHz sample rate mode 32 SubChannels in 96kHz sample rate mode
--	--

USO RESTRITTO

5.7.7.9 MN-MIO CONFIGURATION

In the headline is the name of the Frame, the name of the MN-MIO as well as the slot shown.

▼ MN-MIO Card CONFIGURATION



Figure 179: MN-MIO Card CONFIGURATION

The meanings of the different fields are described in the table below:

Name	Name of the Card
Audio Out SR	Selection of the Audio output sample rate (48kHz / 96kHz)

USO RESTRITO

▼ MN-MIO Analog In CONFIGURATION



Figure 180: MN-MIO Analog In CONFIGURATION

The meanings of the different fields are described in the table below:

Channel	Channel number of the input
Name	Name of the input

USO RESTRITO

▼ MN-MIO Analog Out CONFIGURATION



Figure 181: MN-MIO Analog Out CONFIGURATION

The meanings of the different fields are described in the table below:

Channel	Channel number of the output
Name	Name of the output
Testsignal	Enable / disable of the 1kHz test signals
Delay	Adjustment of the Audio delay. Maximum delay of 1000ms.
Mute	Enable / disable of output signal



The Delay can be changed either by up & down arrow-cursor-keys or by the mouse-wheel:
 Mouse-wheel or arrow-cursor key only: 1 step, with pressed *ALT*-key: 10 steps, with pressed *SHIFT*-key: 100 steps.

USO RESTRITTO

▼ MN-MIO AES In CONFIGURATION

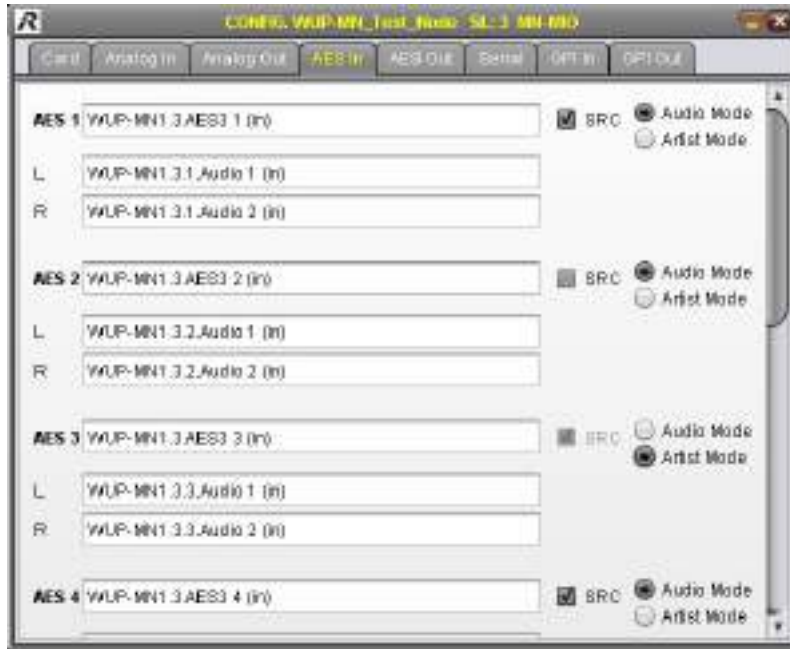

Figure 182: MN-MIO AES In CONFIGURATION

The meanings of the different fields are described in the table below:

AES Channel	Channel number of the input (AES / left / right)
Name	Name of the input
SRC	Activated sample rate converter will synchronize an asynchronous AES signal to the MediorNet clock.
Audio- / Artist-Mode	The embedded User-Bits in the AES-stream are passed through the system. In Artist-Mode these Bits are replaced by Artist-Panels relevant information.

USO RESTRITTO

▼ MN-MIO AES Out CONFIGURATION



Figure 183: MN-MIO AES Out CONFIGURATION

The meanings of the different fields are described in the table below:

AES Channel	Channel number of the output (AES / left / right)
Name	Name of the output
Testsignal	Enable / disable of the 1kHz test signals
Audio- / Artist-Mode	Audio Mode is used when AES signal is connected. Artist Mode is used when an Artist-panel is connected.
Delay	Adjustment of the Audio delay. Maximum delay of 1000ms.
Mute	Enable / disable of output signal



The Delay can be changed either by up & down arrow-cursor-keys or by the mouse-wheel:
 Mouse-wheel or arrow-cursor key only: 1 step, with pressed *ALT*-key: 10 steps, with pressed *SHIFT*-key: 100 steps.

USO RESTRITTO

▼ MN-MIO Serial CONFIGURATION

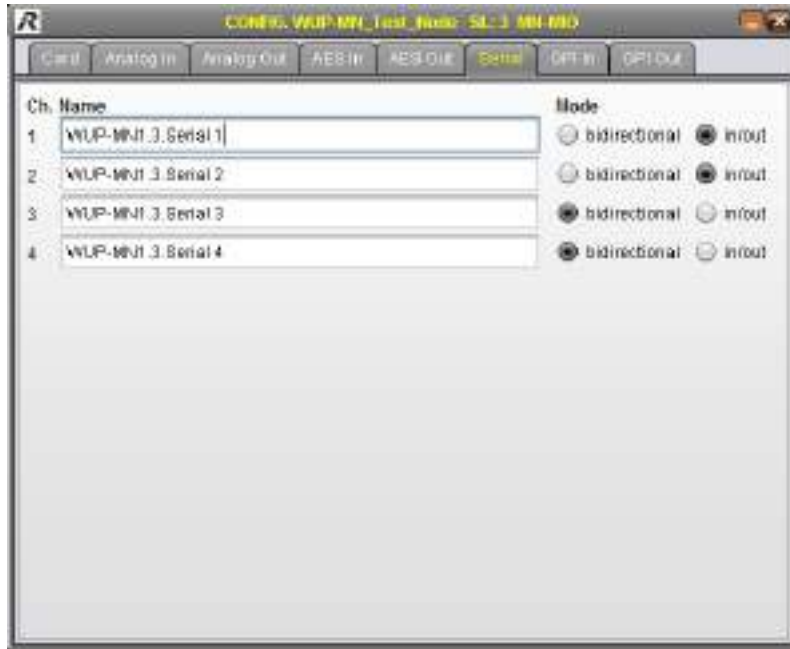

Figure 184: MN-MIO Serial CONFIGURATION

The meanings of the different fields are described in the table below:

Channel	Channel number of the Channel
Name	Name of the Channel
Mode	Bidirectional is used to receive and transmit a combined signal. In/out is used two receive and transmit two independent signals.

USO RESTRITTO

▼ MN-MIO GPI In CONFIGURATION

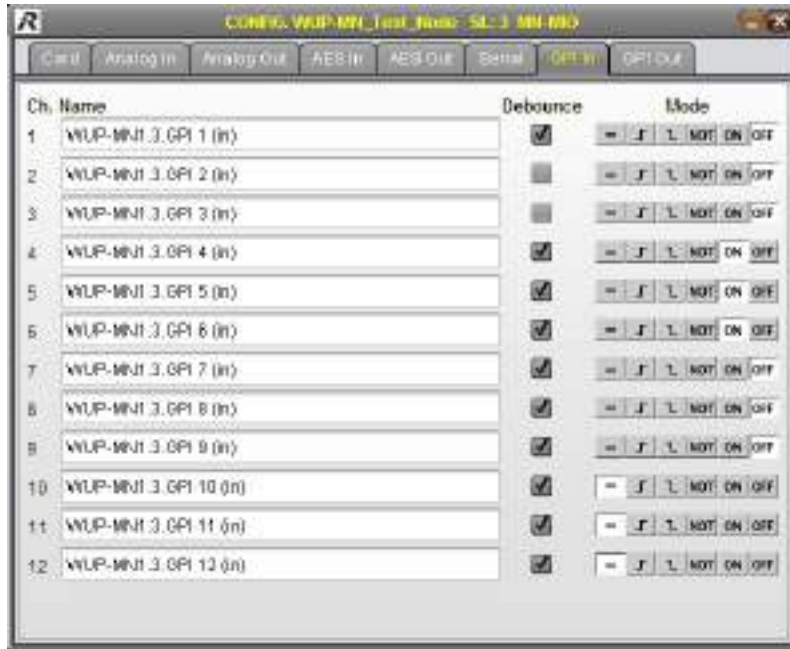

Figure 185: MN-MIO GPI In CONFIGURATION

The meanings of the different fields are described in the table below:

Channel	Channel number of the input
Name	Name of the input
Debounce	Enable / disable of input debouncing (delay of 100ms)
Mode	Selection to control GPI: loop through / triggered on positive slope / triggered on negative slope / inverted loop through / permanent on / permanent off

USO RESTRITTO

▼ MN-MIO GPI Out CONFIGURATION



Figure 186: MN-MIO GPI Out CONFIGURATION

The meanings of the different fields are described in the table below:

Channel	Channel number of the output
Name	Name of the output
Mode	Selection to control GPI: loop through / triggered on positive slope / triggered on negative slope / inverted loop through / permanent on / permanent off

USO RESTRITTO

5.7.7.10 MN-ETH6 CONFIGURATION

In the headline is the name of the Frame, the name of the MN-ETH6 as well as the slot shown.

▼ MN-ETH6 Card CONFIGURATION

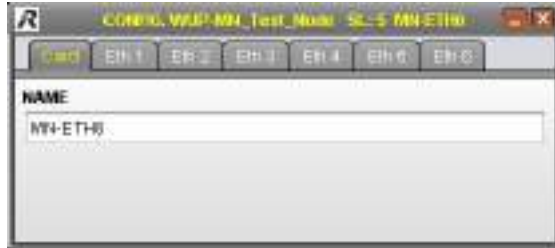

Figure 187: MN-ETH6 Card CONFIGURATION

In this field the name of the Card can be entered or changed.

▼ MN-ETH6 Eth 1-6 CONFIGURATION

The contents of the tabs *Eth 1* to *Eth 6* have the same structure.



Figure 188: MN-ETH6 CONFIGURATION

Additional 1000BaseT Ethernet Packets can be tunneled via the six ports on the MN-ETH6 Card via the fiber. In this window the name of the Channel can be entered or changed and the required bandwidth can be selected.

USO RESTRITTO

5.7.7.11 MN-GV2 CONFIGURATION

In the headline is the name of the Frame, the name of the MN-GV2 as well as the slot shown.

▼ MN-GV-2 Card CONFIGURATION



Figure 189: MN-GV2 Card CONFIGURATION

The meanings of the different fields are described in the table below:

Name	Name of the Card
Broadcast Format	Selection of the output signal format (PAL, NTSC) depending on the input signal. No format conversion is performed. See chapter Formats .

	<p>If the broadcast format is changed via LDK Connect Gateway in the Grass Valley System, a few seconds need to pass before the respective format is configured in MediorWorks. The Grass Valley Subsystem needs to terminate first the handshake in the previous format. If the configuration is changed too early, the camera could be configured differently as the Base Station and no more communication via MediorNet would be possible.</p>
---	--

USO RESTRITTO

▼ MN-GV-2 Port 1-2 CONFIGURATION

The contents of the tabs *Port 1* and *Port 2* have the same structure.



Figure 190: MN-GV2 Port CONFIGURATION

The meanings of the different fields are described in the table below:

Input Name	Name of the Input
Output Name	Name of the Output
Interface Mode	Determination of the connected device (Camera/Base Station)
Camera Speed	Determination of required bandwidth of respective Channel (HD/3G)
De-Embedder Audio Channels	INTERFACE MODE set to Camera Interface : All 6 channels are de-embedded.
	INTERFACE MODE set to Base Station Interface : Only channels 1 to 4 are de-embedded.
Embedder Audio Channels	INTERFACE MODE set to Camera Interface : Only channels 1 to 4 can be embedded.
	INTERFACE MODE set to Base Station Interface : All 6 channels can be embedded.
Embedder Checkbox	Only channels with checked box are embedded.

5.7.7.12 MN-ST-AL2 CONFIGURATION

In the headline is the name of the Frame, the name of the MN-ST-AL2 as well as the slot shown.

USO RESTRITTO

▼ MN-ST-AL2 Card CONFIGURATION



Figure 191: MN-ST-AL2 Card CONFIGURATION

In this field the name of the Card can be entered or changed.

USO RESTRITTO

▼ MN-ST-AL2 A-Link CONFIGURATION

The contents of the tabs *A-Link 1* and *A-Link 2* have the same structure.



Figure 192: MN-ST-AL2 A-Link CONFIGURATION

The meanings of the different fields are described in the table below:

Redundancy Mode	
Main preferred	If both SFPs receive a signal, the signal of the Main-SFP is used.
Main preferred combining	If both SFPs receive a signal, each sample of both Audio streams are compared. The samples of the Main-SFP are used if they are valid. If the samples of the Main-SFP are invalid, the signal of the Redundant-SFP is used.
Main only	The samples of the Redundant-SFP are used only.
Redundant preferred	If both SFPs receive a signal, the signal of the Redundant-SFP is used.
Redundant preferred combining	If both SFPs receive a signal, each sample of both Audio streams are compared. The samples of the Redundant-SFP are used if they are valid. If the samples of the Redundant-SFP are invalid, the signal of the Main-SFP is used.
Redundant only	The samples of the Redundant-SFP are used only.

The left column **IN** contains the names of the inputs and the right column **OUT** contains the names of the outputs.

On the right of the output name is the symbol for the 1kHz test signal and the muting. A left-click on these icons will enable/disable the function.

USO RESTRITTO

5.7.7.13 MN-Compact Frame CONFIGURATION

In the headline is the name of the Frame shown.

▼ MN-Compact Frame CONFIGURATION



Figure 193: MN-Compact Frame CONFIGURATION

USO RESTRITO

The meanings of the different fields are described in the table below:

Frame Long Name	Detailed name of the Frame.
Frame Short Name	Short name of the Frame. This is also the default prefix for the Channel names.
Apply Short Name	Apply the entered short name.
System Location	Location information
System Contact	Contact information (f.i. in case of trouble)
LED Brightness	The brightness of the status LEDs of the Frame can be adjusted between 0% - 100% (exceptions are the Fan and PSU)
Audio Sample Rate	Selection of the Sample Rate (48kHz/96kHz).
Output Synchronization	Definition of the signal format of the Sync Out port on the MN-Compact see chapter Supported synchronization formats .
Leading Sync.	By checking the checkbox "Leading Sync Out", the Sync signal at the SYNC OUT port of this Frame is generated 500µs before the MediorNet wide sync signal.
TC Mode	Selection of Timecode format (PAL/NTSC/NTSC DF).
VITC Out ¹	By checking the checkbox <i>VITC Out</i> , the MediorNet Timecode is embedded in the Sync-Signal.
User Notes	empty field for the user to enter any notes

¹ This checkbox is only available, if the parameter **Sync. Out** is set to *Blackburst PAL* or *Blackburst NTSC*.

The synchronization settings can be set also in the windows [Frame Synchronization](#).



The brightness can be changed either by up & down arrow-cursor-keys or by the mouse-wheel: Mouse-wheel or arrow-cursor key only: 1 step, with pressed *ALT*-key: 5 steps, with pressed *SHIFT*-key: 10 steps.

USO RESTRITTO

5.7.7.14 MN-Compact Main CONFIGURATION

In the headline is the name of the Frame shown.

▼ MN-Compact Main Card CONFIGURATION

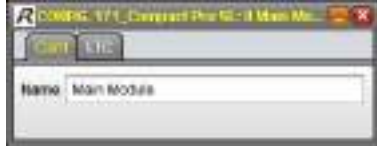

Figure 194: MN-Compact Main Card CONFIGURATION

In this field the name of the main module can be entered or changed.

▼ MN-Compact Main LTC CONFIGURATION

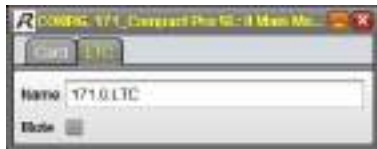

Figure 195: MN-Compact Main LTC CONFIGURATION

The meanings of the different fields are described in the table below:

Name	Name of the LTC input
Mute	Enabled muting will disconnect the external LTC at the Audio input and the LTC Channel. In this case the timecode is no longer available for the system.

USO RESTRITTO

5.7.7.15 MN-Compact Video In CONFIGURATION

In the headline is the name of the Frame and the Video In Card as well as the slot shown.

▼ MN-Compact Video In Card CONFIGURATION



Figure 196: MN-Compact Video In Card CONFIGURATION

In this field the name of the Card can be entered or changed.

USO RESTRITO

▼ MN-Compact Video In CONFIGURATION

The contents of the tabs *In 1* to *In 4* have the same structure.



Figure 197: MN-Compact Video In CONFIGURATION

The meanings of the different fields are described in the table below:

Test Pattern	Enable / disable and format selection of the test pattern (see chapter Test Pattern).
	Excluding of the 16 Audio SubChannels (see chapter De-Embedder).
	Determination of required bandwidth of respective Channel (see chapter Format Group).
Name	Name of the Channel (here A1C.1 In 1)

USO RESTRITTO

5.7.7.16 MN-Compact Video Out CONFIGURATION

In the headline is the name of the Frame and the Video Out Card as well as the slot shown.

▼ MN-Compact Video Out Card CONFIGURATION



Figure 198: MN-Compact Video Out Card CONFIGURATION

In this field the name of the Card can be entered or changed.

USO RESTRITO

▼ MN-Compact Video Out CONFIGURATION

The contents of the tabs *Out 1* to *Out 4* have the same structure.

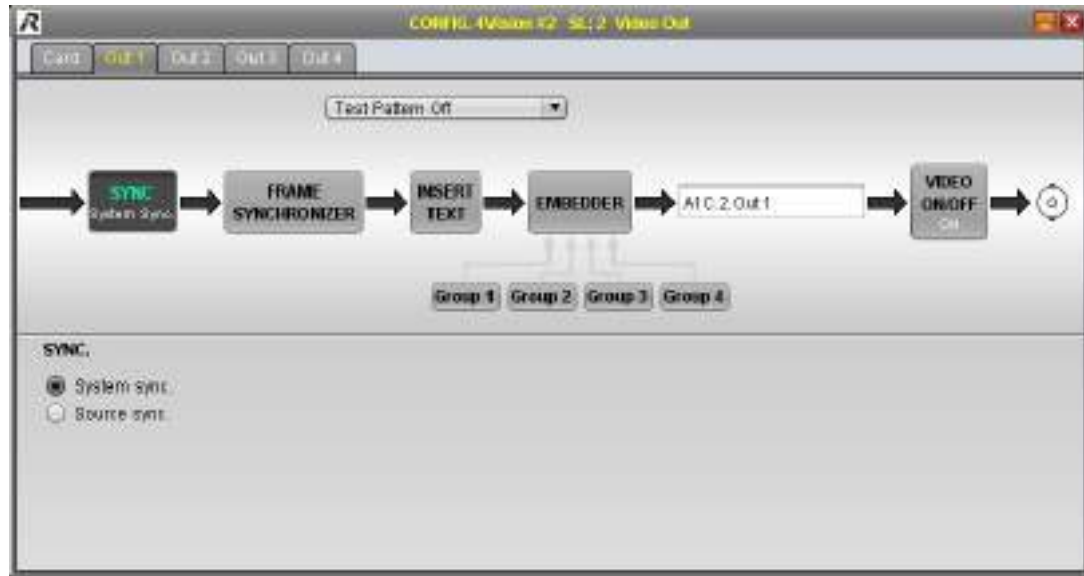

Figure 199: MN-Compact Video Out CONFIGURATION

The meanings of the different fields are described in the table below:

Test Pattern	Enable / disable and format selection of the test pattern (see chapter Test Pattern).
Sync	<p>System sync: Video signal at output is synchronized to the system clock.</p> <p>Source sync: Video signal at output keeps the same phase of the input signal.</p>
FRAME SYNCHRONIZER	(see chapter Frame Synchronizer).
INSERT TEXT	This function overlays status information on the respective output signal (see chapter Insert Text).
EMBEDDER	Selection of Audio groups 1 to 4 to embed Audio SubChannels (see chapter EMBEDDER).
Name	Name of the Channel (here A1C.2 Out 1)
VIDEO ON/OFF ON	Enable / disable of the Video output signal.

USO RESTRITTO

5.7.7.17 MN-Compact MADI CONFIGURATION

In the headline is the name of the Frame and the MADI Card as well as the slot shown.

▼ MN-Compact MADI Card CONFIGURATION



Figure 200: MN-Compact MADI Card CONFIGURATION

In this field the name of the Card can be entered or changed.

USO RESTRITO

▼ MN-Compact MADI 1-2 CONFIGURATION

The contents of the tabs *MADI 1* and *MADI 2* have the same structure.

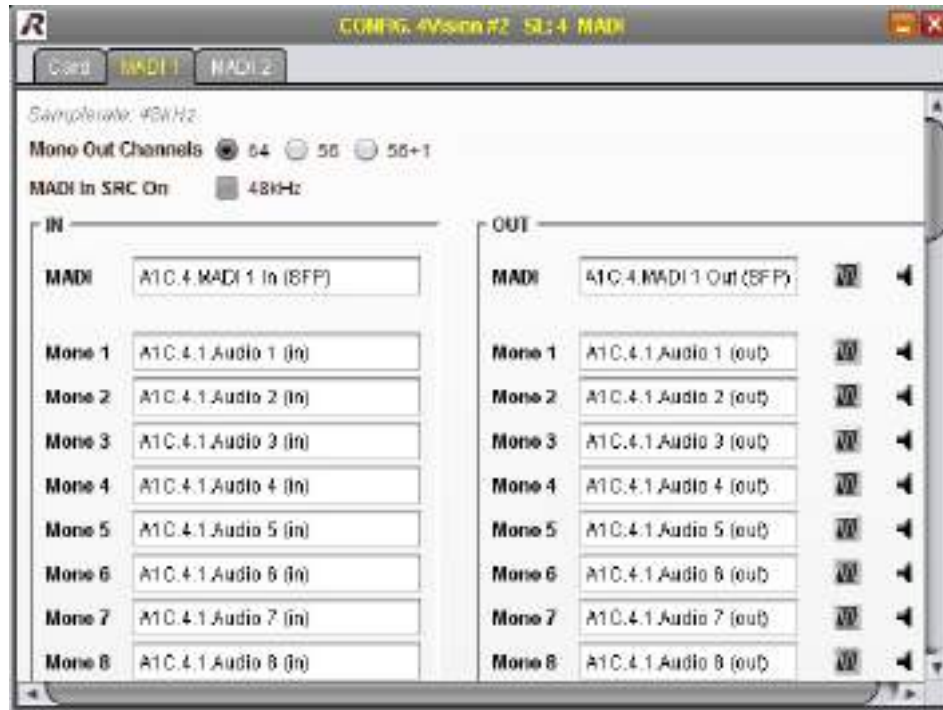

Figure 201: MN-Compact MADI CONFIGURATION

The meanings of the different fields are described in the table below:

Mono Out Channels	Selection of the number of MADI SubChannels: 64/56/56+1 in 48kHz sample rate mode 32/28/28+1 in 96kHz sample rate mode
MADI In SRC On	Enabling the sample rate converter (only 48 kHz)
(Left) Input MADI / Mono Channel Name	Name of the MADI-Input Channel / -SubChannels
(Right) Output MADI / Mono Channel Name	Name of the MADI-Output Channel / -SubChannels

On the right of the MADI Output-Channels / -SubChannels are the symbols for the 1kHz test signal and the muting. A left-click on these icons will enable/disable the function.

USO RESTRITO

5.7.7.18 MN-Compact RockNet CONFIGURATION

In the headline is the name of the Frame and the RockNet Card as well as the slot shown.

▼ MN-Compact RockNet Card CONFIGURATION



Figure 202: MN-Compact RockNet Card CONFIGURATION

In this field the name of the Card can be entered or changed.

USO RESTRITO

▼ MN-Compact RockNet 1-2 CONFIGURATION

The contents of the tabs *RockNet 1* and *RockNet 2* have the same structure.

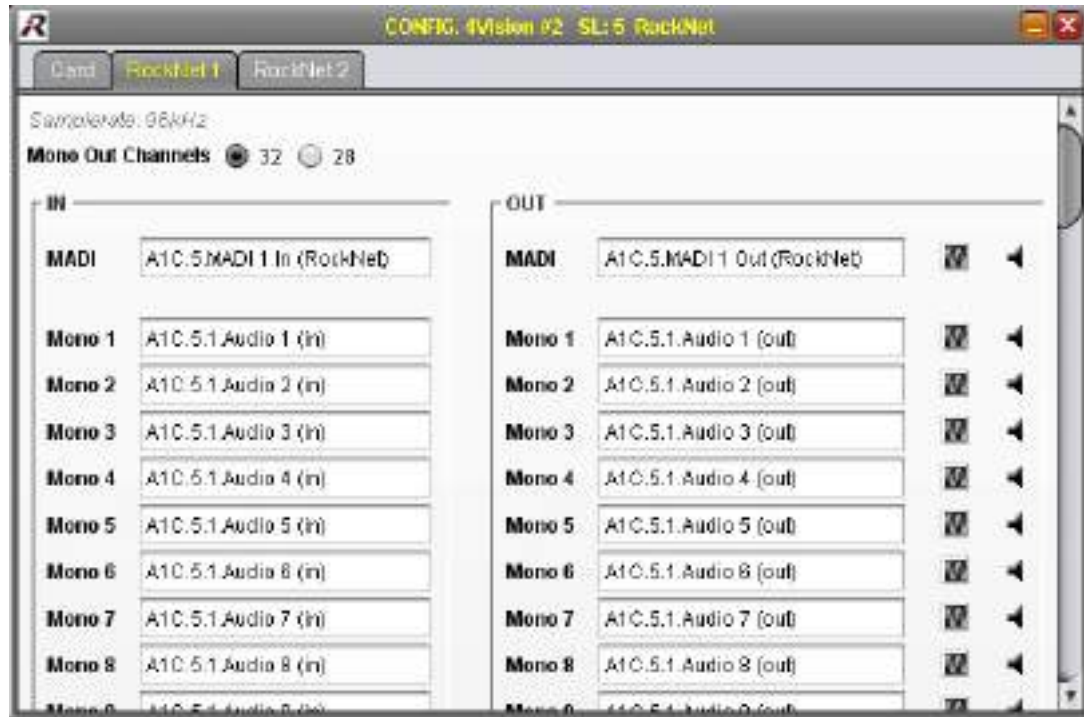

Figure 203: MN-Compact RockNet CONFIGURATION

The meanings of the different fields are described in the table below:

Mono Out Channels	Selection of the number of RockNet SubChannels: 64/56 in 48kHz sample rate mode 32/28 in 96kHz sample rate mode
(Left) Input MADI / Mono Channel Name	Name of the RockNet-Input Channel / -SubChannels
(Right) Output MADI / Mono Channel Name	Name of the RockNet-Output Channel / -SubChannels

On the right of the RockNet Output-Channels / -SubChannels are the symbols for the 1kHz test signal and the muting. A left-click on these icons will enable/disable the function.

USO RESTRITO

5.7.7.19 MN-Compact AES Audio CONFIGURATION

In the headline is the name of the Frame and the AES Audio Card as well as the slot shown.

▼ MN-Compact AES Audio Card CONFIGURATION



Figure 204: MN-Compact AES Audio Card CONFIGURATION

In this field the name of the Card can be entered or changed.

USO RESTRITO

▼ MN-Compact AES Audio In CONFIGURATION

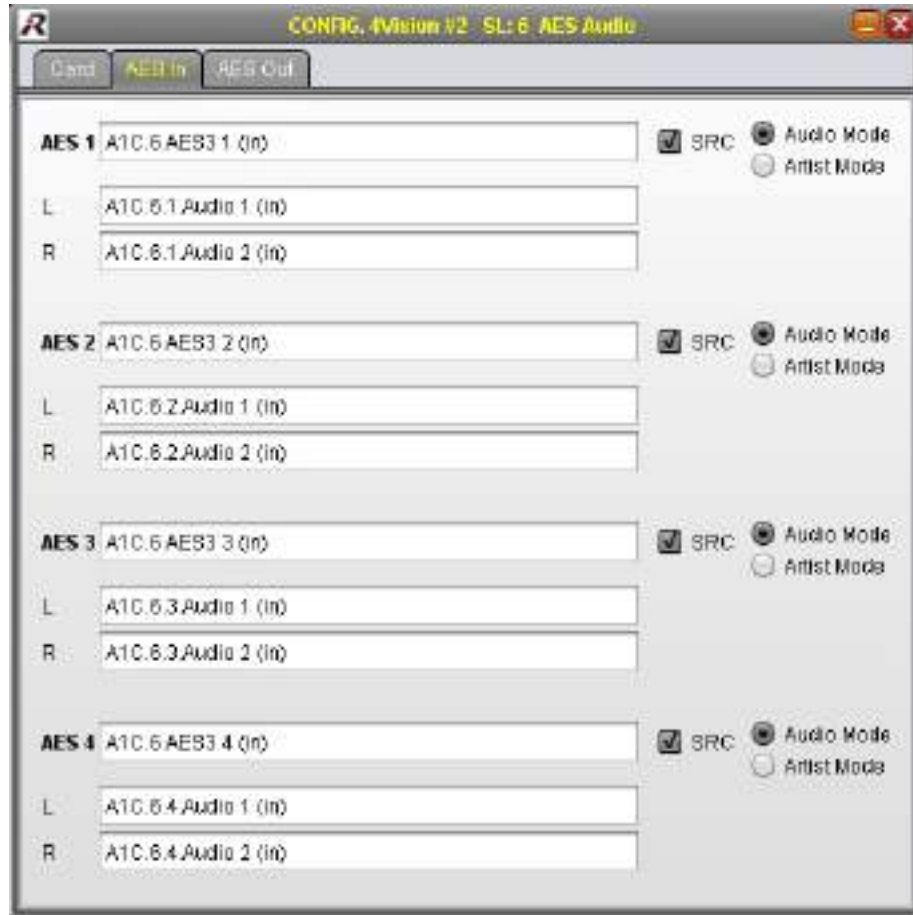

Figure 205: MN-Compact AES Audio In CONFIGURATION

The meanings of the different fields are described in the table below:

AES Channel	Channel number of the input (AES / left / right)
Name	Name of the input
SRC	Activated sample rate converter will synchronize an asynchronous AES signal to the MediorNet clock.
Audio- / Artist-Mode	In Audio-Mode the embedded User-Bits in the AES-stream are passed through the system. In Artist-Mode these Bits are replaced by Artist-Panels relevant information.

USO RESTRITTO

▼ MN-Compact AES Audio Out CONFIGURATION



Figure 206: MN-Compact AES Audio Out CONFIGURATION

The meanings of the different fields are described in the table below:

AES Channel	Channel number of the output (AES / left / right)
Name	Name of the output
Testsignal	Enable / disable of the 1kHz test signals
Audio- / Artist-Mode	In Audio-Mode the embedded User-Bits in the AES-stream are passed through the system. In Artist-Mode these Bits are replaced by Artist-Panels relevant information.
Delay	Adjustment of the Audio delay. Maximum delay of 1000ms.
Mute	Enable / disable of output signal



The values of the field Delay can be changed either by up & down arrow-cursor-keys or by the mouse-wheel: Mouse-wheel or arrow-cursor key only: 1 step, with pressed *ALT*-key: 10 steps, with pressed *SHIFT*-key: 100 steps.

USO RESTRITTO

5.7.7.20 MN-Compact Analog Audio CONFIGURATION

In the headline is the name of the Frame and the Analog Audio Card as well as the slot shown.

The MN-Compact Analog Audio CONFIGURATION window will **not** be automatically re-opened, if it was open while closing MediorWorks.

▼ MN-Compact Analog Audio Card CONFIGURATION

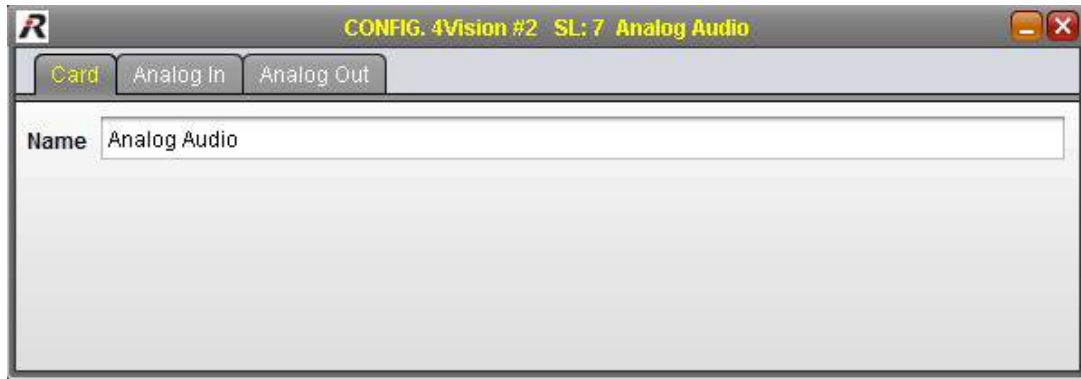

Figure 207: MN-Compact Analog Audio Card CONFIGURATION

In this field the name of the Card can be entered or changed.

USO RESTRITO

▼ MN-Compact Analog Audio In CONFIGURATION



Figure 208: MN-Compact Analog Audio In CONFIGURATION

The meanings of the different fields are described in the table below:

Ch.	Channel number of the input
Name	Name of the input
Phantom	+48V Microphone Phantom Power on/off
Pad	18dB Signal attenuation on/off
Gain	The Gain range (11 to 66 dB, without Pad) can be entered with the keyboard in the text field. The icon  in front of the text field opens a fader and offers the entry by mouse.
Level	A green bar indicates the actual level in dBFS. A red bar indicates clipping above 0 dBFS.

Only one MediorWorks instance, with any numbers of Analog-In Configuration-Windows, can be connected to each Compact Frame.

All fields except the name fields are disabled and the Text Busy appears on the bottom of the window, if another MediorWorks instance opens the same Analog-In Configuration-Window.

This limitation is due to performance reasons



Figure 209: MN-Compact Analog Audio In CONFIGURATION Busy

USO RESTRITTO

▼ MN-Compact Analog Audio Out CONFIGURATION

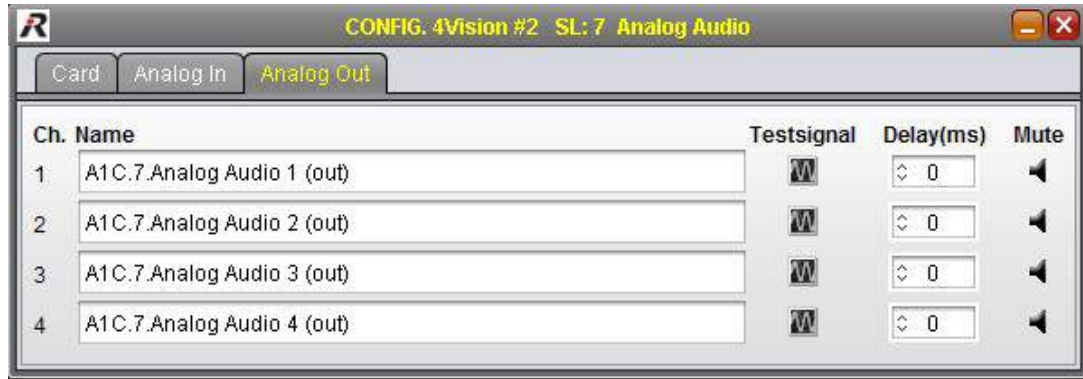

Figure 210: MN-Compact Analog Audio Out CONFIGURATION

The meanings of the different fields are described in the table below:

Channel	Channel number of the output
Name	Name of the output
Testsignal	Enable / disable of the 1kHz test signals
Delay	Adjustment of the Audio delay. Maximum delay of 1000ms.
Mute	Enable / disable of output signal

The values of the field Delay can be changed either by up & down arrow-cursor-keys or by the mouse-wheel: Mouse-wheel or arrow-cursor key only: 1 step, with pressed *ALT*-key: 10 steps, with pressed *SHIFT*-key: 100 steps.

USO RESTRITTO

5.7.7.21 MN-Compact Ethernet CONFIGURATION

In the headline is the name of the Frame and the Ethernet Card as well as the slot shown.

▼ MN-Compact Ethernet Card CONFIGURATION



Figure 211: MN-Compact Ethernet Card CONFIGURATION

In this field the name of the Card can be entered or changed.

▼ MN-Compact Ethernet 1-3 CONFIGURATION

The contents of the tabs *Eth 1* to *Eth 3* have the same structure.

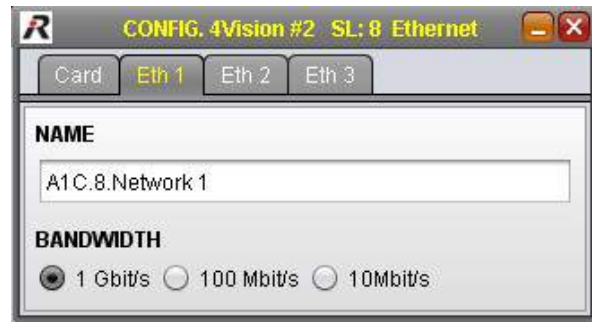

Figure 212: MN-Compact Ethernet CONFIGURATION

In this window the name of the Channel can be entered or changed and the required bandwidth can be selected.

USO RESTRITTO

5.7.7.22 MN-Compact Serial CONFIGURATION

In the headline is the name of the Frame and the Serial Card as well as the slot shown.

▼ MN-Compact Serial Card CONFIGURATION

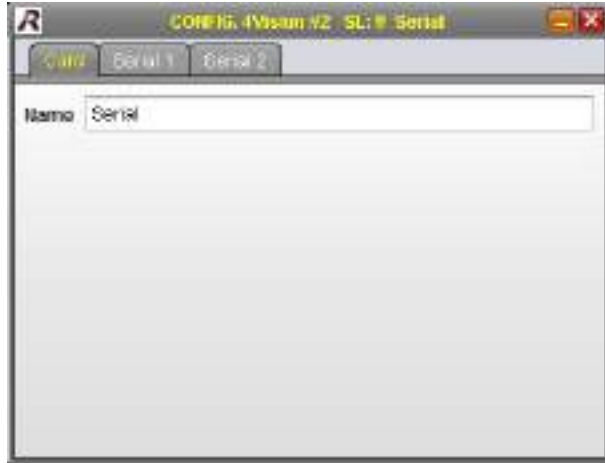

Figure 213: MN-Compact Serial Card CONFIGURATION

In this field the name of the Card can be entered or changed.

▼ MN-Compact Serial 1-2 CONFIGURATION

The contents of the tabs *Serial 1* and *Serial 2* have the same structure.



Figure 214: MN-Compact Serial CONFIGURATION

In this field the name of the Channel can be entered or changed.

Below the format of the serial signal can be selected via drop-down menu (RS 232, RS 422, RS 485).

Furthermore the routing mode can be selected between bidirectional and unidirectional.

If the RS 485 format is selected, a 120 Ω termination can be enabled by a checkbox.

On the right side is the pinout of the Sub-D 9 connector displayed. The pinout depends on the selected format.

USO RESTRITTO

5.7.7.23 MN-Compact GPI CONFIGURATION

In the headline is the name of the Frame and the GPI Card as well as the slot shown.

▼ MN-Compact GPI Card CONFIGURATION

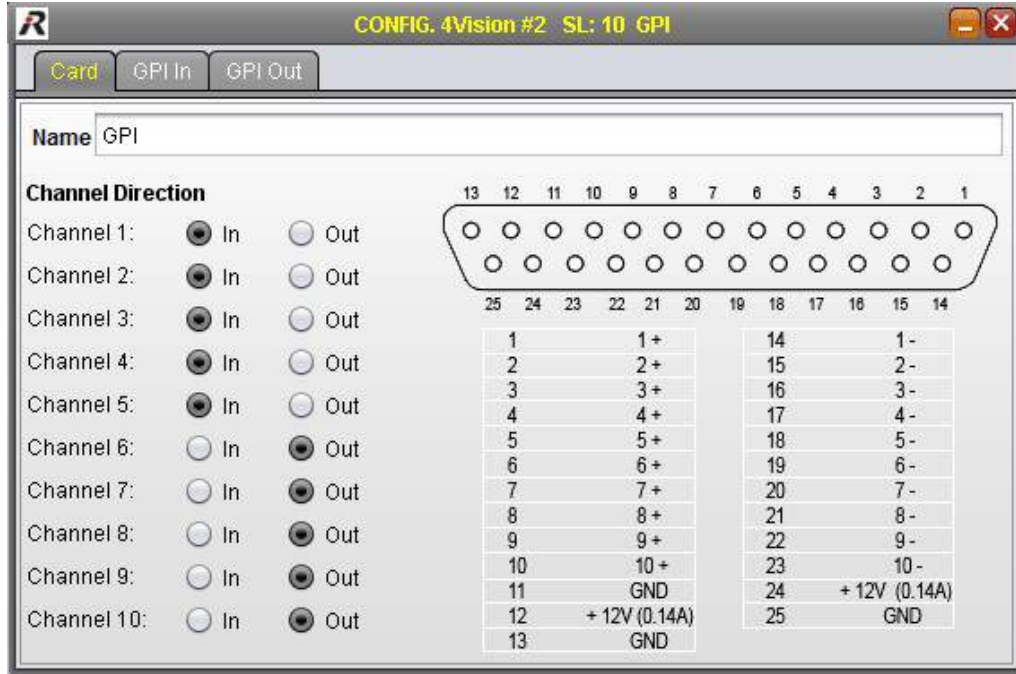

Figure 215: MN-Compact GPI Card CONFIGURATION

In this field the name of the Card can be entered or changed.
 Furthermore each single Channel can be set to an input or output Channel.
 On the right side is the pinout of the Sub-D 25 connector displayed.

USO RESTRITO

▼ MN-Compact GPI In CONFIGURATION

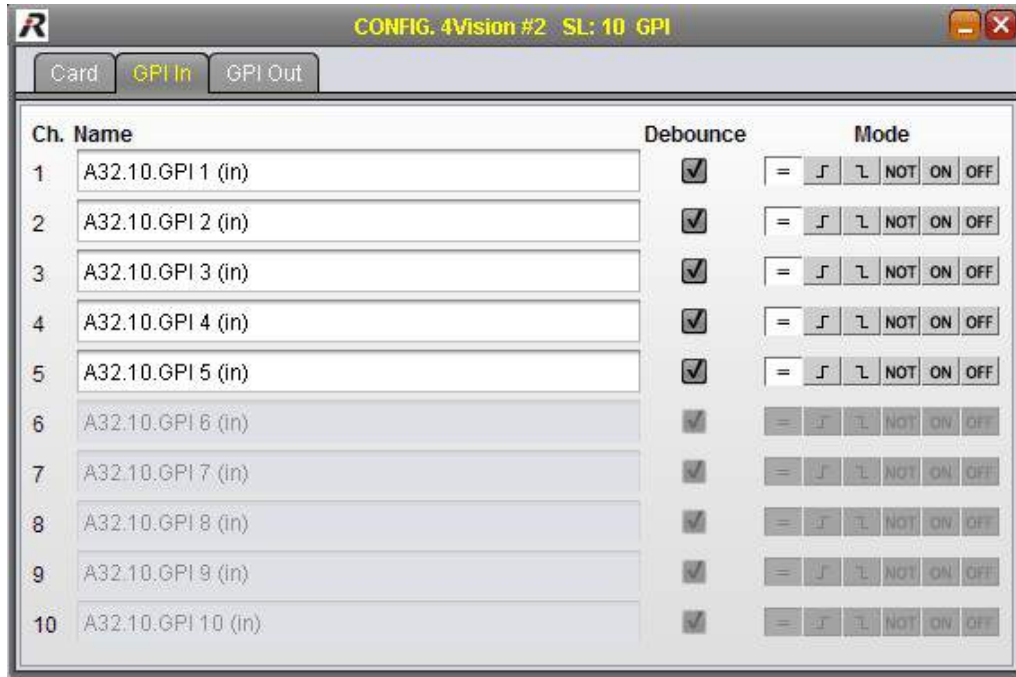

Figure 216: MN-Compact GPI In CONFIGURATION

The meanings of the different fields are described in the table below:

Channel	Channel number of the input
Name	Name of the input
Debounce	Enable / disable of input debouncing (delay of 100ms)
Mode	Selection to control GPI: loop through / triggered on positive slope / triggered on negative slope / inverted loop through / permanent on / permanent off

USO RESTRITTO

▼ MN-Compact GPI Out CONFIGURATION



Figure 217: MN-Compact GPI Out CONFIGURATION

The meanings of the different fields are described in the table below:

Channel	Channel number of the output
Name	Name of the output
Mode	Selection to control GPI: loop through / triggered on positive slope / triggered on negative slope / inverted loop through / permanent on / permanent off

USO RESTRITTO

5.7.7.24 MN-C-OPT-SDI CONFIGURATION

In the headline is the name of the Frame and the option Card as well as the slot shown.

The Compact-option Cards *SDI-8I*, *SDI-8O* and *SDI-4I4O* have the same structure. The difference is the amount of available in-/output channels.

SDI-8I	8 inputs
SDI-8O	8 outputs
SDI-4I4O	4 inputs, 4 outputs

▼ MN-C-OPT-SDI Card CONFIGURATION

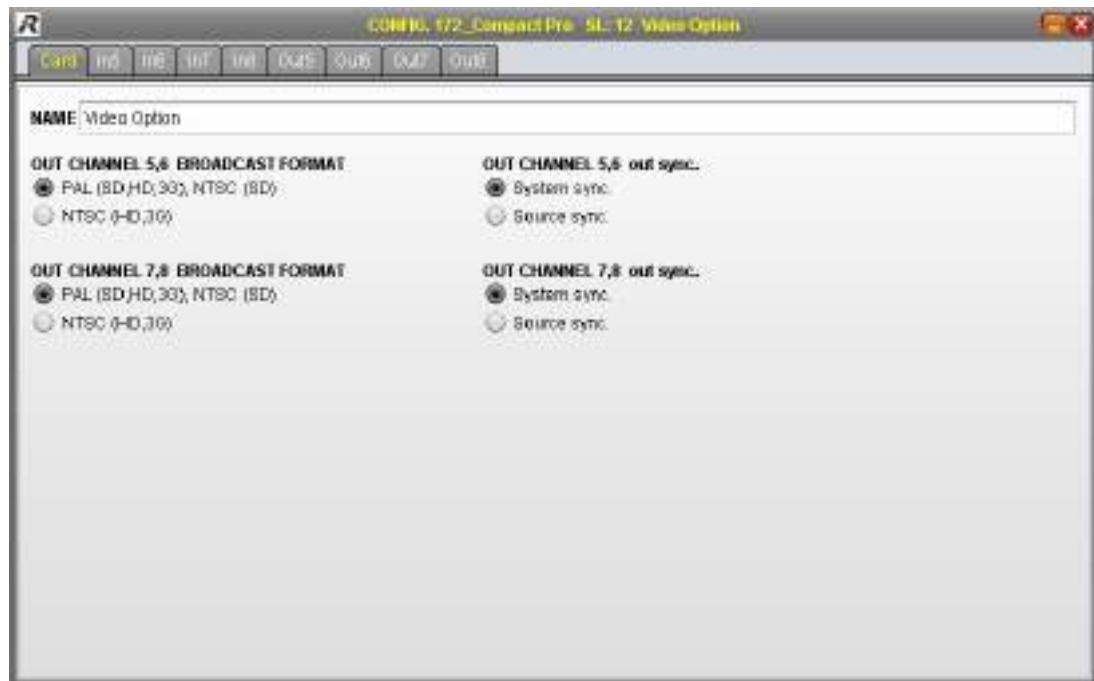

Figure 218: MN-C-OPT-SDI Card CONFIGURATION

The meanings of the different fields are described in the table below:

Name	Name of the Card
Channel x,y Broadcast Format	Selection of the output signal format (PAL, NTSC) depending on the input signal. No format conversion is performed. See chapter Supported Formats .
Channel x,y out sync	System sync: Video signal at output is synchronized to the system clock. Source sync: Video signal at output x keeps the same phase of the input signal. Output y disabled.

USO RESTRITTO

▼ MN-C-OPT-SDI In CONFIGURATION

The contents of the tabs *In x* have the same structure.



Figure 219: MN-C-OPT-SDI In CONFIGURATION

The meanings of the different fields are described in the table below:

Test Pattern	Enable / disable and format selection of the test pattern (see chapter Test Pattern).
	Excluding of the 16 Audio SubChannels (see chapter De-Embedder).
	Determination of required bandwidth of respective Channel (see chapter Format Group).
Name	Name of the Channel (here 176.12 In 5)

USO RESTRITTO

▼ MN-C-OPT-SDI Out CONFIGURATION

The contents of the tabs *Out x* have the same structure.

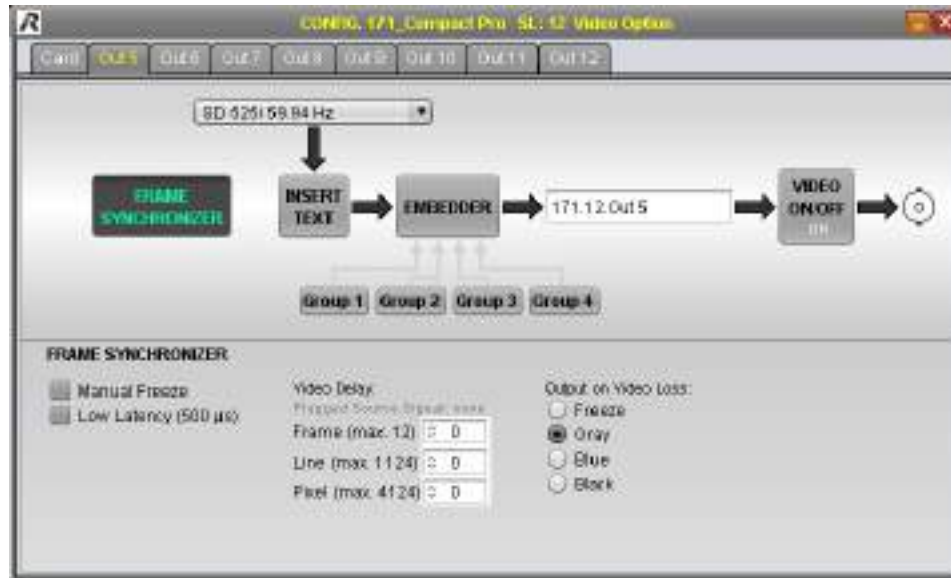

Figure 220: MN-C-OPT-SDI Out CONFIGURATION

The meanings of the different fields are described in the table below:

Test Pattern	Enable / disable and format selection of the test pattern (see chapter Test Pattern).
FRAME SYNCHRONIZER	(see chapter Frame Synchronizer).
INSERT TEXT	This function overlays status information on the respective output signal (see chapter Insert Text).
EMBEDDER	Selection of Audio groups 1 to 4 to embed Audio SubChannels (see chapter EMBEDDER).
Name	Name of the Channel (here 171.12 Out 5)
VIDEO ON/OFF	Enable / disable of the Video output signal.

USO RESTRITTO

5.7.7.25 MN-C-OPT-HDMI CONFIGURATION

In the headline is the name of the Frame and the option Card as well as the slot shown.

The Compact-option Cards *HDMI-4I*, *HDMI-4O* and *HDMI-2I2O* have the same structure. The difference is the amount of available in-/output channels.

HDMI-4I	4 inputs
HDMI-4O	4 outputs
HDMI-2I2O	2 inputs, 2 outputs

▼ MN-C-OPT-HDMI Card CONFIGURATION

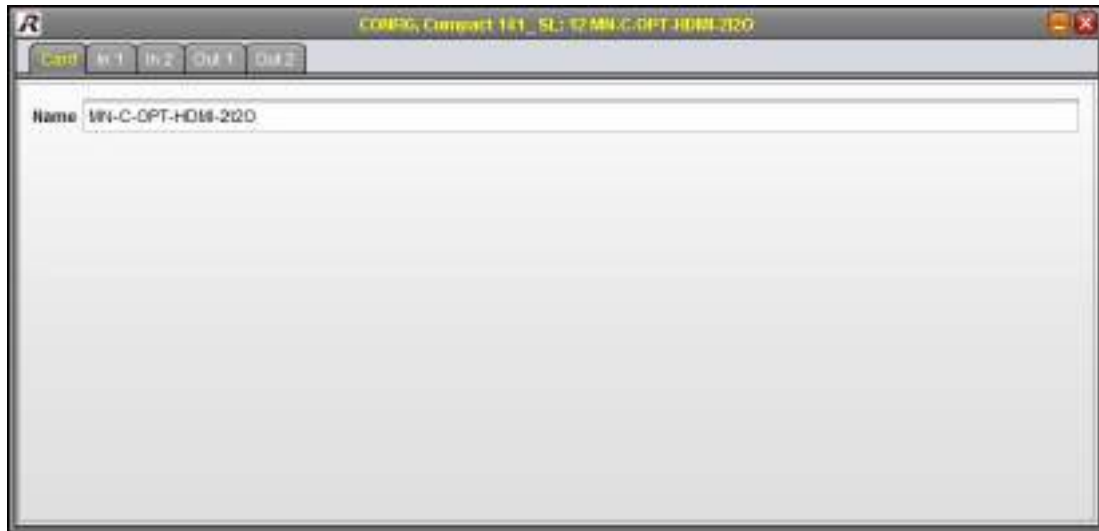

Figure 221: MN-C-OPT-HDMI Card CONFIGURATION

In this field the name of the Card can be entered or changed.

USO RESTRITO

▼ MN-C-OPT-HDMI In CONFIGURATION

The contents of the tabs *In x* have the same structure.

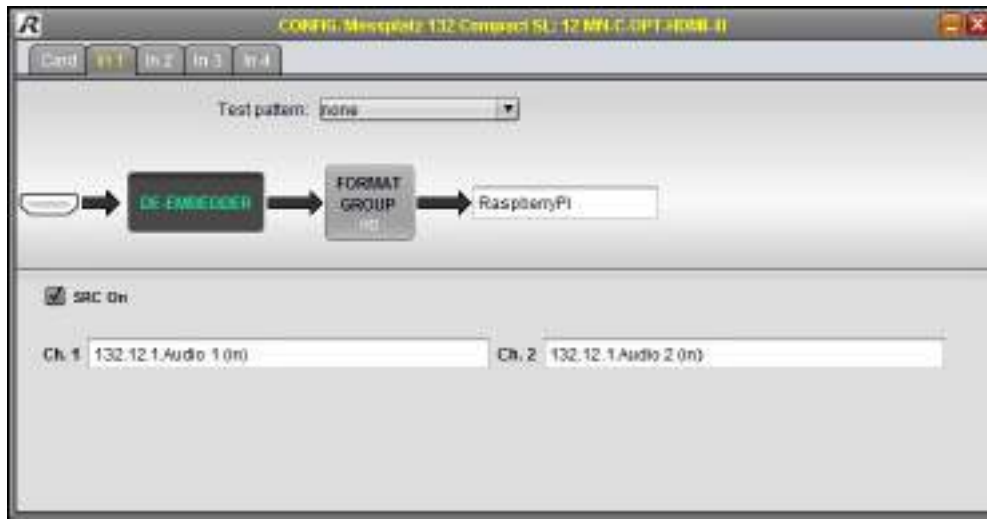

Figure 222: MN-C-OPT-HDMI In CONFIGURATION

The meanings of the different fields are described in the table below:

Test Pattern	Enable / disable and format selection of the test pattern (see chapter Test Pattern).
	Excluding of the 2 Audio SubChannels (see chapter De-Embedder).
	Determination of required bandwidth of respective Channel (see chapter Format Group).
Name	Name of the Channel (here RaspberryPi)

USO RESTRITTO

▼ MN-C-OPT-HDMI Out CONFIGURATION

The contents of the tabs *Out x* have the same structure.

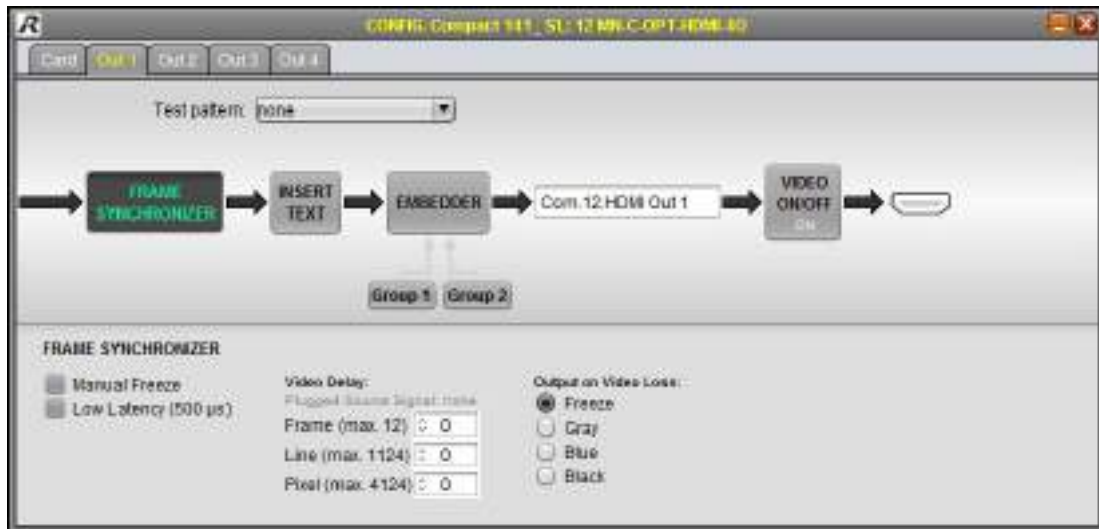

Figure 223: MN-C-OPT-HDMI Out CONFIGURATION

The meanings of the different fields are described in the table below:

Test Pattern	Enable / disable and format selection of the test pattern (see chapter Test Pattern).
FRAME SYNCHRONIZER	(see chapter Frame Synchronizer).
INSERT TEXT	This function overlays status information on the respective output signal (see chapter Insert Text).
EMBEDDER	Selection of 2 Audio groups to embed Audio SubChannels (see chapter EMBEDDER).
Name	Name of the Channel (here Com.12.HDMI Out 1)
VIDEO ON/OFF	Enable / disable of the Video output signal.

USO RESTRITTO

5.7.7.26 Test Pattern

Test patterns are available for the Video Channels as well as for the Audio SubChannels. The descriptions of Video and Audio patterns are split in the following chapters.

▼ Video Test Pattern

It is possible to generate different formats of test patterns in the single Video Channels. A test pattern can be selected and enabled/disabled by right-click in the *DEVICE BROWSER* or in the *MATRIX* on the desired Channel. Choose the option *Test Pattern* in the context menu and select one of the offered patterns.

The test pattern can also be activated in the *CONFIGURATION*-window of the Video Cards.

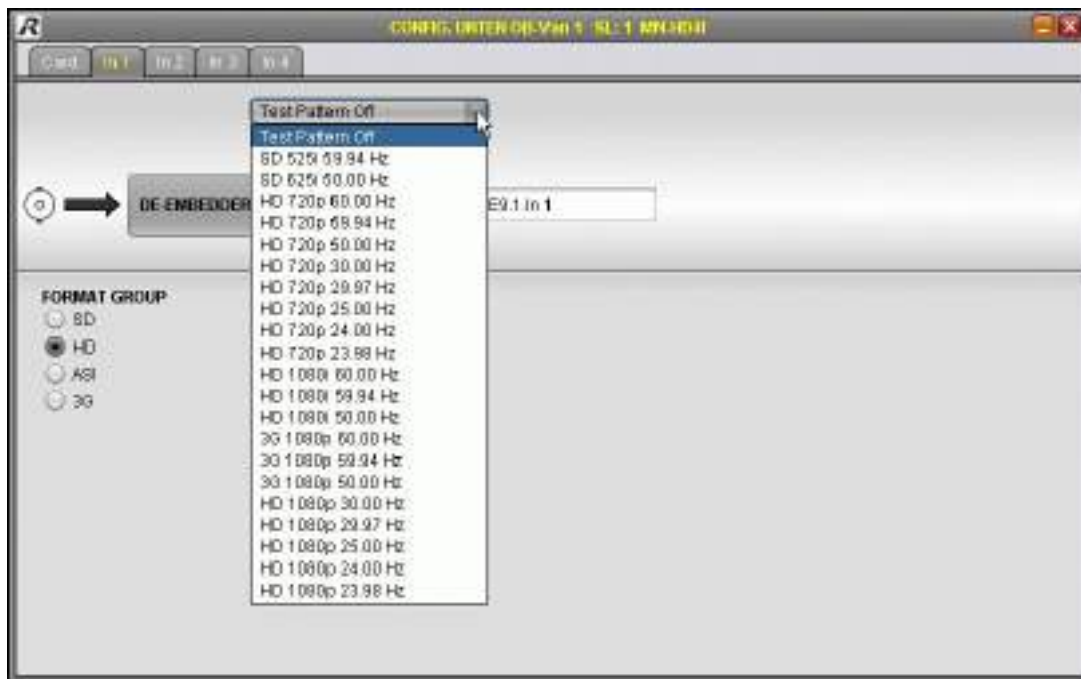

Figure 224: Test Pattern MN-HD1

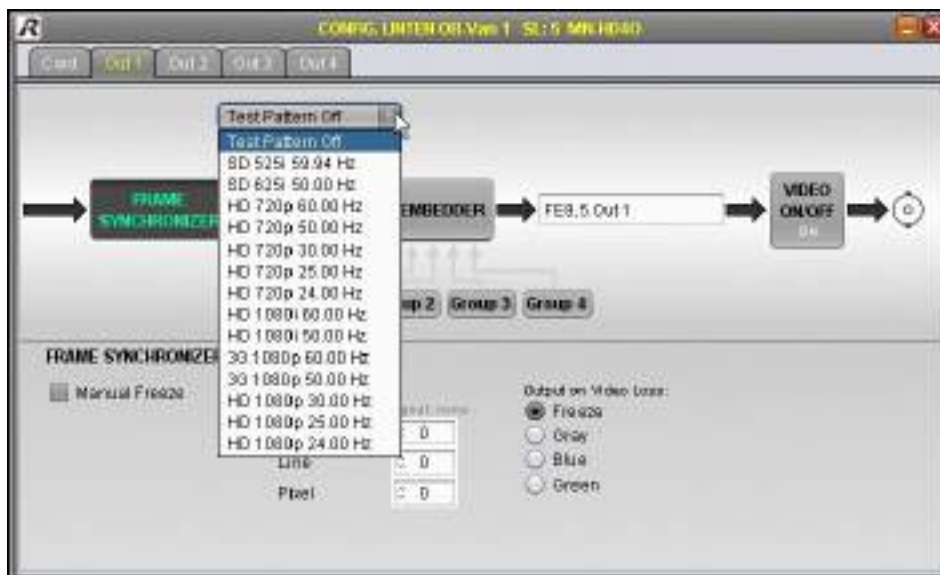

Figure 225: Test Pattern MN-HD1

USO RESTRITTO

In the following table are listed all Video test patterns of the Video input Card:

Off	Test pattern is disabled
SD 525i 59.94Hz 75%	Standard-Definition 525 interlaced pixel rows 59.94 Hz frame frequency 75% luminance
SD 525i 50.00Hz 75%	Standard-Definition 525 interlaced pixel rows 50.00 Hz frame frequency 75% luminance
HD 720p 60.00Hz 75%	High-Definition 720 progressive pixel rows 60.00 Hz frame frequency 75% luminance
3G 1080p 60.00Hz 75%	Full High-Definition 1080 progressive pixel rows 60.00 Hz frame frequency 75% luminance
SD 525i 59.94Hz 100%	Standard-Definition 525 interlaced pixel rows 59.94 Hz frame frequency 100% luminance
SD 525i 50.00Hz 100%	Standard-Definition 525 interlaced pixel rows 50.00 Hz frame frequency 100% luminance
HD 720p 60.00Hz 100%	High-Definition 720 progressive pixel rows 60.00 Hz frame frequency 100% luminance
3G 1080p 60.00Hz 100%	Full High-Definition 1080 progressive pixel rows 60.00 Hz frame frequency 100% luminance

USO RESTRITTO

Additional Test patterns are available on the Video output Card if configured in PAL mode:

HD 720p 50.00Hz	High-Definition 720 progressive pixel rows 50.00 Hz frame frequency 100% luminance
HD 720p 30.00Hz	High-Definition 720 progressive pixel rows 30.00 Hz frame frequency 100% luminance
HD 720p 25.00Hz	High-Definition 720 progressive pixel rows 25.00 Hz frame frequency 100% luminance
HD 720p 24.00Hz	High-Definition 720 progressive pixel rows 24.00 Hz frame frequency 100% luminance
HD 1080i 60.00Hz	High-Definition 1080 interlaced pixel rows 60.00 Hz frame frequency 100% luminance
HD 1080i 50.00Hz	High-Definition 1080 interlaced pixel rows 50.00 Hz frame frequency 100% luminance
3G 1080p 50.00Hz	Full High-Definition 1080 progressive pixel rows 50.00 Hz frame frequency 100% luminance
HD 1080p 30.00Hz	High-Definition 1080 progressive pixel rows 30.00 Hz frame frequency 100% luminance
HD 1080p 25.00Hz	High-Definition 1080 progressive pixel rows 25.00 Hz frame frequency 100% luminance
HD 1080p 24.00Hz	High-Definition 1080 progressive pixel rows 24.00 Hz frame frequency 100% luminance

USO RESTRITO

Additional Test patterns are available on the Video output Card if configured in NTSC mode:

HD 720p 59.94Hz	High-Definition 720 progressive pixel rows 59.94 Hz frame frequency 100% luminance
HD 720p 29.97Hz	High-Definition 720 progressive pixel rows 29.97 Hz frame frequency 100% luminance
HD 720p 23.98Hz	High-Definition 720 progressive pixel rows 23.98 Hz frame frequency 100% luminance
HD 1080i 59.94Hz	High-Definition 1080 interlaced pixel rows 59.94 Hz frame frequency 100% luminance
3G 1080p 59.94Hz	Full High-Definition 1080 progressive pixel rows 59.94 Hz frame frequency 100% luminance
HD 1080p 29.97Hz	High-Definition 1080 progressive pixel rows 29.97 Hz frame frequency 100% luminance
HD 1080p 23.98Hz	High-Definition 1080 progressive pixel rows 23.98 Hz frame frequency 100% luminance

▼ Audio Test Pattern

On the Audio Cards it's possible to generate an Audio test signal (1 kHz Sinus -6 dBFS) for each Audio Channel individually. This can be done in the *DEVICE BROWSER* and in the *MATRIX* by a right-click on the desired Channel and choosing the option *Test Signal On* in the context menu. The test signal can also be activated in the *CONFIGURATION*-window.

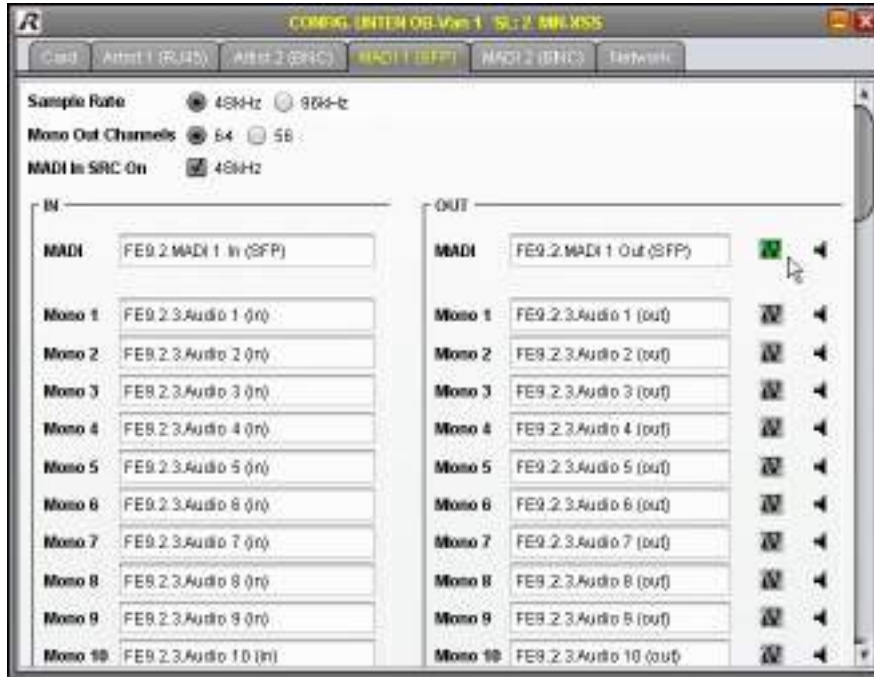

Figure 226: Test Signal MN-XSS MADI

USO RESTRITTO

5.7.7.27 DE-EMBEDDER / EMBEDDER

MediorNet offers the possibility to embed or de-embed, depending on the used media Card, a different amount of mono Audio SubChannels of every SDI Video signal.

The De-Embedder function is integrated in every Video input Card. The Embedder is integrated on every Video output Card. In this way it is possible to de-embed the Audio SubChannels on the input Card and route them separately in the MediorNet network.

▼ DE-EMBEDDER

The De-Embedder is available on Video input Cards. Dependent of the used media Card, up to 16 mono Audio SubChannels are de-embedded.

Card	SubChannels
MN-HD4I, MN-HDO-4IO, MN-HD(P)6	16
MN-Compact Video In	16
MN-C-OPT-SDI-8I, MN-C-OPT-SDI-4I4O	16
MN-C-OPT-HDMI-4I, MN-C-OPT-HDMI-2I2O	2

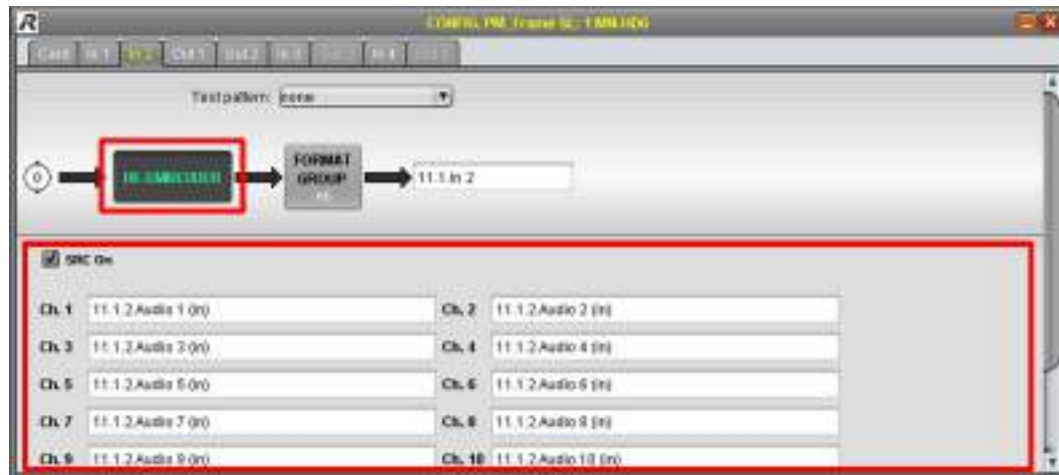

Figure 227: De-Embedder of MN-HD6

SRC On	By checking the box <i>SRC On</i> , the sample rate converter will synchronize the asynchronous Audio SubChannels to the MediorNet clock.
Ch. x	The single Audio SubChannels can be named individually.

USO RESTRITTO

▼ EMBEDDER

The Embedder is available on Video output Cards.

Each 4 Audio SubChannels are combined in one group (2 AES3 streams or 4 mono AES-SubChannels). Depending on the media Card, the Embedder includes up to 16 mono AES-channels in a SDI Video stream.

Card	SubChannels	Groups
MN-HD40, MN-HD0-4IO, MN-HD(P)6	16	4
MN-Compact Video Out	16	4
MN-C-OPT-SDI-80, MN-C-OPT-SDI-4I4O	16	4
MN-C-OPT-HDMI-40, MN-C-OPT-HDMI-2I2O	8	2

Only a complete group can be embedded by checking the respective checkbox *embed*. No Audio data is embedded if none of the checkboxes are checked.

The 1kHz test signal, the Audio delay (max. 1000ms) and the mute function can be enabled separately on every SubChannel.



The values of the field Delay can be changed either by up & down arrow-cursor-keys or by the mouse-wheel:
 Mouse-wheel or arrow-cursor key only: 1 step, with pressed *ALT*-key: 10 steps, with pressed *SHIFT*-key: 100 steps.

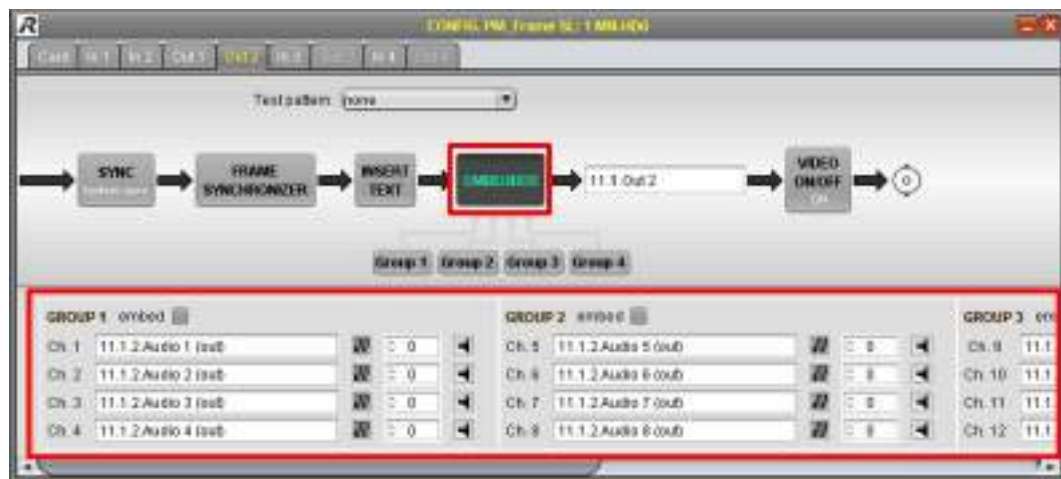

Figure 228: Embedder of MN-HD6

USO RESTRITTO

5.7.7.28 Format Group

Determination of required bandwidth of respective Channel.
See also chapter [Supported Formats](#).

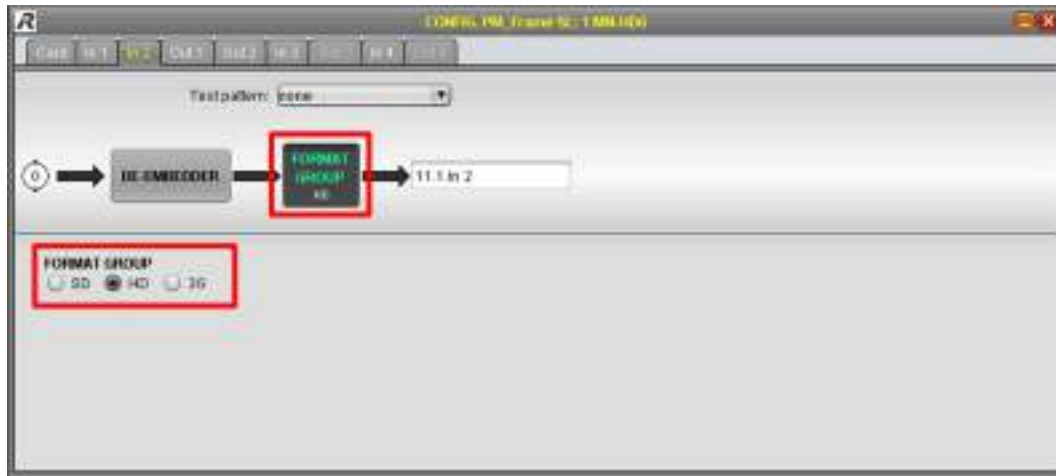

Figure 229: MN-HD6 FORMAT GROUP CONFIGURATION

Format Group	Data Rate [Mbit/s]	Timeslots (TS)
SD	270	45
HD	1485	235
3G	2970	467

USO RESTRITTO

5.7.7.29 Frame Synchronizer

The FRAME SYNCHRONIZER is available on Video output Cards.

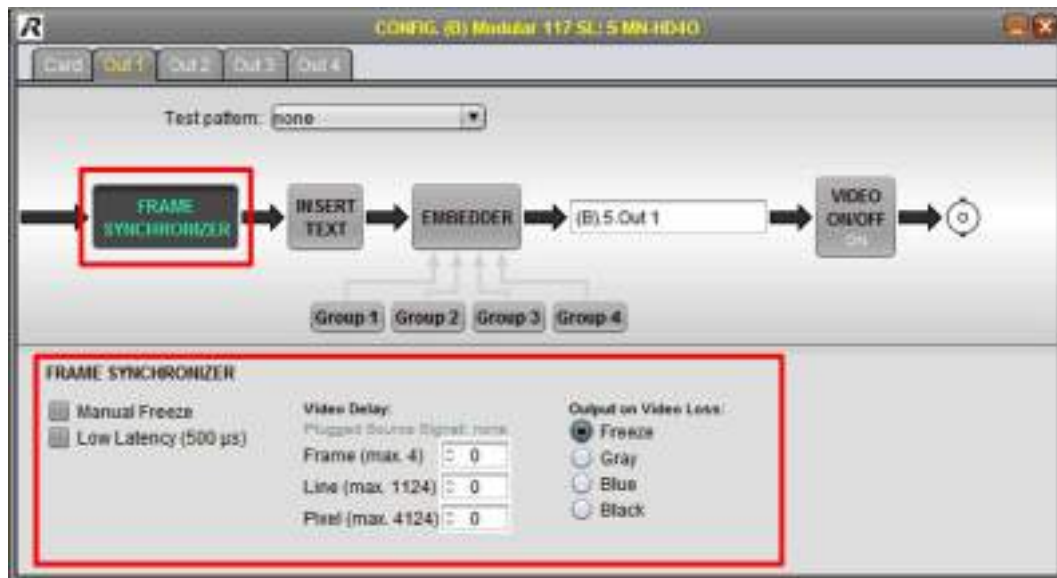

#

Figure 230: MN-HD40 FRAME SYNCHRONIZER CONFIGURATION

Manual Freeze	Video output signal will be freeze.
Low Latency (500µs)	In Low-Latency mode the Video signal has a latency of 500µs. The input signal needs to be in phase with the clock of the Video input.
Video Delay	Adjustment of the Video delay. The maximum value depends on the input signal (see table below: Video Delay).
Output on Video Loss	Selection of output signal in case of signal loss: Last valid Frame, gray screen, blue screen, black screen.

The values of the fields Frame, Line and Pixel can be changed either by up & down arrow-cursor-keys or by the mouse-wheel: Mouse-wheel or arrow-cursor key only: 1 step, with pressed *ALT*-key: 10 steps, with pressed *SHIFT*-key: 100 steps.

USO RESTRITTO

Video Delay

Format	max delay of Frames	max delay of Lines	max delay of Pixel
default	5	1125	4125
525i59.94	5	525	858
625i50	5	625	864
720p60	3	750	1650
720p59.94	3	750	1650
720p50	3	750	1980
720p30	1	750	3300
720p29.97	1	750	3300
720p25	1	750	3960
720p24	1	750	4125
720p23.98	1	750	4125
1080i60	1	1125	2200
1080i59.94	1	1125	2200
1080i50	1	1125	2640
1080p60	1	1125	2200
1080p59.94	1	1125	2200
1080p50	1	1125	2640
1080p30	1	1125	2200
1080p29.97	1	1125	2200
1080p25	1	1125	2640
1080p24	1	1125	2750
1080p23.98	1	1125	2750

USO RESTRITTO

5.7.7.30 Insert Text

This function overlays status information on the respective output signal.

These settings are available on all Video out Channels (exceptions are: Grass Valley, HDP6 QuadSplit-Channel and Conversion-Channel).

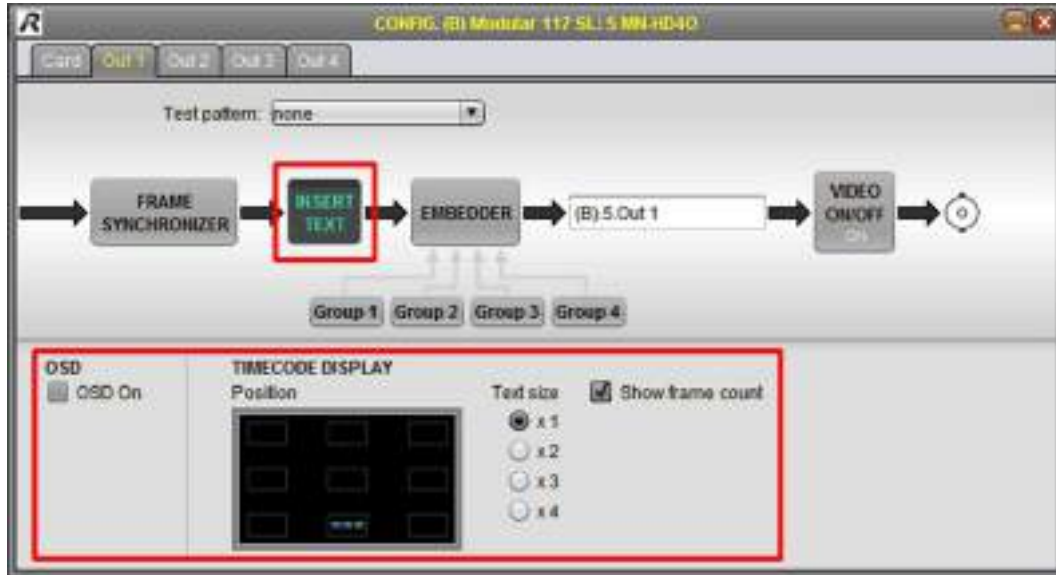

Figure 231: MN-HD40 INSERT TEXT CONFIGURATION

OSD On	Enable / disable of the On-Screen Display (see chapter OSD On-Screen Display).
Position	9 small, gray boxes in the big black box offers the 9 positions of the timecode on the screen. Clicking on one position selects or disables the display.
Text size	Selection of the text size of the timecode.
Show frame count	Enable / disable of the display of the Video frames behind the seconds (hh : mm : ss : Video Frames).

USO RESTRITTO

5.7.8 STATUS - window

By right-click on a Frame, Card, Channel or SubChannel a context menu opens. The option "Status" will open the same named window. It can be opened in the [DEVICE BROWSER](#) as well as in the [MATRIX](#). Depending on clicking on a Frame, Card, Channel or SubChannel, different contents are displayed in the STATUS-window described in the following chapters.

STATUS windows are automatically re-opened, if they were open while closing MediorWorks.

5.7.8.1 MN-Modular Frame STATUS

In the headline is the name of the Frame shown.



Figure 232: MN-Modular Frame STATUS

The meanings of the different fields are described in the table below:

Name	Detailed Name of the Frame
Short Name	Short name of the Frame
Type	Type of the Frame
Node ID	Frame (Node) identifier
IP Address	IP address of the Frame
Package Version	Version number of the software package
Firmware Version	Version number of the firmware (included in the software package)
Backplane Version	Version number of the backplane (mounted in the Frame)
GUID	Globally Unique Identifier
Riedel Serial	Riedel serial number of the Frame
Production Date	Date and time of production
Service Date	Date and time of last service
Fan Speed	RPM of the fan
Temperature	Temperature of FPGA on this Card
PSU 1 / PSU 2	PSUs status indications

USO RESTRITO

5.7.8.2 MN-XSS STATUS

In the headline is the name of the Frame, the name of the MN-XSS as well as the slot shown.

▼ MN-XSS Card STATUS



Figure 233: MN-XSS Card STATUS

The meanings of the different fields are described in the table below:

Name	Name of the Card
Type	Type of Card
Frame Name	Name of the Frame
Slot	Slot number
Temperature	Temperature of FPGA on this Card
FPGA Version	Version number of the FPGA
Hardware Version	Version number of the hardware
Firmware Version	Version number of the firmware (included in the software package)
Card Serial	Serial number of this Card
Riedel Serial	Riedel serial number of the Card
Production Date	Date and time of production
Service Date	Date and time of last service

USO RESTRITTO

▼ MN-XSS Artist STATUS

The contents in the tab *Artist 1 (RJ45)* and *Artist 2 (BNC)* are identical.

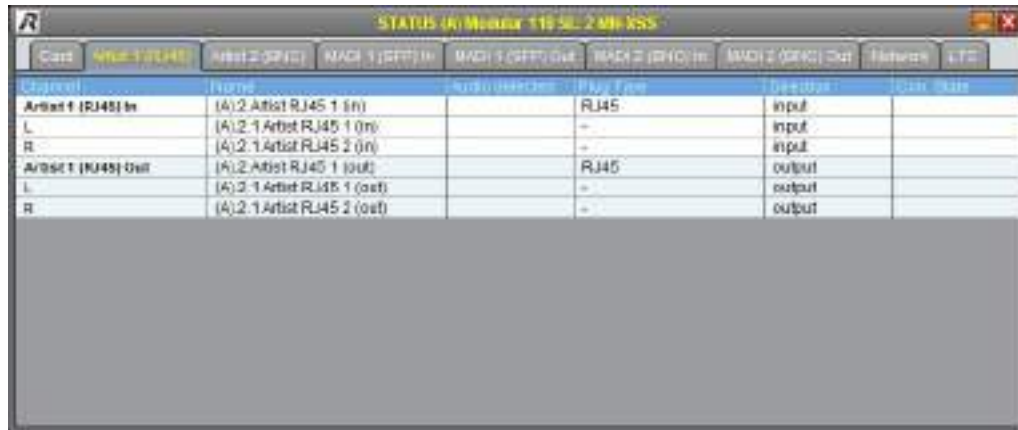

Figure 234: MN-XSS Artist STATUS

The meanings of the different fields are described in the table below:

Channel	Identifier for the AES Channel / single Audio SubChannels
Name	Name of the AES Channel / single Audio SubChannels
Audio detected	detected Audio signal
Plug Type	Type of physical connector
Direction	Signal direction: In- / Output
Connection State	Icon about state of connection

USO RESTRITO

▼ MN-XSS MADI 1 (SFP) STATUS

The contents in the tab *MADI 1 In (SFP)* and *MADI 1 Out (SFP)* are identical.

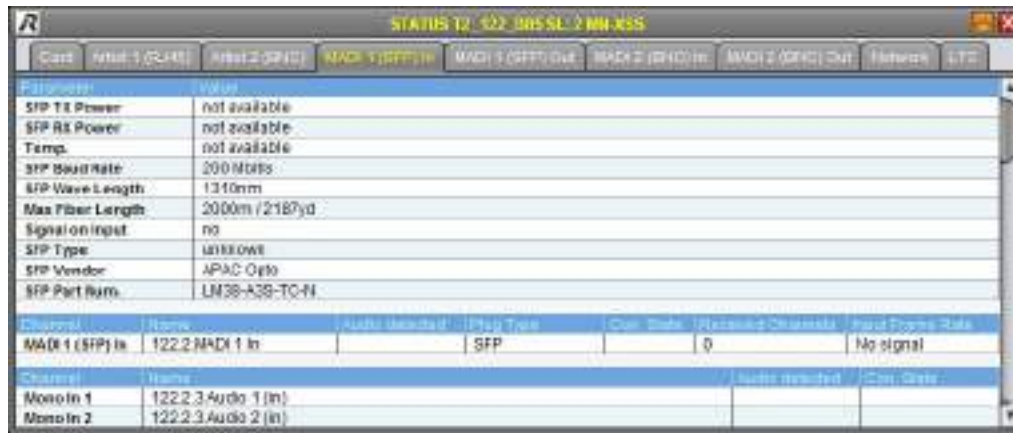

Figure 235: MN-XSS MADI 1 (SFP) STATUS

The meanings of the different fields are described in the table below:

SFP TX Power	optical output power
SFP RX Power	optical input power
Temp.	Temperature of the SFP-Module
SFP Baud Rate	optical transmission rate
SFP Wave Length	Wavelength of SFP transceiver
Max Fiber Length	Maximum distance of the SFP-Module
Signal on Input	Input signal present: yes / no
SFP Type	Type of the plugged SFP-Module
SFP Vendor	Vendor of the SFP transceiver
SFP Part Num.	Part number of SFP
Channel	Identifier for the MADI Channel / the single Audio SubChannels
Name	Name of the MADI Channel / the single Audio SubChannels
Audio detected	detected MADI signal
Plug Type	Type of physical connector
Con. State	Icon about state of connection
Received Channels *	Quantity of received channels
Input Frame Rate *	Sample rate of received MADI stream

* only in tab *MADI 1 In (SFP)*

USO RESTRITO

▼ MN-XSS MADI 2 (BNC) STATUS

The contents in the tab *MADI 2 In (BNC)* and *MADI 2 Out (BNC)* are identical.

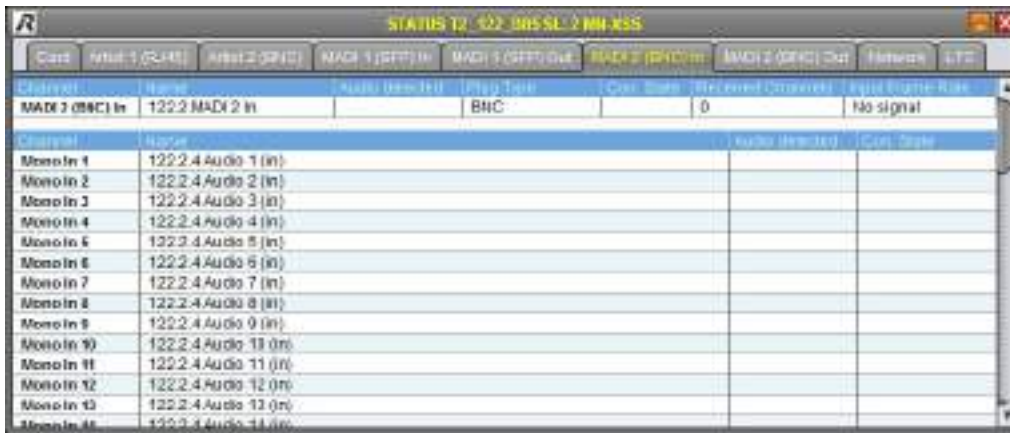

Figure 236: MN-XSS MADI 2 (BNC) STATUS

The meanings of the different fields are described in the table below:

Channel	Identifier for the MADI Channel / the single Audio SubChannels
Name	Name of the MADI Channel / the single Audio SubChannels
Audio detected	detected MADI signal
Plug Type	Type of physical connector
Con. State	Icon about state of connection
Received Channels *	Quantity of received channels
Input Frame Rate *	Sample rate of received MADI stream

* only in tab *MADI 2 In (BNC)*

USO RESTRITO

▼ MN-XSS Network STATUS



Figure 237: MN-XSS Network STATUS

The meanings of the different fields are described in the table below:

Channel	Signal type and Channel number
Name	Name of the Signal
Link Status	State of the Link (with bandwidth information)
Con. State	Icon about state of connection
Plug Type	Type of physical connector

▼ MN-XSS LTC STATUS



Figure 238: MN-XSS LTC STATUS

The meanings of the different fields are described in the table below:

Channel	Signal type and Channel number
Name	Name of the Timecode signal
LTC detected	State of the Timecode
Con. State	Icon about state of connection

USO RESTRITTO

5.7.8.3 MN-HD4I STATUS

In the headline is the name of the Frame, the name of the MN-HD4I as well as the slot shown.

▼ MN-HD4I Card STATUS



Figure 239: MN-HD4I Card STATUS

The meanings of the different fields are described in the table below:

Name	Name of the Card
Type	Type of Card
Frame Name	Name of the Frame
Slot	Slot number
Temperature	Temperature of FPGA on this Card
FPGA Version	Version number of the FPGA
Hardware Version	Version number of the hardware
Firmware Version	Version number of the firmware (included in the software package)
Card Serial	Serial number of this Card
Riedel Serial	Riedel serial number of the Card
Production Date	Date and time of production
Service Date	Date and time of last service

USO RESTRITTO

▼ MN-HD4I In STATUS

The contents in the tab *In 1* to *In 4* are identical.



Figure 240: MN-HD4I In STATUS

The meanings of the different fields are described in the table below:

Name	Name of the Channel
Input Signal	Signal type of the input
Plug Type	Type of physical connector
Test Signal	Signal format of the Test Pattern
Connection State	Icon about state of connection

USO RESTRITTO

5.7.8.4 MN-HD40 STATUS

In the headline is the name of the Frame, the name of the MN-HD40 as well as the slot shown.

▼ MN-HD-40 Card STATUS

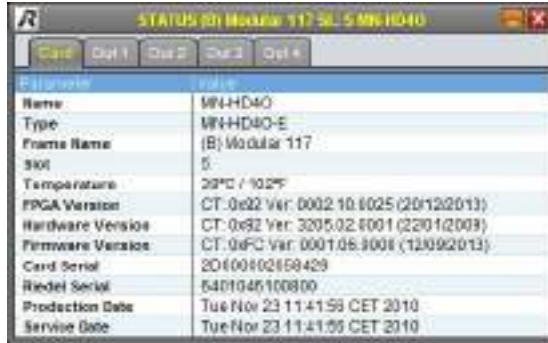

Figure 241: MN-HD40 Card STATUS

The meanings of the different fields are described in the table below:

Name	Name of the Card
Type	Type of Card
Frame Name	Name of the Frame
Slot	Slot number
Temperature	Temperature of FPGA on this Card
FPGA Version	Version number of the FPGA
Hardware Version	Version number of the hardware
Firmware Version	Version number of the firmware (included in the software package)
Card Serial	Serial number of this Card
Riedel Serial	Riedel serial number of the Card
Production Date	Date and time of production
Service Date	Date and time of last service

USO RESTRITTO

▼ MN-HD-4O Out STATUS

The contents in the tab *Out 1* to *Out 4* are identical.



Figure 242: MN-HD4O Out STATUS

The meanings of the different fields are described in the table below:

Name	Name of the Channel
Connected Signal	Signal type of the input, which is routed to this output
Plug Type	Type of physical connector
Output Signal	Signal type of the output
Connection State	Icon about state of connection

USO RESTRITTO

5.7.8.5 MN-HDO-4IO STATUS

In the headline is the name of the Frame, the name of the MN-HDO-4IO as well as the slot shown.

▼ MN-HDO-4IO Card STATUS



Figure 243: MN-HDO-4IO Card STATUS

The meanings of the different fields are described in the table below:

Name	Name of the Card
Type	Type of Card
Frame Name	Name of the Frame
Slot	Slot number
Temperature	Temperature of FPGA on this Card
FPGA Version	Version number of the FPGA
Hardware Version	Version number of the hardware
Firmware Version	Version number of the firmware (included in the software package)
Card Serial	Serial number of this Card
Riedel Serial	Riedel serial number of the Card
Production Date	Date and time of production
Service Date	Date and time of last service

USO RESTRITO

▼ MN-HDO-4IO In STATUS

The contents in the tab *In 1* to *In 4* are identical.



Figure 244: MN-HDO-4IO In STATUS

The meanings of the different fields are described in the table below:

Name	Name of the Channel
Input Signal	Signal type of the input
Plug Type	Type of physical connector
Test Signal	Signal format of the Test Pattern
Connection State	Icon about state of connection
SFP Type	Type of plugged SFP module
SFP Vendor	Vendor of SFP
SFP Part Number	Part number of SFP

USO RESTRITTO

▼ MN-HDO-4IO Out STATUS

The contents in the tab *Out 1* to *Out 4* are identical.



Figure 245: MN-HDO-4IO Out STATUS

The meanings of the different fields are described in the table below:

Name	Name of the Channel
Connected Signal	Signal type of the input, which is routed to this output
Plug Type	Type of physical connector
Output Signal	Signal type of the output
Connection State	Icon about state of connection
SFP Type	Type of plugged SFP module
SFP Vendor	Vendor of SFP
SFP Part Num.	Part number of SFP

USO RESTRITTO

5.7.8.6 MN-HD6 STATUS

In the headline is the name of the Frame, the name of the MN-HD6 as well as the slot shown.

▼ MN-HD6 Card STATUS



Figure 246: MN-HD6 Card STATUS

The meanings of the different fields are described in the table below:

Name	Name of the Card
Type	Type of Card
Frame Name	Name of the Frame
Slot	Slot number
Temperature	Temperature of FPGA on this Card
FPGA Version	Version number of the FPGA
Hardware Version	Version number of the hardware
Firmware Version	Version number of the firmware (included in the software package)
Card Serial	Serial number of this Card
Riedel Serial	Riedel serial number of the Card
Production Date	Date and time of production
Service Date	Date and time of last service

▼ MN-HD6 In STATUS

The contents in the tab *In 1* to *In 4* are identical.



Figure 247: MN-HD6 In STATUS

The meanings of the different fields are described in the table below:

Name	Name of the Channel
Input Signal	Signal type of the input
Plug Type	Type of physical connector
Test Signal	Signal format of the Test Pattern
Connection State	Icon about state of connection

USO RESTRITTO

▼ MN-HD6 Out STATUS

The contents in the tab *Out 1* to *Out 4* are identical.



Figure 248: MN-HD6 Out STATUS

The meanings of the different fields are described in the table below:

Name	Name of the Channel
Connected Signal	Signal type of the input, which is routed to this output
Plug Type	Type of physical connector
Output Signal	Signal type of the output
Connection State	Icon about state of connection

USO RESTRITTO

5.7.8.7 MN-HDP6 STATUS

In the headline is the name of the Frame, the name of the MN-HDP6 as well as the slot shown.

▼ MN-HDP6 Card STATUS

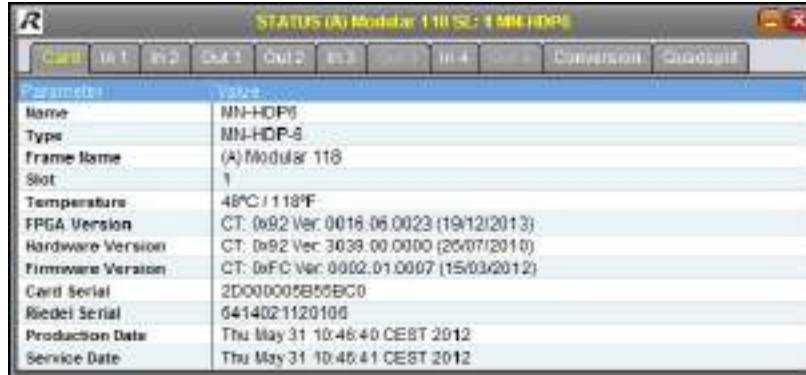

Figure 249: MN-HDP6 Card STATUS

The meanings of the different fields are described in the table below:

Name	Name of the Card
Type	Type of Card
Frame Name	Name of the Frame
Slot	Slot number
Temperature	Temperature of FPGA on this Card
FPGA Version	Version number of the FPGA
Hardware Version	Version number of the hardware
Firmware Version	Version number of the firmware (included in the software package)
Card Serial	Serial number of this Card
Riedel Serial	Riedel serial number of the Card
Production Date	Date and time of production
Service Date	Date and time of last service

USO RESTRITTO

▼ MN-HDP6 In STATUS

The contents in the tab *In 1* to *In 4* are identical.



Figure 250: MN-HDP6 In STATUS

The meanings of the different fields are described in the table below:

Name	Name of the Channel
Input Signal	Signal type of the input
Plug Type	Type of physical connector
Test Signal	Signal format of the Test Pattern
Connection State	Icon about state of connection

USO RESTRITTO

▼ MN-HDP6 Out STATUS

The contents in the tab *Out 1* to *Out 4* are identical.

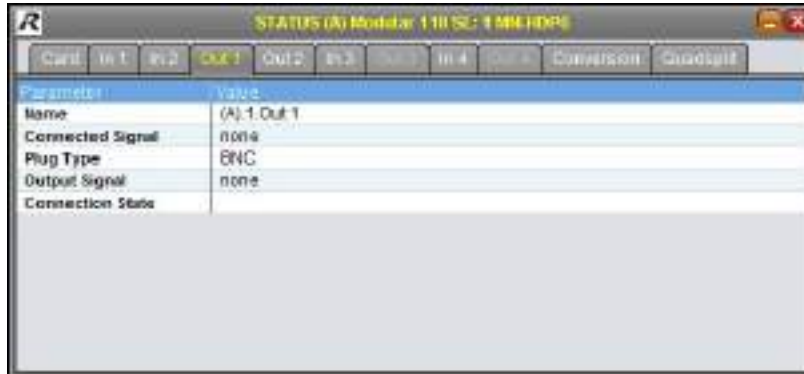

Figure 251: MN-HDP6 Out STATUS

The meanings of the different fields are described in the table below:

Name	Name of the Channel
Connected Signal	Signal type of the input, which is routed to this output
Plug Type	Type of physical connector
Output Signal	Signal type of the output
Connection State	Icon about state of connection

USO RESTRITTO

▼ MN-HDP6 Conversion STATUS

Channel	Name	Input Signal	Con. State
Conversion 1 In	(A) 1 Conversion In 1	none	
Conversion 2 In	(A) 1 Conversion In 2	none	

Channel	Name	Output Signal	Con. State
Conversion 1 Out	(A) 1 Conversion Out 1	none	
Conversion 2 Out	(A) 1 Conversion Out 2	none	

Figure 252: MN-HDP6 Conversion STATUS

The meanings of the different fields are described in the table below:

Channel	Number of the Conversion-Channel
Name	Name of the Channel
Input Signal	Signal format of the input
Output Signal	Signal format of the output
Con. State	Icon about state of connection

USO RESTRITO

▼ MN-HDP6 Quadsplit STATUS

Channel	Name	Input Signal	Con. State
Quadsplit In 1	(A) 1 Quadsplit In 1	none	
Quadsplit In 2	(A) 1 Quadsplit In 2	none	
Quadsplit In 3	(A) 1 Quadsplit In 3	none	
Quadsplit In 4	(A) 1 Quadsplit In 4	none	
Channel	Name	Output Signal	Con. State
Quadsplit Out	(A) 1 Quadsplit Out	HD 1080i 59.94 Hz	

Figure 253: MN-HDP6 Quadsplit STATUS

The meanings of the different fields are described in the table below:

Channel	Number of the Conversion-Channel
Name	Name of the Channel
Input Signal	Signal format of the input
Output Signal	Signal format of the output
Con. State	Icon about state of connection

USO RESTRITTO

5.7.8.8 MN-MA2EO STATUS

In the headline is the name of the Frame, the name of the MN-MA2EO as well as the slot shown.

▼ MN-MA2EO Card STATUS



Figure 254: MN-MA2EO Card STATUS

The meanings of the different fields are described in the table below:

Name	Name of the Card
Type	Type of Card
Frame Name	Name of the Frame
Slot	Slot number
Temperature	Temperature of FPGA on this Card
FPGA Version	Version number of the FPGA
Hardware Version	Version number of the hardware
Firmware Version	Version number of the firmware (included in the software package)
Card Serial	Serial number of this Card
Riedel Serial	Riedel serial number of the Card
Production Date	Date and time of production
Service Date	Date and time of last service

USO RESTRITO

▼ MN-MA2EO MADI 1 (BNC) STATUS

The contents in the tab *MADI 1 In (BNC)* and *MADI 1 Out (BNC)* are identical.



Figure 255: MN-MA2EO MADI 1 (BNC) STATUS

The meanings of the different fields are described in the table below:

Channel	Identifier for the MADI Channel / the single Audio SubChannels
Name	Name of the MADI Channel / the single Audio SubChannels
Audio detected	detected MADI signal
Plug Type	Type of physical connector
Con. State	Icon about state of connection
Received Channels *	Quantity of received channels
Input Frame Rate *	Sample rate of received MADI stream

* only in tab *MADI 1 (BNC) In*

USO RESTRITTO

▼ MN-MA2EO MADI 2 (SFP) STATUS

The contents in the tab *MADI 2 In (SFP)* and *MADI 2 Out (SFP)* are identical.

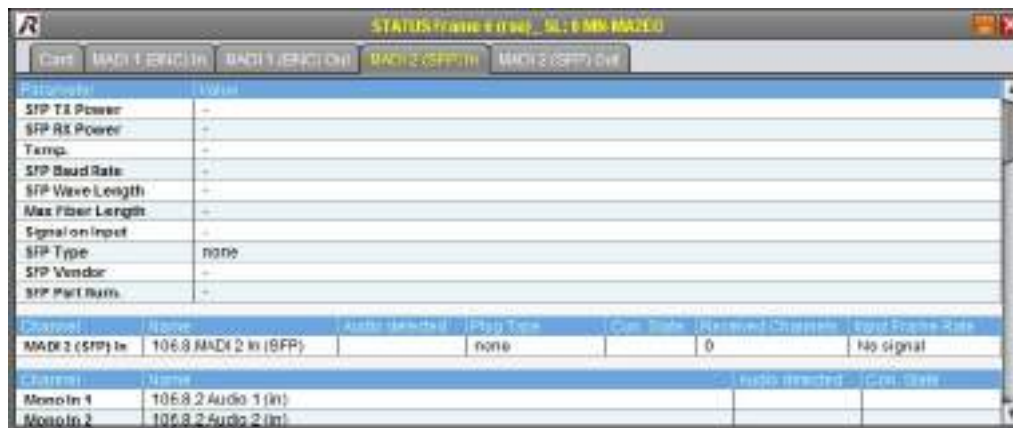

Figure 256: MN-MA2EO MADI 2 (SFP) STATUS

The meanings of the different fields are described in the table below:

SFP TX Power	optical output power
SFP RX Power	optical input power
Temp.	Temperature of the SFP-Module
SFP Baud Rate	optical transmission rate
SFP Wave Length	Wavelength of SFP transceiver
Max Fiber Length	Maximum distance of the SFP-Module
Signal on Input	Input signal present: yes / no
SFP Type	Type of the plugged SFP-Module
SFP Vendor	Vendor of the SFP transceiver
SFP Part Num.	Part number of SFP
Channel	Identifier for the MADI Channel / the single Audio SubChannels
Name	Name of the MADI Channel / the single Audio SubChannels
Audio detected	detected MADI signal
Plug Type	Type of physical connector
Con. State	Icon about state of connection
Received Channels *	Quantity of received channels
Input Frame Rate *	Sample rate of received MADI stream

* only in tab *MADI 2 (SFP) In*

USO RESTRITTO

5.7.8.9 MN-RN300 STATUS

In the headline is the name of the Frame, the name of the MN-RN300 as well as the slot shown.

▼ MN-RN300 Card STATUS



Figure 257: MN-RN300 Card STATUS

The meanings of the different fields are described in the table below:

Name	Name of the Card
Type	Type of Card
Frame Name	Name of the Frame
Slot	Slot number
Temperature	Temperature of FPGA on this Card
FPGA Version	Version number of the FPGA
Hardware Version	Version number of the hardware
Firmware Version	Version number of the firmware (included in the software package)
Card Serial	Serial number of this Card
Riedel Serial	Riedel serial number of the Card
Production Date	Date and time of production
Service Date	Date and time of last service

USO RESTRITO

▼ MN-RN300 MADI In STATUS

The contents in the tab *MADI 1 In* and *MADI 2 In* are identical.

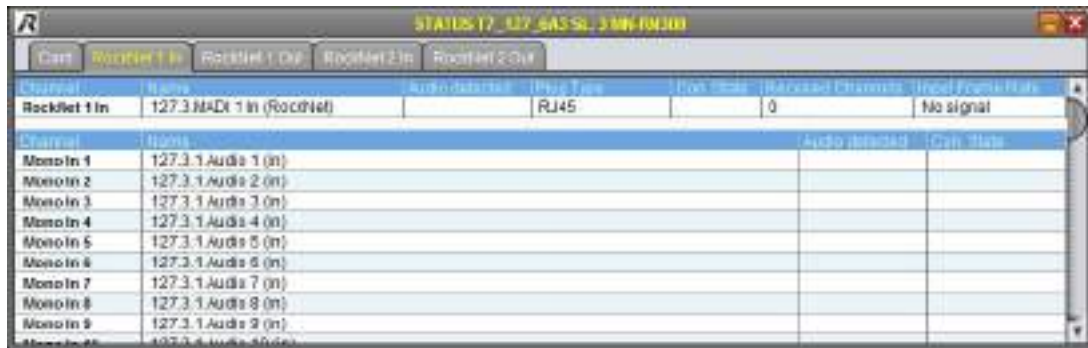

Figure 258: MN-RN300 MADI In STATUS

The meanings of the different fields are described in the table below:

Channel	Identifier for the MADI Channel / the single Audio SubChannels
Name	Name of the MADI Channel / the single Audio SubChannels
Audio detected	detected MADI signal
Plug Type	Type of physical connector
Con. State	Icon about state of connection
Received Channels	Quantity of received channels
Input Frame Rate	Sample rate of received MADI stream

USO RESTRITTO

▼ MN-RN300 MADI Out STATUS

The contents in the tab *MADI 1 Out* and *MADI 2 Out* are identical.

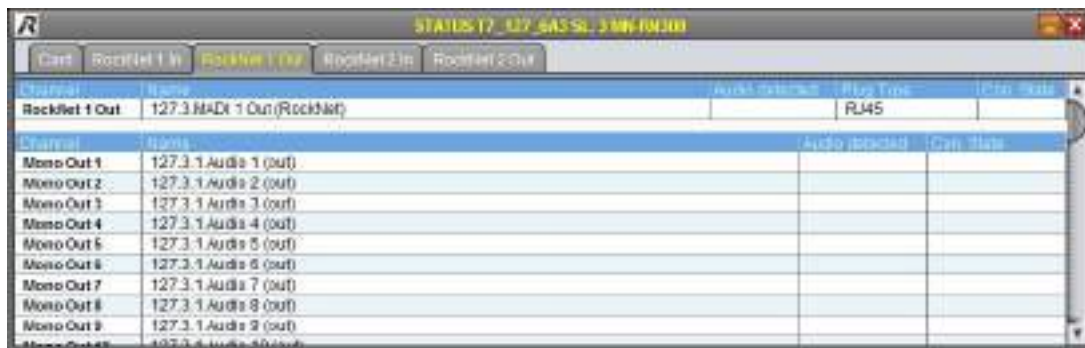

Figure 259: MN-RN300 MADI Out STATUS

The meanings of the different fields are described in the table below:

Channel	Identifier for the MADI Channel / the single Audio SubChannels
Name	Name of the MADI Channel / the single Audio SubChannels
Audio detected	detected MADI signal
Plug Type	Type of physical connector
Con. State	Icon about state of connection

USO RESTRITTO

5.7.8.10 MN-MIO STATUS

In the headline is the name of the Frame, the name of the MN-MIO as well as the slot shown.

▼ MN-MIO Card STATUS



Figure 260: MN-MIO Card STATUS

The meanings of the different fields are described in the table below:

Name	Name of the Card
Type	Type of Card
Frame Name	Name of the Frame
Slot	Slot number
Temperature	Temperature of FPGA on this Card
FPGA Version	Version number of the FPGA
Hardware Version	Version number of the hardware
Firmware Version	Version number of the firmware (included in the software package)
Card Serial	Serial number of this Card
Riedel Serial	Riedel serial number of the Card
Production Date	Date and time of production
Service Date	Date and time of last service

USO RESTRITTO

▼ MN-MIO Analog STATUS

The contents in the tab *Analog In* and *Analog Out* are identical.



Figure 261: MN-MIO Analog STATUS

The meanings of the different fields are described in the table below:

Channel	Identifier for the analog Audio Channel
Name	Name of the analog Audio Channel
Audio detected	Detected Audio signal
Plug Type	Type of physical connector

USO RESTRITO

▼ MN-MIO AES STATUS

The contents in the tab *AES In* and *AES Out* are identical.



Channel	Name	Audio detected	Plug Type
AES 1	119.8.AES3 1 (in)		RJ45
L	119.8.1 Audio 1 (in)	-	-
R	119.8.1 Audio 2 (in)	-	-
AES 2	119.8.AES3 2 (in)		RJ45
L	119.8.2 Audio 1 (in)	-	-
R	119.8.2 Audio 2 (in)	-	-
AES 3	119.8.AES3 3 (in)		RJ45
L	119.8.3 Audio 1 (in)	-	-
R	119.8.3 Audio 2 (in)	-	-
AES 4	119.8.AES3 4 (in)		RJ45
L	119.8.4 Audio 1 (in)	-	-
R	119.8.4 Audio 2 (in)	-	-

Figure 262: MN-MIO AES STATUS

The meanings of the different fields are described in the table below:

Channel	Identifier for the AES (Sub)Channel (AES/left/right)
Name	Name of the AES (Sub)Channel (AES/left/right)
Audio detected	Detected Audio signal
Plug Type	Type of physical connector

USO RESTRITTO

▼ MN-MIO Serial STATUS



Figure 263: MN-MIO Serial STATUS

The meanings of the different fields are described in the table below:

Channel	Channel number
Name	Name of Channel
Plug Type	Type of physical connector
Mode	actual mode: In/Out or Bidirectional

USO RESTRITTO

▼ MN-MIO GPI STATUS

The contents in the tab *GPI In* and *GPI Out* are identical.



Channel	Name	Plug Type	State
GPI In 1	119.8.GPI 1 (In)	D-SUB	On
GPI In 2	119.8.GPI 2 (In)	D-SUB	On
GPI In 3	119.8.GPI 3 (In)	D-SUB	On
GPI In 4	119.8.GPI 4 (In)	D-SUB	On
GPI In 5	119.8.GPI 5 (In)	D-SUB	On
GPI In 6	119.8.GPI 6 (In)	D-SUB	On
GPI In 7	119.8.GPI 7 (In)	D-SUB	On
GPI In 8	119.8.GPI 8 (In)	D-SUB	On
GPI In 9	119.8.GPI 9 (In)	D-SUB	On
GPI In 10	119.8.GPI 10 (In)	D-SUB	On
GPI In 11	119.8.GPI 11 (In)	D-SUB	On
GPI In 12	119.8.GPI 12 (In)	D-SUB	On

Figure 264: MN-MIO GPI STATUS

The meanings of the different fields are described in the table below:

Channel	Channel number
Name	Name of Channel
Plug Type	Type of physical connector
State	State of the GPI Channel after selected processing mode

USO RESTRITTO

5.7.8.11 MN-LNK2,4 STATUS

In the headline is the name of the Frame, the name of the MN-LNKx as well as the slot shown.

The link Cards *LNK2* and *LNK4* contain the same structure. The only difference is the number of available ports:

MN-LNK2	2 Ports
MN-LNK4	4 Ports

▼ MN-LNK2,4 Card STATUS



Figure 265: MN-LNK2,4 Card STATUS

The meanings of the different fields are described in the table below:

Name	Name of the Card
Type	Type of Card
Frame Name	Name of the Frame
Slot	Slot number
Temperature	Temperature of this Card
Hardware Version	Version number of the hardware
Firmware Version	Version number of the firmware (included in the software package)
Card Serial	Serial number of this Card
Riedel Serial	Riedel serial number of the Card
Production Date	Date and time of production
Service Date	Date and time of last service

USO RESTRITTO

▼ MN-LNK2,4 LNK STATUS

The contents in the tabs *LNKx* are identical.

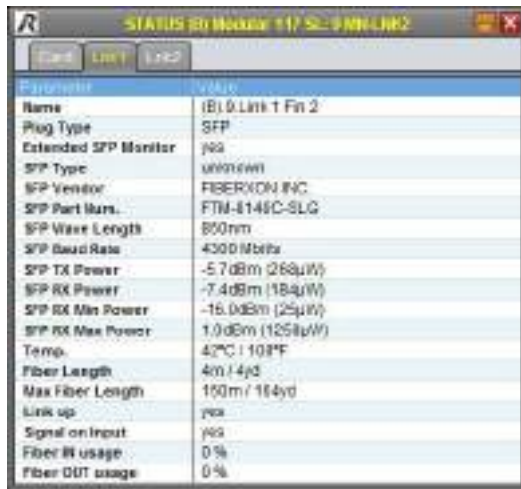

Figure 266: MN-LNK2,4 LNK STATUS

The meanings of the different fields are described in the table below:

Name	Name of the Channel
Plug Type	Type of physical connector
Extended SFP Monitor	Extended SFP information available
SFP Type	Type of the plugged SFP-Module
SFP Vendor	Vendor of the SFP
SFP Part Num.	Part Number of the SFP
SFP Wave Length	Wavelength of SFP transceiver
SFP Baud Rate	Optical transmission rate
SFP TX Power	Optical output power
SFP RX Power	Optical input power
SFP RX Min Power	Minimum input power of the SFP module
SFP RX Max Power	Maximum input power of the SFP module
Temp.	Temperature of the SFP transceiver
Fiber Length	Distance between both LINK-Cards
Max. Fiber Length	Maximum allowed distance between both LINK-Cards
Link Up	Link established: yes/no
Signal on Input	Input signal present: yes/no
Fiber IN Usage	Receiver occupancy rate of the port
Fiber OUT Usage	Transmitter occupancy rate of the port

USO RESTRITO

5.7.8.12 MN-LNK8,10,18CWDM STATUS

In the headline is the name of the Frame, the name of the MN-LNKx CWDM as well as the slot shown.

The LINK-Cards *LNK8CWDM*, *LNK10CWDM* and *LNK18CWDM* contains the same structure. The only difference is the number of High-Speed connections to the backplane:

MN-LNK8-CWDM	4 Ports
MN-LNK10-CWDM	8 Ports
MN-LNK18-CWDM	8 Ports

▼ MN-LNK8,10,18CWDM Card STATUS



Figure 267: MN-LNK8,10,18CWDM Card STATUS

The meanings of the different fields are described in the table below:

Name	Name of the Card
Type	Type of Card
Frame Name	Name of the Frame
Slot	Slot number
Temperature	Temperature of this Card
Hardware Version	Version number of the hardware
Firmware Version	Version number of the firmware (included in the software package)
Card Serial	Serial number of this Card
Riedel Serial	Riedel serial number of the Card
Production Date	Date and time of production
Service Date	Date and time of last service

USO RESTRITO

▼ MN-LNK8,10,18CWDM LNK STATUS

The contents in the tabs *LNKx* are identical.



Figure 268: MN-LNK8,10,18CWDM LNK STATUS

The meanings of the different fields are described in the table below:

Name	Name of the Channel
Plug Type	Type of physical connector
Extended SFP Monitor	Extended SFP information available
SFP Type	Type of the plugged SFP-Module
SFP Vendor	Vendor of the SFP
SFP Part Num.	Part Number of the SFP
SFP Wave Length	Wavelength of SFP transceiver
SFP Baud Rate	Optical transmission rate
SFP TX Power	Optical output power
SFP RX Power	Optical input power
SFP RX Min Power	Minimum input power of the SFP module
SFP R Max Power	Maximum input power of the SFP module
Temp.	Temperature of the SFP transceiver
Fiber Length	Distance between both LINK-Cards
Max. Fiber Length	Maximum allowed distance between both LINK-Cards
Link Up	Link established: yes/no
Signal on Input	Input signal present: yes/no
Fiber IN Usage	Receiver occupancy rate of the port
Fiber OUT Usage	Transmitter occupancy rate of the port

USO RESTRITO

5.7.8.13 MN-ETH6 STATUS

In the headline is the name of the Frame, the name of the MN-ETH6 as well as the slot shown.

▼ MN-ETH6 Card STATUS

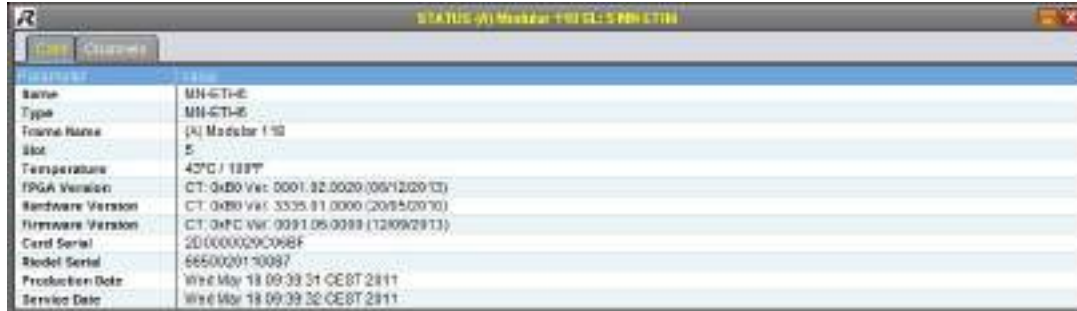

Figure 269: MN-ETH6 Card STATUS

The meanings of the different fields are described in the table below:

Name	Name of the Card
Type	Type of Card
Frame Name	Name of the Frame
Slot	Slot number
Temperature	Temperature of FPGA on this Card
FPGA Version	Version number of the FPGA
Hardware Version	Version number of the hardware
Firmware Version	Version number of the firmware (included in the software package)
Card Serial	Serial number of this Card
Riedel Serial	Riedel serial number of the Card
Production Date	Date and time of production
Service Date	Date and time of last service

USO RESTRITO

▼ MN-ETH6 Channels STATUS

Channel	Name	Link Status	Con. State	Plug Type	SFP Type	SFP Vendor	SFP Part Num.
Eth 1	(A) S-Netzwerk 1	link down		none	none	unbrwve	
Eth 2	(A) S-Netzwerk 2	link down		none	none		R812510
Eth 3	(A) S-Netzwerk 3	link down		none	none		
Eth 4	(A) S-Netzwerk 4	link down		none	none		
Eth 5	(A) S-Netzwerk 5	link down		none	none		
Eth 6	(A) S-Netzwerk 6	link down		none	none		

Figure 270: MN-ETH6 Channels STATUS

The meanings of the different fields are described in the table below:

Channel	Identifier for the Channel
Name	Name of the Channel
Link Status	State of SFP-Link (with bandwidth information)
Con. State	Icon about state of connection
Plug Type	Type of physical connector
SFP Type	Type of plugged SFP module
SFP Vendor	Vendor of SFP
SFP Part Num.	Part number of SFP

USO RESTRITO

5.7.8.14 MN-GV2 STATUS

In the headline is the name of the Frame, the name of the MN-GV2 as well as the slot shown.

▼ MN-GV-2 Card STATUS



Figure 271: MN-GV2 Card STATUS

The meanings of the different fields are described in the table below:

Name	Name of the Card
Type	Type of Card
Frame Name	Name of the Frame
Slot	Slot number
Temperature	Temperature of FPGA on this Card
FPGA Version	Version number of the FPGA
Hardware Version	Version number of the hardware
Firmware Version	Version number of the firmware (included in the software package)
Card Serial	Serial number of this Card
Riedel Serial	Riedel serial number of the Card
Production Date	Date and time of production
Service Date	Date and time of last service

USO RESTRITTO

▼ MN-GV-2 Port STATUS

The contents in the tab *Port 1* and *Port 2* are identical.



Figure 272: MN-GV2 Port STATUS

The meanings of the different fields are described in the table below:

Input Name	Name of the Input Channel
Output Name	Name of the Output Channel
Plug Type	Type of physical connector
Interface Mode	Selected Mode: Camera/Base Station
Input Signal	Input Signal present: ok/none
Output Signal	Output Signal present: ok/none
Connection State In	Icon about state of connection of Input
Connection State Out	Icon about state of connection of Output
SFP Type	Type of plugged SFP module
SFP Vendor	Vendor of SFP
SFP Part Num.	Part number of SFP

USO RESTRITTO

5.7.8.15 MN-ST-AL2 STATUS

In the headline is the name of the Frame, the name of the MN-ST-AL2 as well as the slot shown.

▼ MN-ST-AL2 Card STATUS



Figure 273: MN-ST-AL2 Card STATUS

The meanings of the different fields are described in the table below:

Name	Name of the Card
Type	Type of Card
Frame Name	Name of the Frame
Slot	Slot number
Temperature	Temperature of FPGA on this Card
FPGA Version	Version number of the FPGA
Hardware Version	Version number of the hardware
Firmware Version	Version number of the firmware (included in the software package)
Card Serial	Serial number of this Card
Riedel Serial	Riedel serial number of the Card
Production Date	Date and time of production
Service Date	Date and time of last service

USO RESTRITO

▼ MN-ST-AL2 A-Link STATUS

The contents in the tab *A-Link In 1*, *A-Link Out 1*, *A-Link In 2* and *A-Link Out 2* are identical.



Figure 274: MN-ST-AL2 A-Link STATUS

The meanings of the different fields are described in the table below:

Name	Name of the A-Link Channel / the SubChannels
Audio detected	detected A-Link Channel / SubChannel
Plug Type	Type of physical connector
Con. State	Icon about state of connection
Link Status Main SFP	State of the main link
Link Status Redundant SFP	State of the redundant link
Received Channels *	Quantity of received channels
Input Frame Rate *	Sample rate of received A-Link stream
Channel	Identifier for the Channel

* only in tabs *A-Link In x*

▼ MN-ST-AL2 SFPs STATUS



Figure 275: MN-ST-AL2 SFPs STATUS

The meanings of the different fields are described in the table below:

SFP Type	Type of plugged SFP module
SFP Vendor	Vendor of SFP
SFP Part Num.	Part number of SFP

USO RESTRITTO

5.7.8.16 MN-Compact Frame STATUS

In the headline is the name of the Frame shown.

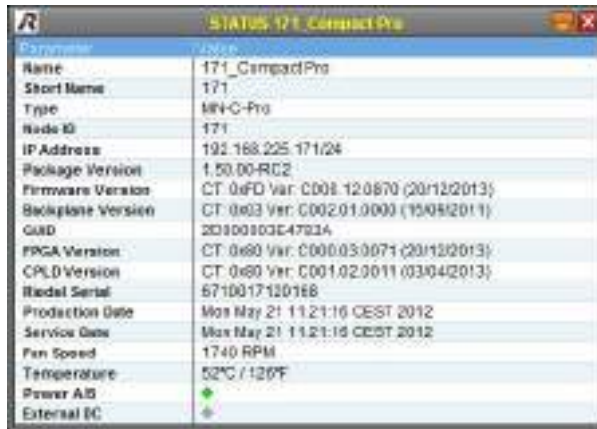

Figure 276: MN-Compact Frame STATUS

The meanings of the different fields are described in the table below:

Name	Detailed Name of the Frame
Short Name	Short Name of the Frame
Type	Type of the Frame
Node ID	Frame (Node) identifier
IP Address	IP address of the Frame
Package Version	Version number of the software package
Firmware Version	Version number of the firmware (included in the software package)
Backplane Version	Version number of the backplane (mounted in the Frame)
GUID	Globally Unique Identifier
FPGA Version	Version number of the FPGA
CPLD Version	Version number of the CPLD
Riedel Serial	Riedel serial number of the Frame
Production Date	Date and time of production
Service Date	Date and time of last service
Fan Speed	RPM of the fan
Temperature	Temperature of FPGA on this Card
Power AB / External DC	PSUs status indications

USO RESTRITO

5.7.8.17 MN-Compact Main STATUS

In the headline is the name of the Frame as well as the slot shown.

▼ MN-Compact Main Module Card STATUS



Figure 277: MN-Compact Main Module Card STATUS

The meanings of the different fields are described in the table below:

Name	Name of the Card
Type	Type of Card
Frame Name	Name of the Frame
Slot	Slot number
Hardware Version	Version number of the hardware
Riedel Serial	Riedel serial number of the Card
Production Date	Date and time of production
Service Date	Date and time of last service

▼ MN-Compact Main Module LTC STATUS

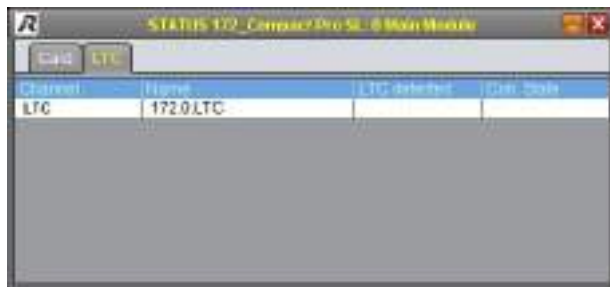

Figure 278: MN-Compact Main Module LTC STATUS

The meanings of the different fields are described in the table below:

Channel	Identifier of the Channel
Name	Name of the Channel
LTC detected	Detected Timecode
Con. State	Icon about state of connection

USO RESTRITTO

5.7.8.18 MN-Compact Video In STATUS

In the headline is the name of the Frame and the Video In Card as well as the slot shown.

▼ MN-Compact Video In Card STATUS



Figure 279: MN-Compact Video In Card STATUS

The meanings of the different fields are described in the table below:

Name	Name of the Card
Type	Type of Card
Frame Name	Name of the Frame
Slot	Slot number
Hardware Version	Version number of the hardware
Riedel Serial	Riedel serial number of the Card
Production Date	Date and time of production
Service Date	Date and time of last service

▼ MN-Compact Video In STATUS

The contents of the tabs *In 1* to *In 4* have the same structure.

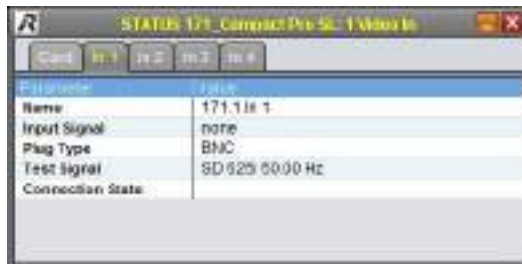

Figure 280: MN-Compact Video In STATUS

The meanings of the different fields are described in the table below:

Name	Name of the Channel
Input Signal	Signal type of the input
Plug Type	Type of physical connector
Test Signal	Signal format of the Test Pattern
Connection State	Icon about state of connection

USO RESTRITO

5.7.8.19 MN-Compact Video Out STATUS

In the headline is the name of the Frame and the Video Out Card as well as the slot shown.

▼ MN-Compact Video Out Card STATUS



Figure 281: MN-Compact Video Out Card STATUS

The meanings of the different fields are described in the table below:

Name	Name of the Card
Type	Type of Card
Frame Name	Name of the Frame
Slot	Slot number
Hardware Version	Version number of the hardware
Riedel Serial	Riedel serial number of the Card
Production Date	Date and time of production
Service Date	Date and time of last service

▼ MN-Compact Video Out STATUS

The contents of the tabs *Out 1* to *Out 4* have the same structure.

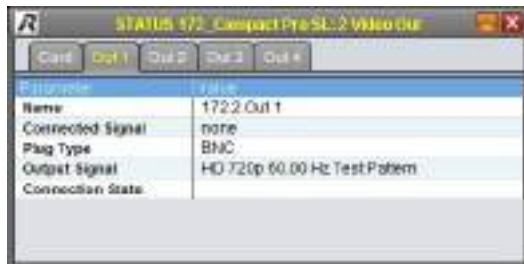

Figure 282: MN-Compact Video Out STATUS

The meanings of the different fields are described in the table below:

Name	Name of the Channel
Connected Signal	Signal type of the input, which is routed to this output
Plug Type	Type of physical connector
Output Signal	Signal type of the output
Connection State	Icon about state of connection

USO RESTRITO

5.7.8.20 MN-Compact MADI STATUS

In the headline is the name of the Frame and the MADI Card as well as the slot shown.

▼ MN-Compact MADI Card STATUS

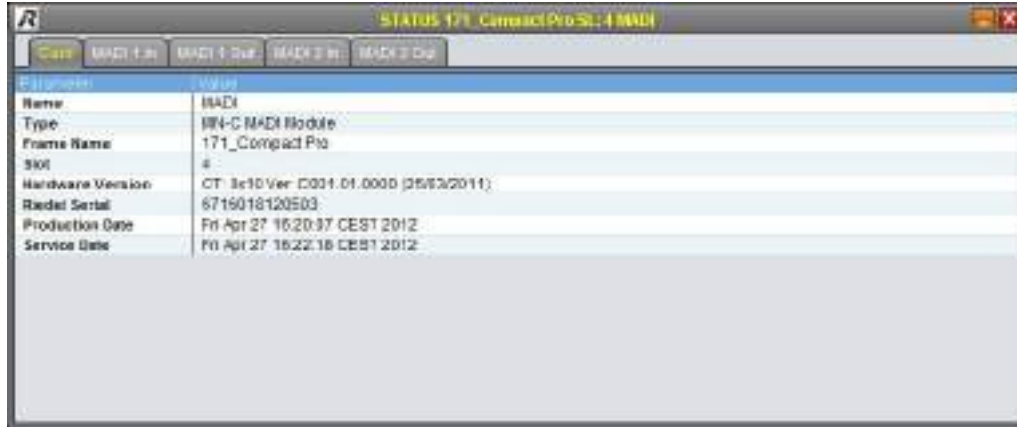

Figure 283: MN-Compact MADI Card STATUS

The meanings of the different fields are described in the table below:

Name	Name of the Card
Type	Type of Card
Frame Name	Name of the Frame
Slot	Slot number
Hardware Version	Version number of the hardware
Riedel Serial	Riedel serial number of the Card
Production Date	Date and time of production
Service Date	Date and time of last service

USO RESTRITTO

▼ MN-Compact MADI STATUS

The contents of the tabs *MADI 1 In*, *MADI 1 Out*, *MADI 2 In* and *MADI 2 Out* have the same structure.

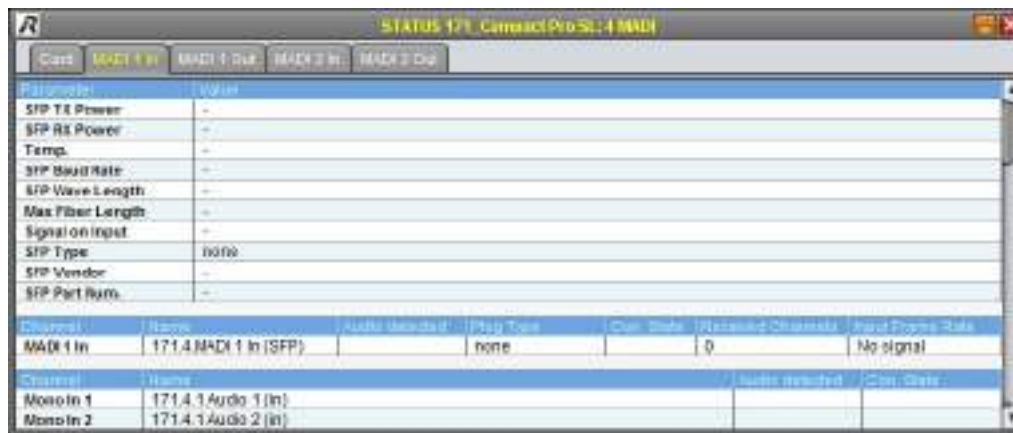

Figure 284: MN-Compact MADI STATUS

The meanings of the different fields are described in the table below:

SFP TX Power	optical output power
SFP RX Power	optical input power
Temp.	Temperature of the SFP-Module
SFP Baud Rate	optical transmission rate
SFP Wave Length	Wavelength of SFP transceiver
Max Fiber Length	Maximum distance of the SFP-Module
Signal on Input	Input signal present: yes / no
SFP Type	Type of the plugged SFP-Module
SFP Vendor	Vendor of the SFP transceiver
SFP Part Num.	Part number of SFP
Channel	Identifier for the MADI Channel / the single Audio SubChannels
Name	Name of the MADI Channel / the single Audio SubChannels
Audio detected	detected MADI signal
Plug Type	Type of physical connector
Con. State	Icon about state of connection
Received Channels *	Quantity of received channels
Input Frame Rate *	Sample rate of received MADI stream

* only in tab *MADI x In*

USO RESTRITTO

5.7.8.21 MN-Compact RockNet STATUS

In the headline is the name of the Frame and the RockNet Card as well as the slot shown.

▼ MN-Compact RockNet Card STATUS



Figure 285: MN-Compact RockNet Card STATUS

The meanings of the different fields are described in the table below:

Name	Name of the Card
Type	Type of Card
Frame Name	Name of the Frame
Slot	Slot number
Hardware Version	Version number of the hardware
Riedel Serial	Riedel serial number of the Card
Production Date	Date and time of production
Service Date	Date and time of last service

USO RESTRITO

▼ MN-Compact RockNet STATUS

The contents of the tabs *RockNet 1 In*, *RockNet 1 Out*, *RockNet 2 In* and *RockNet 2 Out* have the same structure.

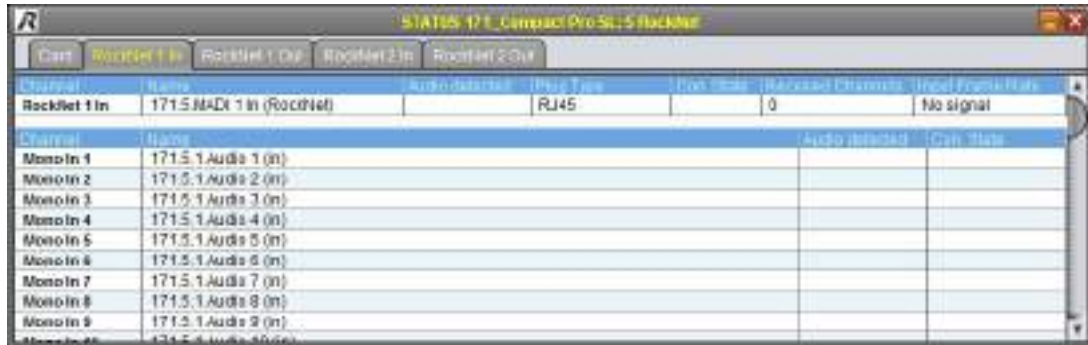

Figure 286: MN-Compact RockNet STATUS

The meanings of the different fields are described in the table below:

Channel	Identifier for the RockNet Channel / the single Audio SubChannels
Name	Name of the RockNet Channel / the single Audio SubChannels
Audio detected	detected RockNet signal
Plug Type	Type of physical connector
Con. State	Icon about state of connection
Received Channels *	Quantity of received channels
Input Frame Rate *	Sample rate of received RockNet stream

* only in tab *RockNet x In*

USO RESTRITTO

5.7.8.22 MN-Compact AES Audio STATUS

In the headline is the name of the Frame and the AES Audio Card as well as the slot shown.

▼ MN-Compact AES Audio Card STATUS



Figure 287: MN-Compact AES Audio Card STATUS

The meanings of the different fields are described in the table below:

Name	Name of the Card
Type	Type of Card
Frame Name	Name of the Frame
Slot	Slot number
Hardware Version	Version number of the hardware
Riedel Serial	Riedel serial number of the Card
Production Date	Date and time of production
Service Date	Date and time of last service

USO RESTRITTO

▼ MN-Compact AES Audio STATUS

The contents of the tabs *AES In* and *AES Out* have the same structure.

Channel	Name	Audio detected	Plug Type
AES 1	171.6.AES3 1 (in)		RJ45
L	171.6.1 Audio 1 (in)		-
R	171.6.1 Audio 2 (in)		-
AES 2	171.6.AES3 2 (in)		RJ45
L	171.6.2 Audio 1 (in)		-
R	171.6.2 Audio 2 (in)		-
AES 3	171.6.AES3 3 (in)		RJ45
L	171.6.3 Audio 1 (in)		-
R	171.6.3 Audio 2 (in)		-
AES 4	171.6.AES3 4 (in)		RJ45
L	171.6.4 Audio 1 (in)		-
R	171.6.4 Audio 2 (in)		-

Figure 288: MN-Compact AES Audio STATUS

The meanings of the different fields are described in the table below:

Channel	Identifier for the AES (Sub)Channel (AES/left/right)
Name	Name of the AES (Sub)Channel (AES/left/right)
Audio detected	Detected Audio signal
Plug Type	Type of physical connector

USO RESTRITO

5.7.8.23 MN-Compact Analog Audio STATUS

In the headline is the name of the Frame and the Analog Audio Card as well as the slot shown.

▼ MN-Compact Analog Audio Card STATUS



Figure 289: MN-Compact Analog Audio Card STATUS

The meanings of the different fields are described in the table below:

Name	Name of the Card
Type	Type of Card
Frame Name	Name of the Frame
Slot	Slot number
Hardware Version	Version number of the hardware
Riedel Serial	Riedel serial number of the Card
Production Date	Date and time of production
Service Date	Date and time of last service

▼ MN-Compact Analog Audio STATUS

The contents of the tabs *Analog In* and *Analog Out* have the same structure.

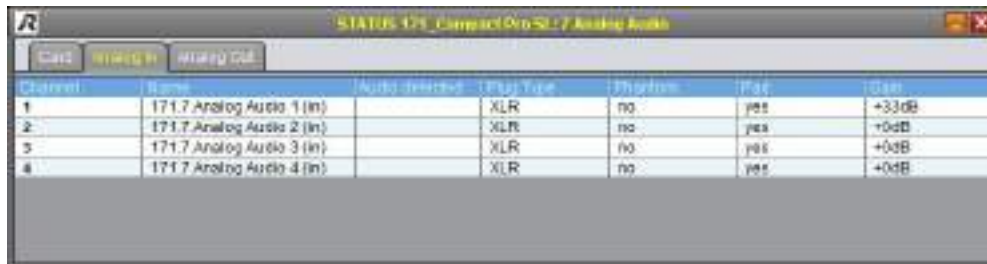

Figure 290: MN-Compact Analog Audio STATUS

The meanings of the different fields are described in the table below:

Channel	Identifier for the analog Audio Channel
Name	Name of the analog Audio Channel
Audio detected	green rhombus indicates an input signal above -30dBFS
Plug Type	Type of physical connector
Phantom *	+48V microphone Phantom Voltage on/off
Pad *	18dB signal attenuation on/off
Gain *	selected gain value

* only in tab *Analog In*

USO RESTRITO

5.7.8.24 MN-Compact Ethernet STATUS

In the headline is the name of the Frame and the Ethernet Card as well as the slot shown.

▼ MN-Compact Ethernet Card STATUS



Figure 291: MN-Compact Ethernet Card STATUS

The meanings of the different fields are described in the table below:

Name	Name of the Card
Type	Type of Card
Frame Name	Name of the Frame
Slot	Slot number
Hardware Version	Version number of the hardware
Riedel Serial	Riedel serial number of the Card
Production Date	Date and time of production
Service Date	Date and time of last service

▼ MN-Compact Ethernet STATUS

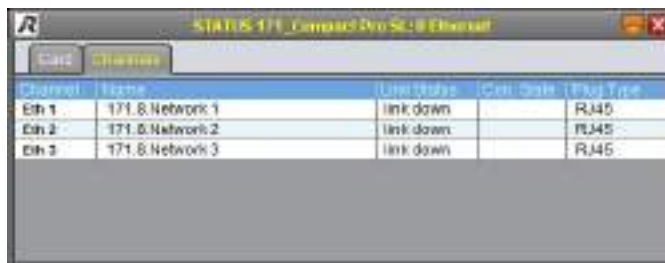

Figure 292: MN-Compact Ethernet STATUS

The meanings of the different fields are described in the table below:

Channel	Channel number
Name	Name of the Channel
Link Status	State of the Link (with bandwidth information)
Con. State	Icon about state of connection
Plug Type	Type of physical connector

USO RESTRITO

5.7.8.25 MN-Compact Serial STATUS

In the headline is the name of the Frame and the Serial Card as well as the slot shown.

▼ MN-Compact Serial Card STATUS



Figure 293: MN-Compact Serial Card STATUS

The meanings of the different fields are described in the table below:

Name	Name of the Card
Type	Type of Card
Frame Name	Name of the Frame
Slot	Slot number
Hardware Version	Version number of the hardware
Riedel Serial	Riedel serial number of the Card
Production Date	Date and time of production
Service Date	Date and time of last service

▼ MN-Compact Serial STATUS



Figure 294: MN-Compact Serial STATUS

The meanings of the different fields are described in the table below:

Channel	Channel number of the Channel
Name	Name of the Channel
Plug Type	Type of physical connector
Mode	Format of the serial Channel

USO RESTRITO

5.7.8.26 MN-Compact GPI STATUS

In the headline is the name of the Frame and the GPI Card as well as the slot shown.

▼ MN-Compact GPI Card STATUS



Figure 295: MN-Compact GPI Card STATUS

The meanings of the different fields are described in the table below:

Name	Name of the Card
Type	Type of Card
Frame Name	Name of the Frame
Slot	Slot number
Hardware Version	Version number of the hardware
Riedel Serial	Riedel serial number of the Card
Production Date	Date and time of production
Service Date	Date and time of last service

▼ MN-Compact GPI STATUS

The contents of the tabs *GPI In* and *GPI Out* have the same structure.

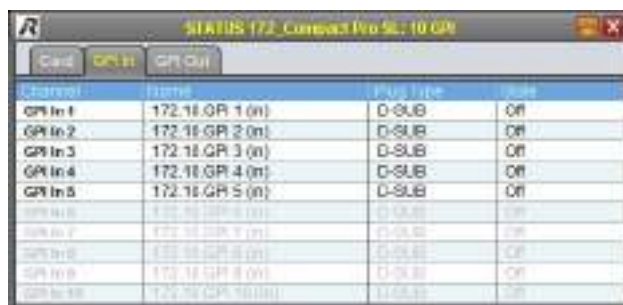

Figure 296: MN-Compact GPI STATUS

The meanings of the different fields are described in the table below:

Channel	GPI Channel number
Name	Name of the GPI Channel
Plug Type	Type of physical connector
State	State of the GPI Channel after selected processing mode

5.7.8.27 MN-Compact Link STATUS

In the headline is the name of the Frame and the LINK-Card as well as the slot shown.

▼ MN-Compact Link Card STATUS

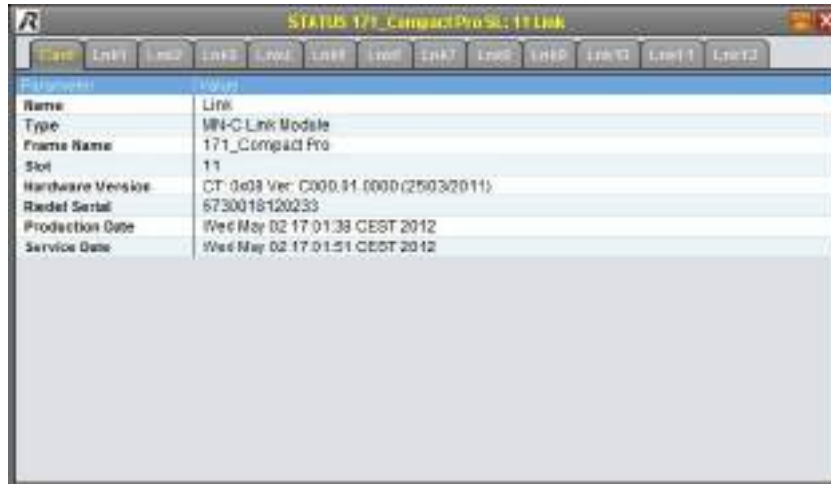

Figure 297: MN-Compact Link Card STATUS

The meanings of the different fields are described in the table below:

Name	Name of the Card
Type	Type of Card
Frame Name	Name of the Frame
Slot	Slot number
Hardware Version	Version number of the hardware
Riedel Serial	Riedel serial number of the Card
Production Date	Date and time of production
Service Date	Date and time of last service

USO RESTRITTO

▼ MN-Compact Link STATUS

The contents of the tabs *Lnk1* to *Lnk12* have the same structure.

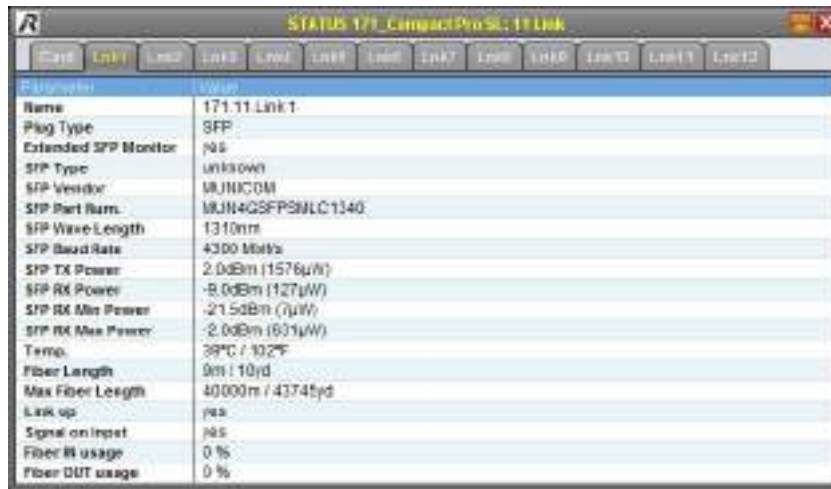

Figure 298: MN-Compact Link STATUS

The meanings of the different fields are described in the table below:

Name	Name of the Channel
Plug Type	Type of physical connector
Extended SFP Monitor	Extended SFP information available
SFP Type	Type of the plugged SFP-Module
SFP Vendor	Vendor of the SFP
SFP Part Num.	Part Number of the SFP
SFP Wave Length	Wavelength of SFP transceiver
SFP Baud Rate	Optical transmission rate
SFP TX Power	Optical output power
SFP RX Power	Optical input power
SFP RX Min Power	Minimum input power of the SFP module
SFP R Max Power	Maximum input power of the SFP module
Temp.	Temperature of the SFP transceiver
Fiber Length	Distance between both LINK-Cards
Max. Fiber Length	Maximum allowed distance between both LINK-Cards
Link Up	Link established: yes/no
Signal on Input	Input signal present: yes/no
Fiber IN Usage	Receiver occupancy rate of the port
Fiber OUT Usage	Transmitter occupancy rate of the port

USO RESTRITTO

5.7.8.28 MN-C-OPT-SDI STATUS

In the headline is the name of the Frame and the option Card as well as the slot shown.

The option Cards *SDI-8I*, *SDI-8O* and *SDI-4I4O* contain the same structure. The only difference is the number of available in-/output ports:

SDI-8I	8 input ports
SDI-8O	8 output ports
SDI-4I4O	4 input ports, 4 output ports

▼ MN-C-OPT-SDI Card STATUS



Figure 299: MN-C-OPT-SDI Card STATUS

The meanings of the different fields are described in the table below:

Name	Name of the Card
Type	Type of Card
Frame Name	Name of the Frame
Slot	Slot number
Hardware Version	Version number of the hardware
Riedel Serial	Riedel serial number of the Card
Production Date	Date and time of production
Service Date	Date and time of last service

USO RESTRITTO

▼ MN-C-OPT-SDI In STATUS

The contents of all the *In* x tabs are identical.

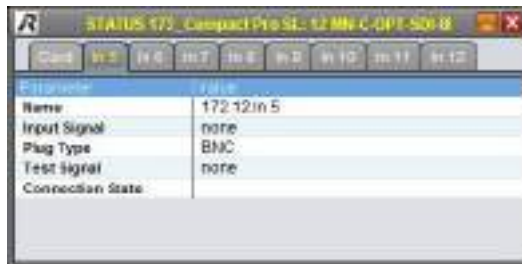

Figure 300: MN-C-OPT-SDI In STATUS

The meanings of the different fields are described in the table below:

Name	Name of the Channel
Input Signal	Signal type of the input
Plug Type	Type of physical connector
Test Signal	Signal format of the Test Pattern
Connection State	Icon about state of connection

▼ MN-C-OPT-SDI Out STATUS

The contents of all the *Out* x tabs are identical.



Figure 301: MN-C-OPT-SDI Out STATUS

The meanings of the different fields are described in the table below:

Name	Name of the Channel
Connected Signal	Signal type of the input, which is routed to this output
Plug Type	Type of physical connector
Output Signal	Signal type of the output
Connection State	Icon about state of connection

5.7.8.29 MN-C-OPT-HDMI STATUS

In the headline is the name of the Frame and the option Card as well as the slot shown.

The option Cards *HDMI-4I*, *HDMI-4O* and *HDMI-2I2O* contain the same structure. The only difference is the number of available in-/output ports:

HDMI-4I	4 input ports
HDMI-4O	4 output ports
HDMI-2I2O	2 input ports, 2 output ports

▼ MN-C-OPT-HDMI Card STATUS



Figure 302: MN-C-OPT-HDMI Card STATUS

The meanings of the different fields are described in the table below:

Name	Name of the Card
Type	Type of Card
Frame Name	Name of the Frame
Slot	Slot number
Hardware Version	Version number of the hardware
Riedel Serial	Riedel serial number of the Card
Production Date	Date and time of production
Service Date	Date and time of last service

USO RESTRITTO

▼ MN-C-OPT-HDMI In STATUS

The contents of all the *In* x tabs are identical.



Figure 303: MN-C-OPT-HDMI In STATUS

The meanings of the different fields are described in the table below:

Name	Name of the Channel
Input Signal	Signal type of the input
Plug Type	Type of physical connector
Test Signal	Signal format of the Test Pattern
Connection State	Icon about state of connection
SFP Type	Type of the plugged SFP-Module
SFP Vendor	Vendor of the SFP
SFP Part Num.	Part Number of the SFP

▼ MN-C-OPT-HDMI Out STATUS

The contents of all the *Out* x tabs are identical.



Figure 304: MN-C-OPT-HDMI Out STATUS

The meanings of the different fields are described in the table below:

Name	Name of the Channel
Connected Signal	Signal type of the input, which is routed to this output
Plug Type	Type of physical connector
Output Signal	Signal type of the output
Connection State	Icon about state of connection
SFP Type	Type of the plugged SFP-Module
SFP Vendor	Vendor of the SFP
SFP Part Num.	Part Number of the SFP

5.7.9 CONNECTION OVERVIEW - window

By right-click on a Frame in the DEVICE BROWSER or in the Parameter window and selecting the “Show Connection Overview” option in the context menu, the CONNECTION OVERVIEW window is opened.

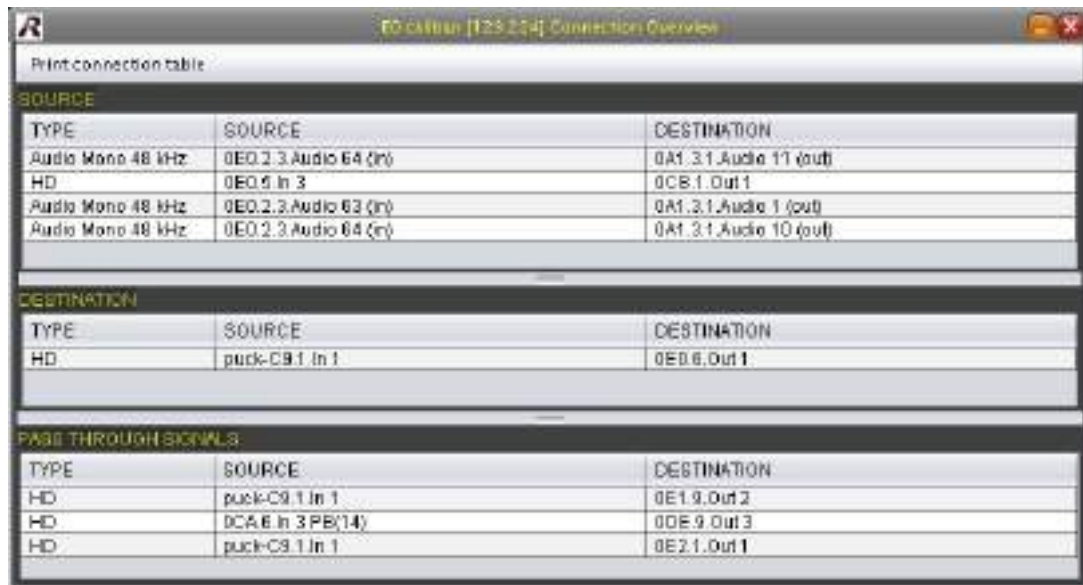

Figure 305: Connection Overview

This window contains three sections. On the top is the *SOURCE* region. Here are displayed all source signals of the Frame, on which this window was opened.

In the middle is the *DESTINATION* region. Here are displayed all destination signals of the Frame, on which this window was opened.

On the bottom is the region of *PASS THROUGH SIGNALS*. Here are displayed all signals, which are looped through the Frame, on which this window was opened.

For instance, if a signal is transferred from Frame A via Frame B to Frame C. Frame B would be the Frame which will be displayed in the region *PASS THROUGH SIGNALS*.

With the function *Print connection table* in the menu bar, the user is able to print out a table of the signals in the single regions.

USO RESTRITTO

5.7.10 Synchronization

MediorNet is a synchronized network to broadcast digital Video, Audio and data signals in real-time. The synchronization of the system can be done internally or by an external synchronization source. One MediorNet Frame serves the synchronization clock and is defined as Sync-Master. In case this Frame fails, another Frame will take over the synchronization responsibility to synchronize the network. By setting synchronization priorities, the Sync-Master can be defined. The synchronization information is supplied via fiber to all MediorNet Frames in the network. Hence all output signals are synchronous to each other, independent of the fiber length.

All settings can be found in the menu *System / Configure Frame Synchronization* (see chapter [Frame Synchronization](#)).

Frame Name	Sync State	Sync Error	Sync Priority	Sync In	Sync Out	VITC Out	Leading Sync Out (500 µs)	TC Source	TC Mode
ES_Studio_110	Slave		None	None	Blackburst NTSC	<input type="checkbox"/>	<input type="checkbox"/>	Internal	
V11_Compact Pro	Slave		None	None	TriLevel 1080pF 24	<input type="checkbox"/>	<input checked="" type="checkbox"/>	Internal	
V12_Compact Pro	Slave		None	None	Blackburst PAL	<input checked="" type="checkbox"/>	<input type="checkbox"/>	Internal	
VK2_Compact Basic	Slave		None	None	Blackburst NTSC	<input type="checkbox"/>	<input type="checkbox"/>	Internal	
VK3_Compact Pro	Slave		None	None	WC 48Hz	<input type="checkbox"/>	<input type="checkbox"/>	Internal	
VK4_Compact Pro	Slave		None	None	WC 48Hz	<input type="checkbox"/>	<input checked="" type="checkbox"/>	Internal	
Compact Tel	Master locked		None	WC 48Hz	WC 48Hz	<input type="checkbox"/>	<input checked="" type="checkbox"/>	Internal	PAL
Medior 111	Slave		None	None	Blackburst PAL	<input checked="" type="checkbox"/>	<input type="checkbox"/>	Internal	
Medior 112	Slave		None	None	WC 48Hz	<input type="checkbox"/>	<input type="checkbox"/>	Internal	
TL_101_100	Slave		None	None	WC 48Hz	<input type="checkbox"/>	<input type="checkbox"/>	Internal	
TL_102_800	Master Master		Master	None	WC 48Hz	<input type="checkbox"/>	<input type="checkbox"/>	Internal	PAL
TL_103_800	Slave		Tertiary Master	None	WC Pulse 50Hz	<input type="checkbox"/>	<input type="checkbox"/>	Internal	
TL_104_714	Slave		None	None	WC Pulse 50Hz	<input type="checkbox"/>	<input type="checkbox"/>	Internal	

Figure 306: Frame Synchronization

In the default setting (no priority is set) the Frame with the highest serial number is defined as Sync-Master. After defining the priorities (None, Master, Secondary Master, Tertiary Master) of the Frames, the Frame with the highest priority is switched to Sync-Master. If this Frame fails, the Frame with the next priority overtakes the synchronization distribution.

If an external synchronization signal (Blackburst, TriLevel, WordClock) is attached to the Frame, the synchronization format is displayed in the field *Sync In*.

If a failure is detected on the external synchronization signal, the error is displayed in the *Sync Error* field. The format of the output synchronization signal is displayed in the *Sync Out* field.

By checking the checkbox *VITC Out*, the MediorNet Timecode is embedded in the Sync-Signal.

By checking the checkbox *Leading Sync Out*, the Sync signal at the *SYNC OUT* port of this Frame is generated 500µs before the MediorNet wide sync signal.

TC Source and *TC Mode* show information's, if a Timecode is detected on the external connected synchronization signal at *SYNC IN* port.

The button *Restore Sync. Priorities* switches back to the original Sync-Master (f.i. if a Secondary Master was used). A short signal interruption may occur by changing the Sync-Master.

USO RESTRITO

5.7.11 Timecode

MediorNet supports 3 timecode sources:

LTC	<p>An external LTC signal needs to be connected to an Audio Channel (Audio Mono Channel, AES, MADI, ...). This Channel needs to be routed to the LTC-Channel at the Sync Master.</p> <p>LTC Channels are in:</p> <p>MN-Modular -> XSS-16 -> Channel 6</p> <p>MN-Compact -> Main Module -> Channel 1</p>
VITC	<p>An external Sync Signal (Blackburst) with integrated VITC needs to be connected to the Sync In Port at the Sync Master.</p>
Internal	<p>If LTC and VITC are not available at the Sync Master, MediorNet generates the Timecode internally.</p>

Any Sync *Out* port configured for PAL or NTSC will carry the timecode.

The source of the timecode is displayed in the [Frame Synchronization View](#) in the column TC-Source and in the row of the Sync Master.

Multiple timecode sources can be connected simultaneously but only one timecode is used for the system. The system automatically uses the timecode signal with the highest priority.

1	LTC (highest priority)
2	VITC
3	Internal (if no external timecode signal available)

Please refer also topic *VITC Input* in chapter [Frame Synchronization](#).

USO RESTRITTO

5.7.12 Bandwidth

MediorNet is broadcasting the data via high-speed fiber links, thus a basic knowledge about this medium is required. All links of the LINK-Cards are duplex-links. SFP-Modules are used for the electrical / optical conversion. These transceivers have an independent transmitter and receiver part with a defined wavelength. The CWDM links are only possible over single mode fiber.

▼ Display of used bandwidth

The amount of actual used bandwidth is shown in the *DEVICE BROWSER*. Please take care, that the box *Show Link Cards* is checked. The actual usage is displayed left of the link status icon.

For instance 75% means, that a quarter of the bandwidth of the link is still available.

The information of used bandwidth is also in the STATUS-window of the LINK-Card available. Just right-click on the desired LINK-Card and choose in the context menu the option *Status* (see chapter [MN-LNK2,4 STATUS](#)).

▼ Overview of required bandwidth

The required bandwidth is calculated in MediorNet in timeslots (TS).

Each link offers 512 timeslots for the data transfer. More data in a signal requires more timeslots on a link.

In following table are the required timeslots for the different signal types listed.

Signal	required TS
Mono Audio @ 48 kHz	1
Mono Audio @ 96 kHz	1
AES 2ch Audio @ 48 kHz	2
AES 2ch Audio @ 96 kHz	2
MADI 64ch @ 48 kHz	64
MADI 32ch @ 96 kHz	32
RockNet 128ch @48 kHz	128
SD-SDI / DVB-ASI	45
HD-SDI (1080i, 720p)	235
3G SDI (1080p)	467
Ethernet 10 Mbit	3
Ethernet 100 Mbit	17
Ethernet 1 Gbit	158
Serial	1
GPI	1

▼ Calculation of required bandwidth

The required bandwidth can be calculated as follows:

The amount of transmitted signals and their bandwidth (TS) are known and will be summed. For example:

3G-SDI Signal (camera 1, embedded Audio)	470
3G-SDI Signal (camera 2, embedded Audio)	470
3G-SDI Signal (camera 3, embedded Audio)	470
3G-SDI Signal (camera 4, embedded Audio)	470
3G-SDI Signal (camera 5, embedded Audio)	470
6-Channel surround Audio (6x1.536 Mbit/s)	6
6-Channel surround Audio (6x1.536 Mbit/s)	6

Total Timeslots	2362

Each SFP transceiver transfers 512 timeslots in the MediorNet system.

total required timeslots	2362
divided by	/
available timeslots per link	512

amount of required duplex links	4,61 -> 5

A more comfortable calculation can be performed with the *MediorNet Timeslot Calculator*.

This Tool is available for download on the [Riedel Website](#): *Download -> Software & Firmware*

USO RESTRITTO

5.7.13 Firmware-Update

To update the firmware of the MediorNet system, the Java application *MediorUpdate_x.xx.xxxx.jar* is required. This software can be downloaded directly from the HTML site of any Frame.

Please take care that the filename extension is *.jar*.

This tool can be alternately downloaded from the Riedel homepage *Download -> Software & Firmware*.

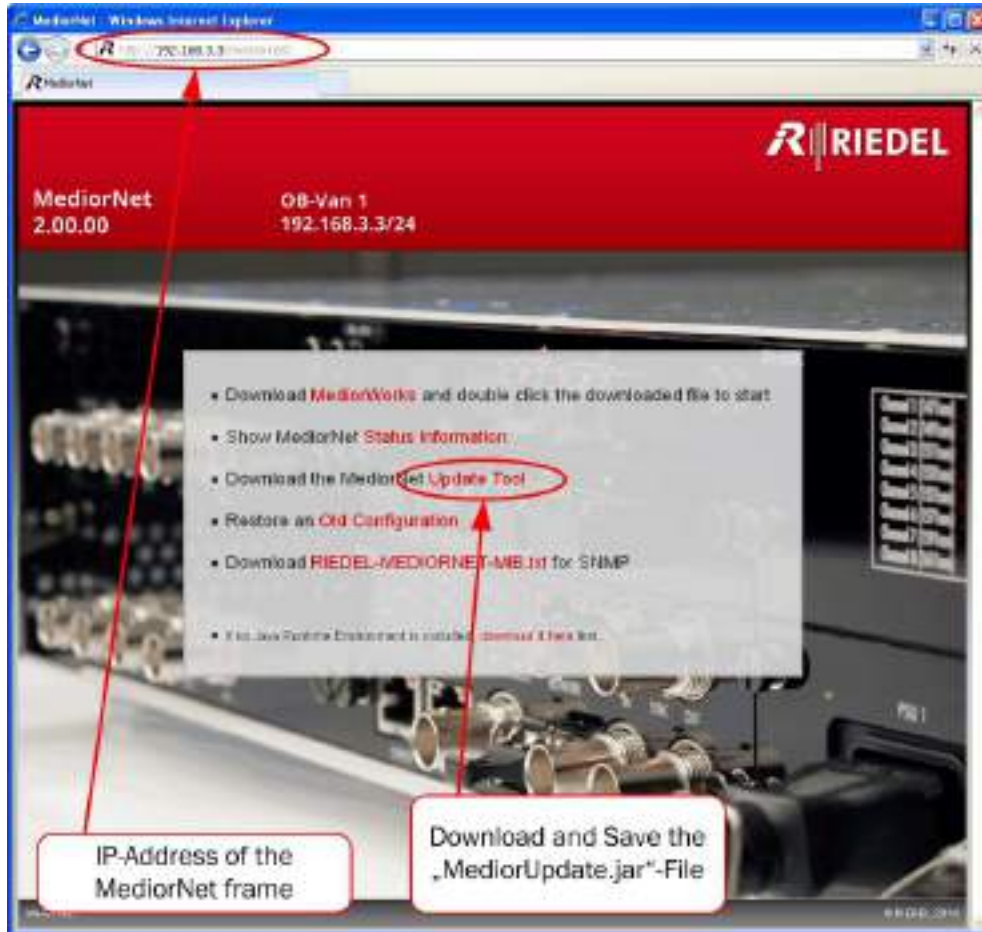

Figure 307: HTML Website of MediorNet

USO RESTRITO

After executing MediorUpdate the selection of the network interface Card, which is hooked to the system, is required. This is only the case if multiple network interfaces are present in the PC.

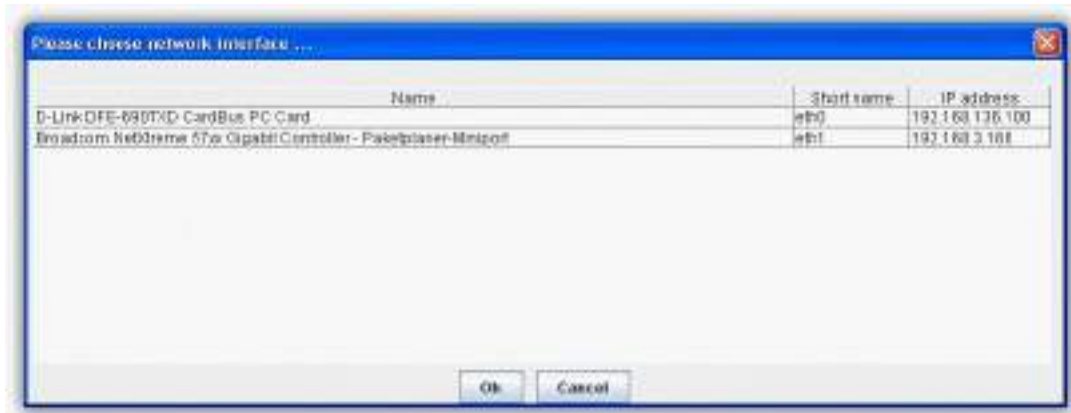

Figure 308: Selection of Network adapter

The MediorUpdate main page opens and all attached MediorNet Frames of the network are displayed.

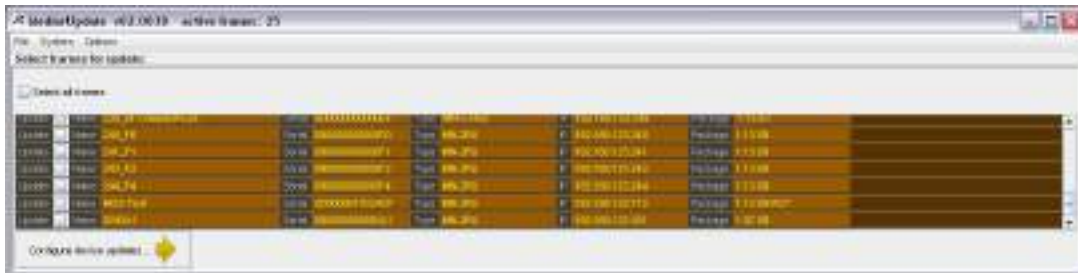

Figure 309: MediorUpdate

USO RESTRITO

The user needs to check all Frames to be updated on this *main page*. This can be done by checking individually Frame by Frame or by checking the box *Select all frames*.
If the field *Expert Mode* is checked in the *Options Menu*, the user is able to customize the update configuration on the next *Configuration and Update Progress Page*.
Is the field *Expert Mode* unchecked, the settings on the next page cannot be changed.

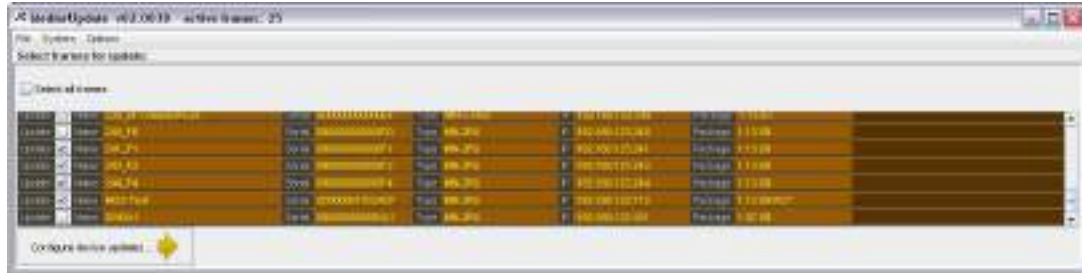

Figure 310: Selection of the Frames

Clicking the button *Configure device updates ...* will open a window to select the firmware package.

	All required files for the update are included in a <i>.zip</i> file. This file must not be unpacked. You need to select a complete <i>.zip</i> file.
--	---

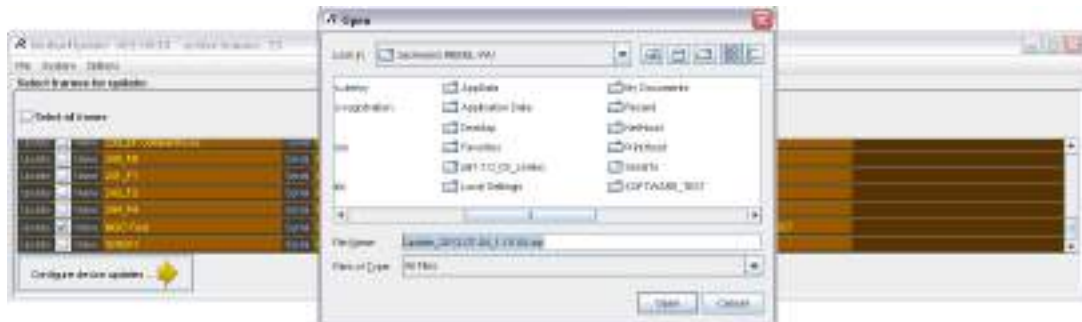

Figure 311: Open the Firmware

USO RESTRITO

Now all attached Frames including all equipped Cards are displayed on the *Configuration and Update Progress Page*. Further the actual firmware and the firmware to be updated are shown. If the field *Expert Modewas* checked in the *Options Menu* on the *main page*, the user is able to customize the update configuration on this page. If the field *Expert Modewas* unchecked, the settings on this page cannot be changed and all available Cards/ components are updated.



Figure 312: Overview of all Card Versions

By clicking the button *Start update ...* the update procedure is triggered. Bargraphs informs on the same page about the update progress of the single Cards/components.



Figure 313: Update in progress

USO RESTRITO

5.7.14 Reset Frame to factory default

To delete all settings of a Frame and reset the IP address to 169.254.1.1 you need to reset the Frame to factory default values. On the MN-XSS Card is a little hole above the term *MADI 2*. On the MN-Compact Frame it is located on the right side of the *MADI 1* port below the *SYNC* connectors. With a thin tool, for instance a paper clip, you are able to press the button behind.

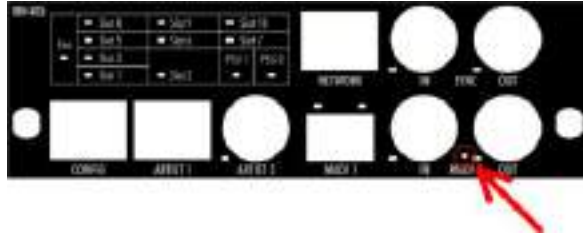

Figure 316: Reset Button of MN-XSS

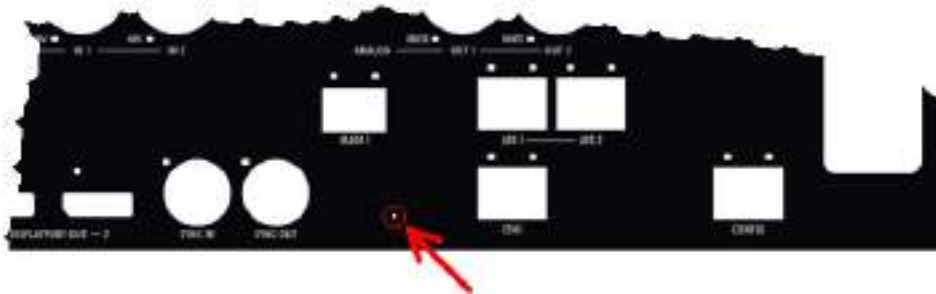



Figure 317: Reset Button of MN-Compact

short push	Restart of the Frame (equal to a power cycle)
long push (more than 4 seconds)	Frame is reset to factory default settings

	<p>All Settings in the Frame are deleted by resetting a Frame. The IP of the Frame is set to 169.254.1.1</p>
---	---

USO RESTRITO

5.8 Menus of MediorWorks Software

In this chapter all MediorWorks menus are listed in the order of appearance.

5.8.1 File

The actual system configuration of the MediorNet network is stored on a SD card in the MN-XSS Card. This configuration can also be stored in a file on your PC.

5.8.1.1 Backup System Configuration

To store the system configuration it is necessary to select the desired Frame by the checkbox *Save* or by selecting all Frames by the checkbox *Select all*. In the comment field the user can enter additional information about this configuration.



Figure 318: Backup System Configuration

After clicking *Save* a system window will open and let the user change the folder and name of the configuration file.



Figure 319: Save the System Configuration

USO RESTRITO

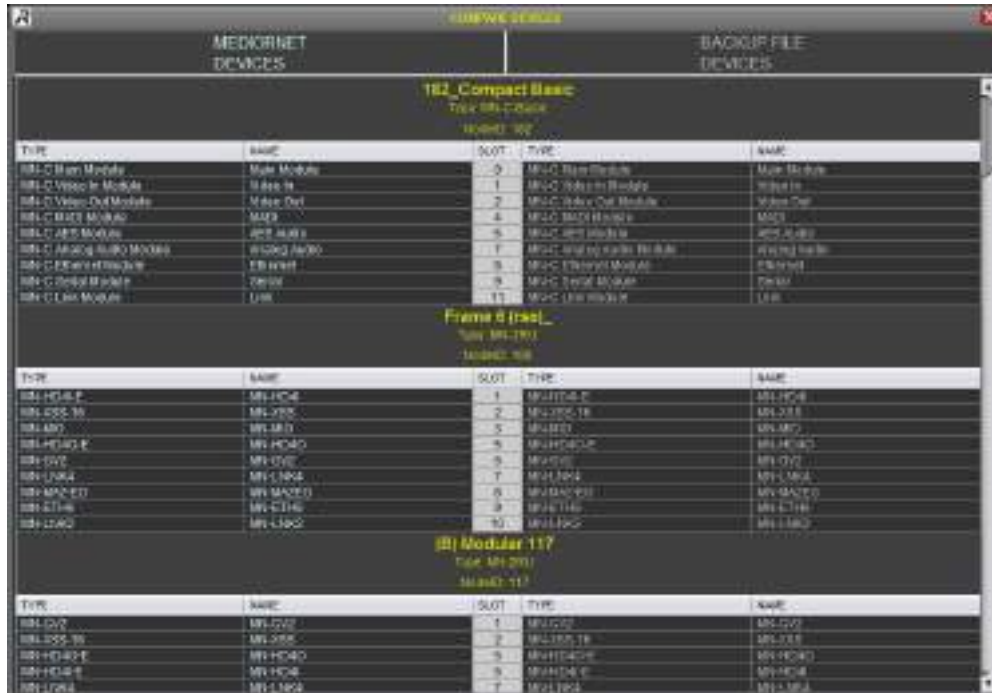

TYPE	NAME	SLOT	TYPE	NAME
MN-C Ram Module	MN-C Ram Module	0	MN-C Ram Module	MN-C Ram Module
MN-C Video In Module	Video In	1	MN-C Video In Module	Video In
MN-C Video Out Module	Video Out	2	MN-C Video Out Module	Video Out
MN-C MIO Module	MIO	4	MN-C MIO Module	MIO
MN-C JES Module	JES-8000	5	MN-C JES Module	JES-8000
MN-C Analog Audio Module	Audio In/Out	1	MN-C Analog Audio Module	Audio In/Out
MN-C Ethernet Module	Ethernet	3	MN-C Ethernet Module	Ethernet
MN-C Serial Module	Serial	3	MN-C Serial Module	Serial
MN-C Low Module	Low	11	MN-C Low Module	Low

TYPE	NAME	SLOT	TYPE	NAME
MN-HS-E	MN-HS-E	1	MN-HS-E	MN-HS-E
MN-SS-16	MN-SS-16	2	MN-SS-16	MN-SS-16
MN-AB	MN-AB	5	MN-AB	MN-AB
MN-HC40-E	MN-HC40	5	MN-HC40-E	MN-HC40
MN-DV2	MN-DV2	5	MN-DV2	MN-DV2
MN-LM4	MN-LM4	7	MN-LM4	MN-LM4
MN-BACTD	MN-BACTD	5	MN-BACTD	MN-BACTD
MN-ETH	MN-ETH	3	MN-ETH	MN-ETH
MN-LM2	MN-LM2	7	MN-LM2	MN-LM2

TYPE	NAME	SLOT	TYPE	NAME
MN-DV2	MN-DV2	1	MN-DV2	MN-DV2
MN-SS-16	MN-SS-16	2	MN-SS-16	MN-SS-16
MN-HC40-E	MN-HC40	5	MN-HC40-E	MN-HC40
MN-HS-E	MN-HS-E	5	MN-HS-E	MN-HS-E
MN-LM4	MN-LM4	7	MN-LM4	MN-LM4

Figure 322: Compare Devices

5.8.1.3 Exit

The command *Exit* will close MediorWorks after a confirmation prompt.

5.8.2 Workspace

The Workspace of MediorWorks is based on windows (see chapter [Views](#)). The default Workspace offers the user three different selections:

- CONNECTIONS (shows the *DEVICE BROWSER* and the *CONNECTIONS*-window)
- TOPOLOGY
- ALARM

The user has also the possibility to create own Workspaces:

On every Workspace is displayed in the right bottom corner an overview of the MediorNet Frame. This overview is independent of the present windows in this Workspace. This overview shows the different slot positions, the fixed position of the MN-XSS Card and the *Low-Speed-Slots* 3 and 8.

By a right-click on a Workspace button a context-menu will appear and offer the possibility to change the respective Workspace name or to delete it.

USO RESTRITTO

5.8.2.1 New Workspace

The command *New Workspace* will open a new, empty Workspace. First the name of this Workspace needs to be entered. This new Workspace is visible in a tab below the menu bar. This Workspace is user related and stored only on the local PC.

5.8.2.2 Restore Default Workspaces

The command *Restore Default Workspaces* will restore the default Workspaces *CONNECTIONS*, *TOPOLOGY* and *ALARM*. User defined Workspaces won't be changed.

5.8.2.3 Delete Workspace

The command *Delete Workspace* will delete the actual Workspace without confirmation.

5.8.3 System

In the system menu settings like IP-addresses of Frames, synchronization and system time can be changed.

5.8.3.1 Network Interface

The communication between MediorNet and the attached PC is handled by a 100 Mbit/s Ethernet port. Is a PC equipped with more than one NIC or further virtual network ports, a definition of the NIC is required, which is attached to the MediorNet system.

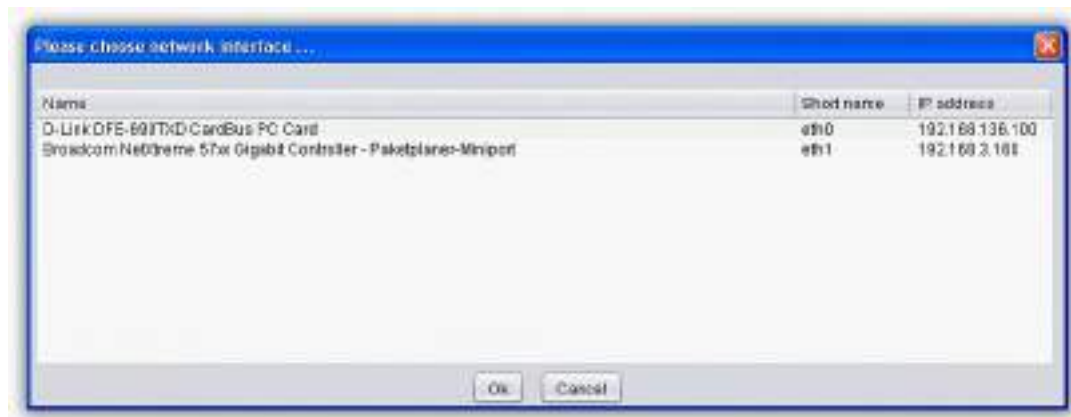

Figure 323: Configure Network Interface

5.8.3.2 Frame Synchronization

MediorNet is synchronous working platform. In a network is one Frame defined as Sync-Master and the other Frames are Sync-Slaves and will be synchronized to the master's clock. If no external clock is supplied to the network and all Frames are set to the same priority, the Frame with the highest hardware ID takes care about the clock distribution (see also chapter [Synchronization](#)).

Frame Name	Sync. State	Sync. Error	Sync. Priority	Sync. In	Sync. Out	WFC Out	Leading Sync. Out	TC Source	TC Mode
00_Producer 112	Slave		None	None	Backup NTSC			Internal	
01_Compact Pro	Slave		None	None	Relay 1000AF 2K			Internal	
02_Compact Pro	Slave		None	None	Master PAL			Internal	
03_Compact Slave	Slave		None	None	Backup NTSC			Internal	
04_Compact Pro	Slave		None	None	VC 4894			Internal	
05_Compact Pro	Slave		None	None	VC 4894			Internal	
06_Slave 111	Master locked		None	VC 4894	VC 4894			Internal	PAL
Master 111	Slave		None	None	Backup PAL			Internal	
Master 112	Slave		None	None	VC 4894			Internal	
TL_TL 111	Slave		None	None	VC 4894			Internal	
T2_S2 201	Master locking		None	None	VC 4894			Internal	PAL
T3_S3 301	Slave		Tertiary Master	None	VC Pulse 4894			Internal	
T4_S4 401	Slave		None	None	VC Pulse 4894			Internal	

Figure 324: Frame Synchronization

▼ **Frame**

The name of the Frame is displayed in this field.

▼ **Sync. State**

Master locked	Frame has a sync source connected to sync in and has highest priority in the MediorNet. Frame runs synchronized to a direct connected Audio or Video sync source.
Master locking	Frame has a sync source connected to sync in and has highest priority in the MediorNet. Frame found a direct connected Audio or Video sync source and is in synchronization procedure.
Master freerun	Frame has highest priority in the MediorNet. No Frame in the MediorNet is connected to a sync source.
Slave	Frame runs synchronous to the MediorNet Master. Frame has not the highest priority in MediorNet or no sync source is directly connected to it.

▼ **Sync. Error**

Sync Lost	<i>Sync Lost</i> appears on the sync master when it detects an error in the sync signal during it is locked to it. Frames with <i>Sync Lost</i> indication get lower priority than all other Frames excepting Frames with priority <i>none</i> to avoid the switchback if the Sync come back.
	The error detection can be set back by pressing the <i>Restore Sync. Priorities</i> button.

USO RESTRITO

▼ **Sync. Priority**

Master	Highest priority. Frame becomes sync master when error free sync signal is detected on sync input and no other Frame has same configuration.
Secondary Master	Second priority level. Frame becomes sync master when error free sync signal is detected on sync input and no other Frame has same configuration and higher or same priority.
Tertiary Master	Third priority level. Frame becomes sync master when error free sync signal is detected on sync input and no other Frame has same configuration and higher or same priority.
none	No priority is set to this Frame. Frame can only become sync master in MediorNet when no other Frame has higher priority settings.

▼ **Sync. In**

Shows which type of sync signal is connected on *Sync In*.

▼ **Sync. Out**

Selects which [sync signal](#) type should be generated on the output. It's possible to generate sync signals of different types on different Frames.

▼ **VITC Out**

Enable or disable of embedding the timecode in the Sync-signal.

▼ **Leading Sync. Out**

The Sync signal is generated 500µs before the MediorNet wide sync signal.

▼ **TC Source**

The MediorNet acts as a timecode generator if the sync master does not detect a VITC on the *Sync In* port, or if the *Sync In* is lost. In this case the *TC Mode* must be set.

When *Sync Out* ports are configured for *Blackburst PAL* the VITC is in lines 19 and 21, when configured for *Blackburst NTSC* the VITC is in lines 14 and 16.

Reports the TC format of the currently connected sync in signal, left blank if there is no sync in or no valid TC. Possible Values:

LTC	external Longitudinal (Linear) Timecode
VITC	external Vertical Interval Timecode
internal	internal Timecode

▼ **TC Mode**

Only modifiable on the sync master if no external TC is detected, otherwise the *TC Mode* is fixed to the *Sync In* TC Mode. Used to select how the timecode is counted. The same values as in the *TC Source* column apply.

▼ **Button Restore Sync. Priorities**

The original Sync-Master is switched back after pressing the button (f.i. if a Secondary Master was used). A short signal interruption may occur by changing the Sync-Master.

USO RESTRITO

▼ MediorNet sync master selection

The decision which Frame becomes master follows a few decisions. The first Frame, which can answer the following questions beginning by 1.) with yes, become sync master.

1.)	Is a sync signal detected on the Sync Input?
2.)	Is the sync priority set to any other level than <i>none</i> ?
3.)	Is the sync signal error free?
4.)	Is the sync priority higher than that of other Frames?

If some Frames have the same answers to all questions, the decision is done by a unique Frame ID.

Rank	Sync. Priority	Sync. Error	Sync. In
1	Master	none	detected
2	Secondary Master	none	detected
3	Tertiary Master	none	detected
4	Master	Sync Lost	detected
5	Secondary Master	Sync Lost	detected
6	Tertiary Master	Sync Lost	detected
7	none	none	detected
8	Master	none	none
9	Secondary Master	none	none
10	Tertiary Master	none	none
11	Master	Sync Lost	none
12	Secondary Master	Sync Lost	none
13	Tertiary Master	Sync Lost	none
14	none	none	none

5.8.3.3 Frame Address Properties

The window of the Frame Address Properties is splitted in three tabs: *IP Configuration*, *Node ID Configuration* and *MediorNet Finder*.

IP Configuration

The tab *IP Configuration* allows to enter and change the IP-based Addresses of the Frames.

▼ **Automatic IP**

The address assignment is done automatically in the Zeroconf range (169.254.1.1 to 169.254.254). This address range is also used in the factory default configuration.

▼ **DHCP IP**

(Dynamic Host Configuration Protocol) The address assignment is done automatically by a DHCP-Server in the TCP/IP-Network.

▼ **Static IP**

The Frame is set by the administrator to a fixed IP address and Net mask.

▼ **use Gateway**

If the MediorNet network is connected via a router, the gateway can be entered here to access the Frames across different networks.

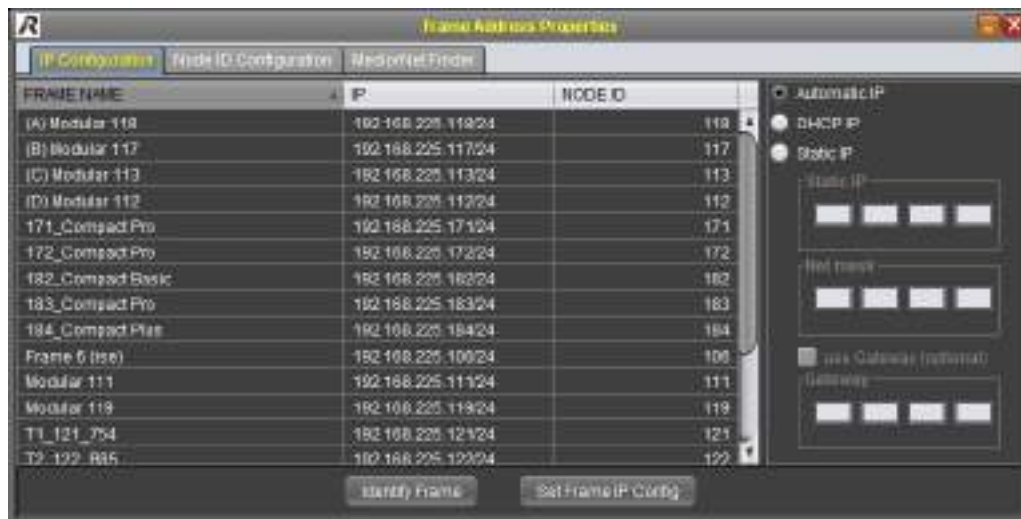

Figure 325: Configure Frame IP

The command *Set Frame IP Config* will store the settings in the selected Frame.

▼ **Identify Frame**

This command is useful to identify a specific Frame in a rack. After selecting a Frame and clicking *Identify Frame*, the front LEDs will start flashing for some time.

This feature is also available in the tab *Node ID Configuration*.

USO RESTRITO

Node ID Configuration

The tab *Node ID Configuration* allows to change the Node ID of a Frame.

The Node ID consists of numbers between 1 and 2.147.483.647. The entered Node ID is displayed in red characters if entered Node ID is already in use in the network. A valid Node ID is displayed in black characters.

After changing a Node ID successfully, the respective Frame is restarted. Thus the Frame will disappear in MediorWorks until it rebooted.

Changing the Node ID involves a risk to configure 2 Frames with the same Node ID. To prevent this the user will be informed about this and the changing is executed in two steps.

- 1) The user selects a Frame, enters a Node ID and clicks on the button *Replace Node ID*.



Figure 326: Node ID Configuration

- 2) A dialog appears and needs to be confirmed by the user.



Figure 327: Node ID Configuration dialog

USO RESTRITO

MediorNet Finder

The tab MediorNet Finder allows to search for attached MediorNet Frames in the network.

After selecting this tab the application searches automatically for attached MediorNet Frames in the network. All detected Frames are listed with their corresponding IP address. This tool is very useful to identify Frames with unknown IP-addresses. The IP configuration can be done in this tab, as well as in the tab [IP Configuration](#).



The *MediorNet Finder* is highly dependent on restrictions and implementations of the operation system it is running on. For instance on Ubuntu 9.10 it may happen that only when using the first Ethernet interface the user will yield the desired results. On Windows® on the other hand, restrictive firewalls may prevent the tool from working properly.

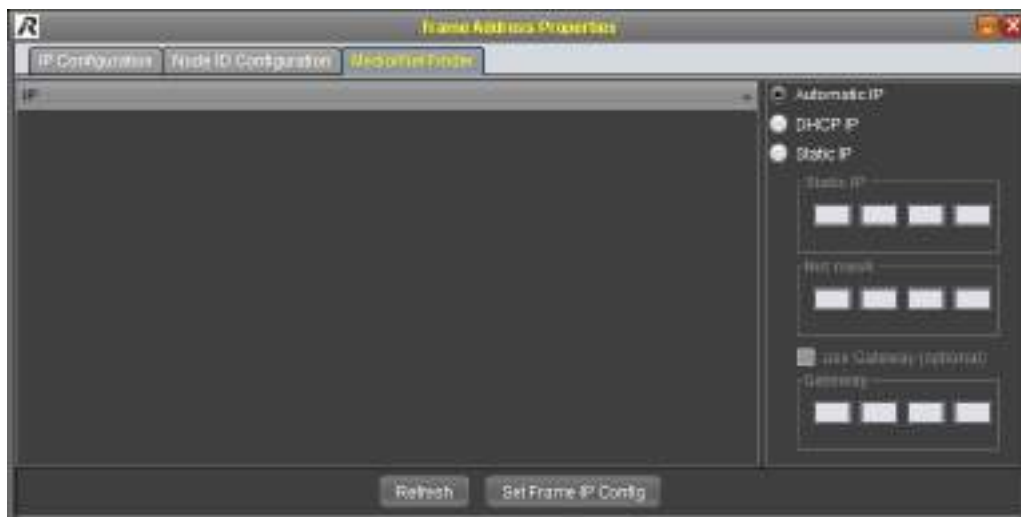

Figure 328: MediorNet Finder

USO RESTRITO

5.8.3.4 MediorNet Time

MediorNet displays in the upper section of the window the actual MediorNet time, the timecode and the local PC time.

Set MN Time sets the MediorNet time to the PC time.

Set TC sets the timecode to the PC time.

Set Both sets the MediorNet time, as well as the timecode to the PC time.

Another way is to enter manually the date and time in the lower section of the window.

After choosing date and time the values are also set into the system with the buttons below.

Set MN Time sets the MediorNet time to the manual entered time.

Set TC sets the timecode to the manual entered time.

Set Both sets the MediorNet time, as well as the timecode to the manual entered time.



Figure 329: MediorNet Time

USO RESTRITO

5.8.3.5 Reboot/Restart Frames

In this window the user has the option to restart the Frames in two ways:

SOFT RESTART will restart the selected Frames (warm start). This will interrupt the data transfer of the established connections for about 2 seconds.

REBOOT will reboot the selected Frames (cold start equals to power cycle). This will interrupt the data transfer of the established connections for about 1 minute.



Figure 330: Reboot / Restart Frames

USO RESTRITO

5.8.3.6 Card Reset/Factory Default

This window allows the user to reboot single Cards or to reset single Cards to factory default. Select one or more Cards by a left mouse click (in combination with *SHIFT- / CTRL*-key on the keyboard). By pressing *Reset Card(s)* the selected Cards will reboot. By clicking *Set Factory Defaults* the Cards are set to factory default settings.

Rebooting will take approximately 1 Minute. Audio- and Video connections are interrupted during this time.



Figure 331: Card Reset / Factory Default

	Set <i>Factory Defaults</i> will delete all settings on the respective Cards.
--	---

USO RESTRITTO

5.8.3.7 System Info

The window of the System Info is splitted in two tabs.

The tab *Hardware* displays all system information like hardware of the complete network, firmware version, FPGA version, temperature etc.

The tab *Connections* displays all created Video, Audio and data connections.

These information's can be stored in a text based file on the local PC by pressing menu *file -> save*

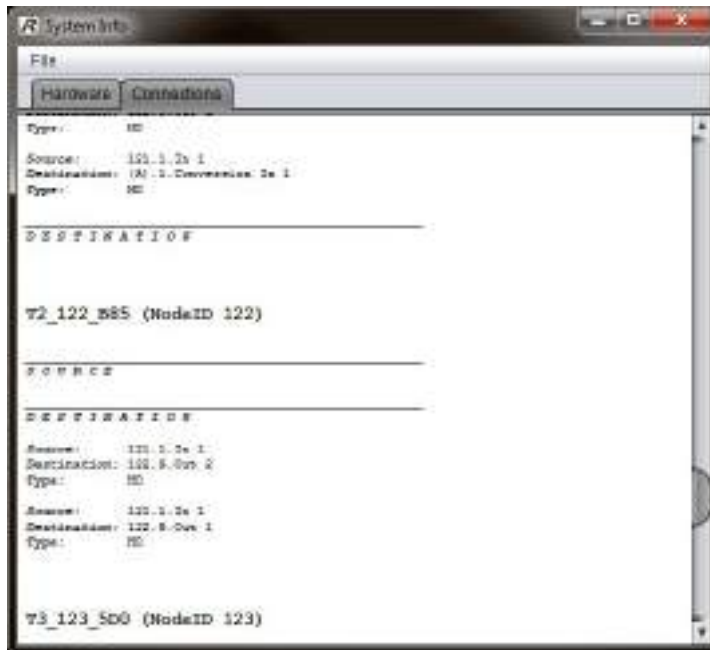

Figure 332: System Info Connections

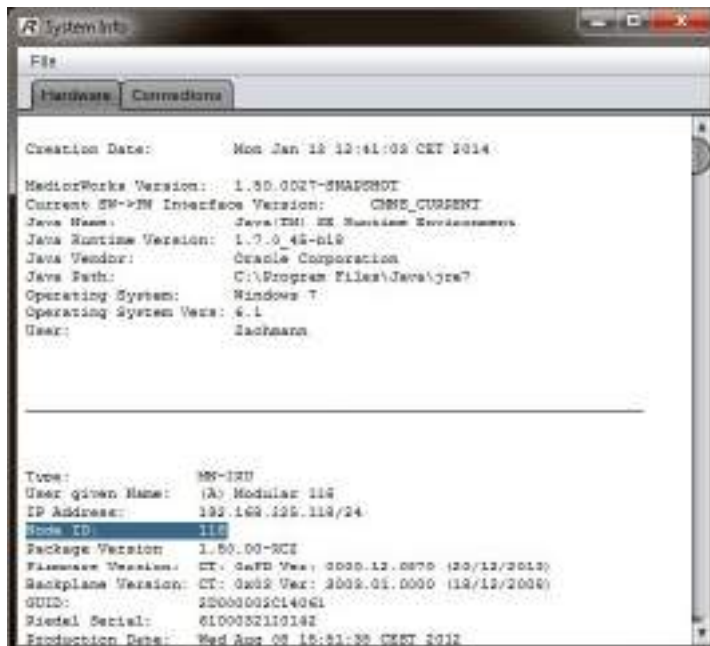

Figure 333: System Info Hardware

USO RESTRITTO

5.8.3.8 MediorWorks Password

The access to the MediorWorks software can be protected by a password. The password authorization is limited to the local PC attached to the network. It is not a user right management for the system. To change to password it is necessary to enter the actual password and two times the new password.



Figure 334: MediorWorks Password

5.8.3.9 Service Handler

In the MediorNet network is one Frame responsible for the internal communication between Frames and the MediorWorks software like routing, synchronization etc. This Frame is called *Service Handler*. MediorWorks is now able to use up to ten Service Handler. Case of application are IP separated MediorNet Systems maintained together in one MediorWorks instance. Thus, connections of different networks can be routed to transfer data between in- and outputs of IP separated networks.

The *Service Handler* can be selected automatically by the system itself when choosing the option *Scan local network*. It's also possible to define a specific Frame as service handler by choosing the option *Use fixed IP address(es)*. In this case the IP address of the desired Frame needs to be entered in the fields below. The amount of Frames (1-10) can be selected with the +/- buttons.



Figure 335: Configure Service Handler

5.8.4 Views

Following window settings are stored when closing the MediorWorks application:

- which window is open on which Workspace
- position of window
- size of window
- state of window (normal, minimized, maximized)

These settings are restored when the application starts the next time.

An exception is the TOPOLOGY and the MATRIX. These windows are free and not docked within the MediorWorks software.

5.8.4.1 DEVICE BROWSER

By choosing this menu item the DEVICE BROWSER is opened in the actual Workspace.

In this window all Frames in the MediorNet network and all equipped Cards are displayed. The DEVICE BROWSER as well as the [MATRIX](#) are the platform for the [creation of connections](#). It is divided in following regions:



Figure 336: DEVICE BROWSER - window

Source / Destination

In the SOURCE-region the user is able to define the origin signal to be routed through the MediorNet network. In the DESTINATION section is the selection of the destination of the transported signal.

	<p>In the SOURCE-region are displayed only input Cards and input Channels. In the DESTINATION-region are displayed only output Cards and output Channels. Bidirectional Channels are displayed in both regions.</p>
---	---

USO RESTRITO

1. Column - Frames

In this region the name of all Frames in the MediorNet network are displayed.



Figure 337: Frames

	2 Icons inform about the state of the redundant power supplies.
Name	Name of the Frames. In the default configuration the name is generated out of the Frames serial number and the text <code>_UNDEFINED_NAME</code> .

2. Column - Cards

In this region the Cards in the selected Frame are displayed.

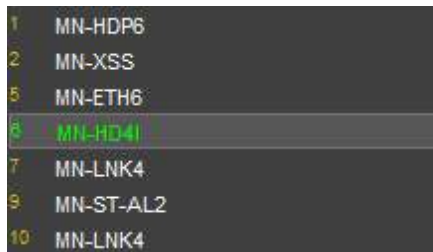



Figure 338: Cards

	Slot position of the Card in the Frame
Card Name	available Cards in the selected Frame

USO RESTRITTO

3. Column - Channels

In this region the Channels of the selected Card are displayed.



Figure 339: Channels

8.4	Slot.Channel (Slot and Channel-Number are separated by a dot)
	An icon informs about the state of the Channel / test signal
Signal type	An icon informs about the type of the Channel (SD , HD , MADI , AES3 , ...)
*1	Shows the Reroute Priority , if assigned.
Channel Name	Name of the Channel. In the default configuration the name is generated out of the Node ID of the Frame, the slot number, the name of the Channel and the Channel-number.
Utilization *2	Shows the link utilization (in %)
Plug Type	Type of the physical plug (BNC , SFP , RJ45 , ...)
Connection State *2	Shows an active connection ()

*1 only at Destination Channels

*2 only at LINK-Cards

	If a Frame is selected, all Channels of all Cards of this Frame are displayed. If a Card is selected, only the Channels of the selected Card are displayed.
--	--

USO RESTRITTO

4. Column - SubChannels

In this region the SubChannels of the selected Channel are displayed.



Figure 340: SubChannels

2.1.1	Slot.Channel.SubChannel (Slot, Channel- and SubChannel-Number are separated by a dot)
Signal type	An icon informs about the type of the SubChannel (AUD , ...)
... *	Shows the Reroute Priority , if assigned.
SubChannel Name	Name of the SubChannel. In the default configuration the name is generated out of the Node ID of the Frame, the slot number, the Channel-number and the name of the SubChannel.

* only at Destination Channels

	Not embedded Video-Out-SubChannels (Audio mono channels) are displayed by orange letters.
--	---

USO RESTRITTO

Checkboxes / Buttons

Display connected source channels	If the checkbox is enabled and an output Channel is involved in a connection, the name of the input Channel is displayed on the output Channel.
Show Link Cards	If the checkbox is enabled the LINK-Cards in the system are displayed. In default configuration the LINK-Cards are hidden.
MANUAL ROUTING	By default you don't need to take care about the network topology for the routing. MediorNet detects all attached Frames automatically and calculates the shortest route. It's also possible to choose the way of the route manually. To do so it is required to check this checkbox before creating a connection.
Bidirectional	By default connections are established unidirectional. For some signals, for instance for MADI, it is possible to create bidirectional connections. To do so it is necessary to check this checkbox before creating the connection.
Locked	If this checkbox is enabled before creating a connection, the connection is protected against a single click delete. In this case a confirmation dialog is opened before the connection is deleted.
Connect	If the source and destination selected, this button establishes a connection. This connection is directly active and is displayed in the <i>CONNECTIONS</i> -window. This button is only enabled if source and destination are compatible. Otherwise the button is grayed out and it isn't possible to create connections.

Detailed information of setting up connections can be found in the chapter [Setup a Connection](#).

Filter

The Filter feature is located right beside the DEVICE BROWSER.

Only the selected Channels are displayed (all, Audio, Video and Data). This is very useful to simplify the handling of complex system setups and to find easily the required signals.

A Split-Pane-Bar on the left side allows to change the proportion of the filter.



Figure 341: DEVICE BROWSER - Filter

all	Filter is disabled. All Cards, Channels and SubChannels are displayed.
Audio	Only Audio Channels are displayed.
Video	Only Video Channels are displayed.
Data	Only Data Channels are displayed.

Context menu

By right-click on Frames, Cards, Channels or SubChannels a context menu is displayed and offers different options. These options vary depending on the selected item.

In total following options are available:

Format	see chapter Formats
Test Pattern	see chapter Test Pattern
Show Connection(s)	see chapter CONNECTIONS
Show Connection Overview	see chapter Connection Overview
Status	see chapter STATUS - window
Configuration	see chapter CONFIGURATION - window
Show remote link end	In the destination region of the DEVICE BROWSER is the LINK-Card displayed, which is connected with the LINK-Card in the source region (and vice versa).
Show Source	Displays the source Channel.
Show Connection	see chapter CONNECTIONS
Delete Connection (of Selected Channels)	The connection / crosspoint is deleted (all connections of the multiple selection are deleted)
Set Reroute Priority to	see chapter Re-routing Priority
Test Signal On	Enable / disable the Audio test signal
Mute	Enable / disable the Audio output signal
OSD On	Enable / disable the On-Screen Display see chapter OSD On-Screen Display
Video Off	Enable / disable of the Video output signal

Following keyboard shortcuts are available in the DEVICE BROWSER:

CTRL + C	A new connection will be created, if a source and destination Channel is selected.
"Del"	Deletes a connection, if a destination Channel is selected.
Arrow-cursor-keys	Changes the selection to the respective direction.
ALT + arrow-cursor-up/down	Changes the selection of source and destination in the respective direction.

5.8.4.2 CONNECTIONS

By choosing this menu item the *CONNECTIONS*-window is opened in the actual Workspace.



Figure 342: *CONNECTIONS* - window

In this window all connections in the MediorNet network are displayed. Not embedded Video-Out-SubChannels (Audio mono channels) are displayed by orange letters.

To keep overview in complex systems, the user is able to hide unwanted Channels. Following *CONNECTION FILTERS* are available:

all	Filter is disabled. All Cards, Channels and SubChannels are displayed.
Video	Only Video Channels are displayed.
Audio	Only Audio Channels are displayed.
Data	Only Data Channels are displayed.

These filters can also be combined with a text filter. Only those kinds of connections are displayed which are including the search text in the source and/or destination name.

The shown table is divided in 4 columns. Following information's are displayed:

Source	The name of the source is displayed here.
Destination	The name of the destination is displayed here.
Format	An icon informs about the signal format (see chapter Icons).
State	An icon informs about the actual state (see chapter Icons).
Priority	The priority level is shown here (see chapter Re-routing Priority).
Lock	A checked box informs about a locked connection.

The listed connection can be sorted by Source, Destination, Format, State, Priority and Lock. The sorting can be changed by single- or double-click on the desired criteria in the headline. The actual sorting order is indicated by an up-facing or down-facing triangle next to the criteria.

USO RESTRITTO

Closer information of a selected connection is displayed on the right side:

Frame	Name of the Frame (each for source and destination).
Card	Name of the Card (each for source and destination).
Channel	Name of the Channel (each for source and destination).
SubChannel	Name of the SubChannel (each for source and destination).
Slot	Slot number of the Card (each for source and destination).
Plug	Channel number (each for source and destination).
Hops	List of LINK-Cards involved in this connection.

By pressing the *Delete all* button on the bottom left of this window, all created connections are erased. The *Delete selected* button will erase only selected connections.

A context menu will appear by a right-click on a connection:

Show Error Details	(only visible if connection state is <i>damaged</i> or <i>state interrupted</i>)
Reroute selected Connection(s)	Apply re-routing of the connection
Show Channels in DEVICE BROWSER	selected channels are displayed in the <i>DEVICE BROWSER</i>
Delete selected	deletes the selected connections
Set Reroute Priority on Selection	Assignment of Re-routing Priority (see chapter Re-routing Priority)

By pressing the *Delete* key on your keyboard, the actual selected connection is deleted.

	A confirmation window will only appear on locked connections.
---	---

USO RESTRITO

5.8.4.3 LOGGING

By choosing this menu item the LOGGING-window is opened in the actual Workspace. This window will display all system messages after pressing the button *Load logging data*.

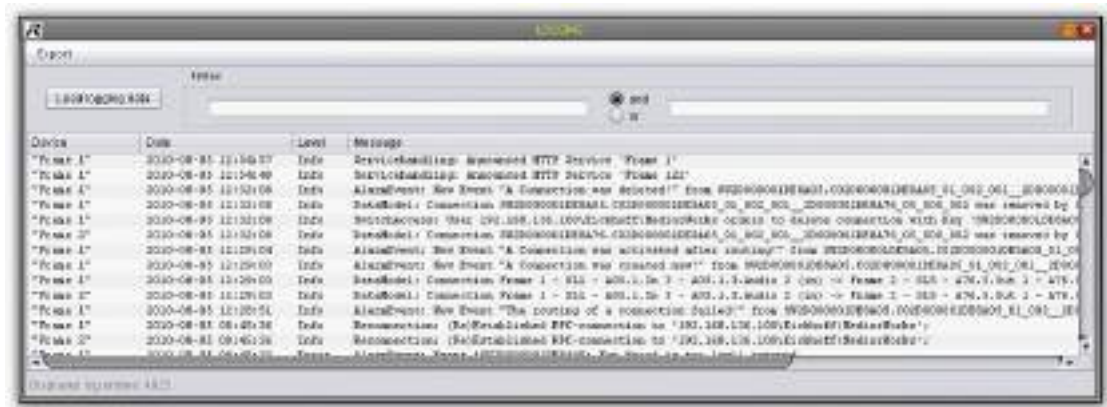

Figure 343: LOGGING - window

The text filter offers the feature to limit the list of messages. Only messages with the found criteria are visible. Two criteria can be combined by *and* or *or*.

The menu Export lets the user save the messages on the local PC. It's possible to save all messages or only the selected ones in *.csv* as well as in *.txt* format.

USO RESTRITO

5.8.4.4 EVENTS

By choosing this menu item the EVENTS-window is opened in the actual Workspace. In this window alarms, warnings and information are displayed. They are grouped in following categories: System Alarms, Topology Alarms, Connection Alarms, Warnings and Info. The single Events in this window are always double-spaced. Each content is also displayed as a tooltip.

Alarms are only visible, as long as the alarm is present. An alarm will disappear out of this list if it isn't persisting any more, for instance if a temperature returned to normal values.

The user is able to ignore alarms to move them to the list *Ignored Alarms*.

	Warnings and information are deleted after checking the checkbox <i>Ignore</i> and won't be visible in the <i>Ignored Alarms</i> region.
--	--



Figure 344: EVENTS - window

▼ Buttons

"Trigger Alarm LED" Checkbox ¹	If this box is checked, an alarm is indicated by a red blinking Status-LED in the bottom right Statusbar in MediorWorks.
"Ignore All" Button	In the Alarms tabs: All alarms displayed in the region <i>ALARMS</i> are moved to the region <i>IGNORED ALARMS</i> . In the Warnings and Info tabs: All entries are removed.

¹ The checkbox is only available in the tabs *System-Alarms*, *Topology-Alarms* and *Connection-Alarms*.

▼ Columns

Device	Displays the involved devices (Frame, Card, Channel, SubChannel).
Reason	Description of the Alarms, Warnings or Info.
Occurred	Timestamp of the Event.
Ignore	In the Alarms tabs: The entry is moved to the region <i>IGNORED ALARMS</i> . In the Warnings and Info tab: The entry is removed.
Confirmed at ²	Displays date and time of confirmation.
Confirmed by ²	Displays PC-Name and Log-In-Name of the confirming user.

² This column is only available in the region *IGNORED ALARMS*.

USO RESTRITO

5.8.4.5 GROUP EDITOR

By choosing this menu item the GROUP EDITOR-window is opened in the actual Workspace.

To manage the plenty of input and output signals comfortably, the user can define unlimited number of groups for his requirements. In every group unlimited number of signals can be assigned, independent of the signal type.

The single ports can be found much faster if they are thematically grouped for instance:

Video groups	All Video Channels of the complete system
Audio groups	All Audio Channels of the complete system
Data groups	All data Channels of the complete system

Or the signals will be assigned to input and output groups:

Input signals	All input signals of the complete system
Output signals	All output signals of the complete system

Or groups with different bandwidths will be created:

SD group	All SD input and SD output signals of the complete system
HD group	All HD input and HD output signals of the complete system

Or, or, or ...

A definition of these groups is absolutely required for the configuration within the [MATRIX](#), because only signals out of user groups are selectable.



Figure 345: GROUP EDITOR

USO RESTRITO

The desired group is created, deleted, duplicated or renamed in the region *GROUP*. The selection of the group is done in the drop down menu.

In the region *ALL CHANNELS* are listed all ports in the MediorNet network. To keep overview in complex systems, a filter can be applied on the list. The filter options can be combined and have the following functions:

Signal type	Only Channels of the selected signal type are visible: (Video, SD, HD, 3G) (Audio, MADI, AES3, Mono) (Data, Ethernet, Serial, GPI)
Signal direction	Only Channels with the selected signal direction are displayed: (Source, Destination) (bidirectional)
Frame	Only Channels of the selected Frame are visible.
Text	Only Channels contains the search text are displayed.

A left-click on a Channel will select it. More Channels can be selected by pressing *SHIFT* / *CTRL*-key on the keyboard while the left-click. By pushing the command ">" or by drag&drop, all selected Channels will be moved in the right field *CHANNELS IN GROUP*.

In the same way it is possible to remove a Channel out of a group. Select one or more Channels and use the button "<" or the drag&drop feature.

The command "<<" will remove all Channels from this group, also the invisible Channels hidden by the filter.

All Channels in the region *CHANNELS IN GROUP* can be applied with the same filter functions on the top of this region.

For some signals, for instance for MADI, it is possible to create bidirectional connections. To do so it is necessary to check the box *Bidirectional* before creating the connection. Otherwise the connection is created unidirectional from the source to the destination.

The name of the connection is generated out of the Frame name, slot and Channel The name can be modified later on in the CONNECTIONS-window.

The window of the matrix is an independent window and is not embedded within the MediorWorks software. If the box *On Top* is enabled, the window is focused permanently in the foreground.

By a right-click on a set crosspoint a context menu opens and offers the option to lock/unlock connections and to perform a reroute.



Figure 347: Right-click on Crosspoint in Matrix

USO RESTRITO

By a right-click on a Channel a context menu opens and offers different options depending on the signal type or if the Channel belongs to the source or to the destination. Overall following options are available:

Format	see chapter Formats
Test Pattern	see chapter Test Pattern
Show Connection(s)	see chapter CONNECTIONS
Show Source	Displays the source signal
OSD On	see chapter OSD On-Screen Display
Video Off	Enable/disable of the Video output signal
Delete Connection	The connection/crosspoint is deleted
Set Reroute Priority to	see chapter Re-routing Priority
Test Signal On	Enable/disable of the 1kHz Audio test signal
Mute	Enable/disable of the Audio output signal
Status	see chapter STATUS - window
Configuration	see chapter CONFIGURATION - window

5.8.4.7 TOPOLOGY

By choosing this menu item the TOPOLOGY-window is opened in the actual Workspace
 In this window the topology of the interconnected Frames will be displayed dynamically.
 This means new detected Frames are inserted and disconnected Frames are removed out of this view.

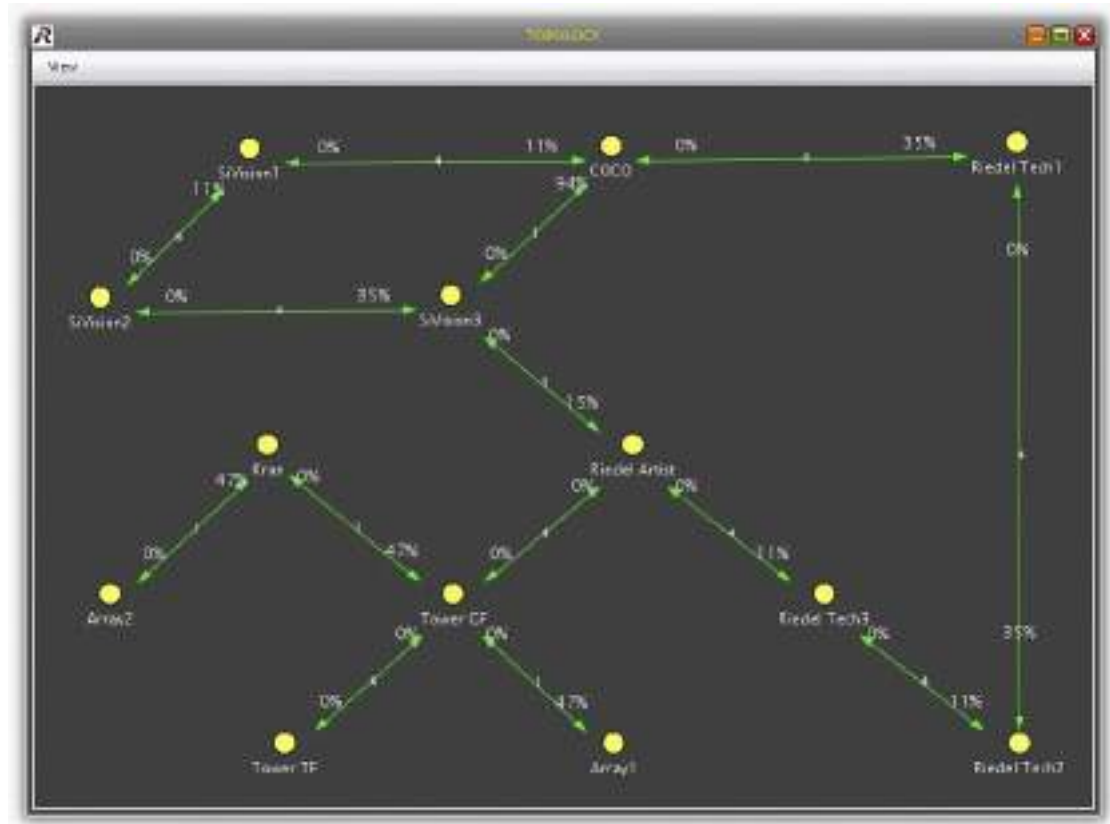

Figure 348: TOPOLOGY - window

A green line indicates all fiber- and CWDM-links between two Frames. The number in the middle on the green line shows the number of fiber links. The numbers on the both sides shows the fiber utilization in the respective direction. For instance, between the Frame "COCO" and the Frame "Riedel Tech1" in Figure LINK UTILIZATION - window:

4	Displays the number of fiber and/or CWDM links between "COCO" and "Riedel Tech1".
0%	Displays the fiber utilization between "Riedel Tech1" and "COCO".
35%	Displays the fiber utilization between "COCO" and "Riedel Tech1".

The value shows the average of each fiber / CWDM link and is calculated as follows:
 The sum of the actual used bandwidth between FRAME X towards FRAME Y
 divided by the number of present fibers and CWDM links between FRAME X and FRAME Y.

USO RESTRITTO

These values are updated dynamically. For instance, if a new link between FRAME X and FRAME Y has been established, all percent values are updated. If a link is lost or if a new link has been established, the number of the links are updated.

If there is no link at all between two Frames, the green line will disappear in the topology window.

The name of the Frame can be changed by double clicking on it

The Frames can be positioned by the user by drag&drop. It is also possible to move more Frames in the same time. To do this you need to select additional Frames by mouse-click while the CTRL key is pressed. More Frames can be also selected by dragging the mouse. This is indicated by a blue square in the background.

If the CTRL key is pressed the user can zoom in/out the window by rotating the wheel-mouse.

By rotating the wheel-mouse without pressing another button, the window is scrolled vertically. Rotating with pressed SHIFT-key will scroll the window horizontally.

Are in the Topology window scrollbars present, the user can shift the window by pressing the middle mouse key.

By executing a mouse-click on a green line the "Link-Utilization" window is opened. The content of the window is updated dynamically and displays closer information about every single or CWDM fiber link between the Frames. The arrows are indicating the direction of the traffic. The color of the utilization-bar is separated in three groups:

1% to 50 %	green
51% to 75%	green ---> yellow
76% to 100%	yellow ---> red

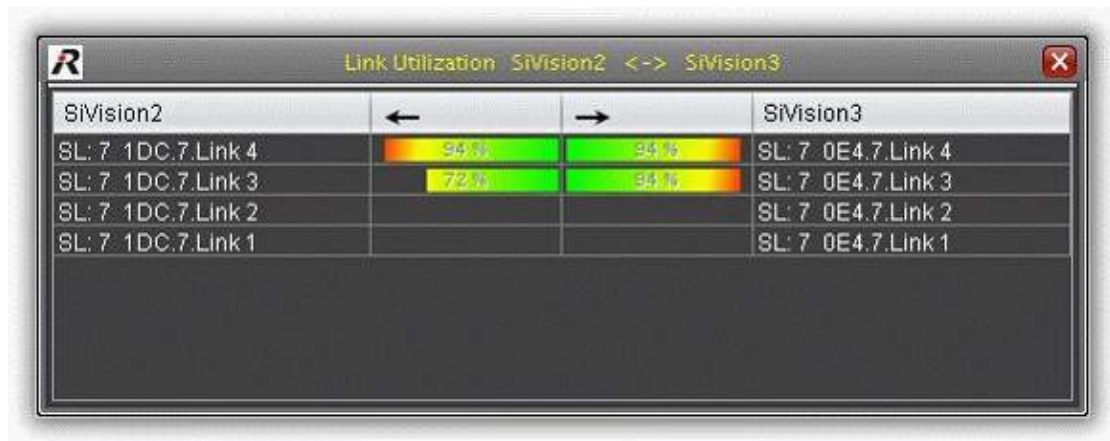

Figure 349: LINK UTILIZATION - window

USO RESTRITO

Following actions can be executed in the menu of the topology window:

- ▼ **Save Layout**
Positions of the Frames are stored. When the topology window is opened the next time, the Frames are restored to that position.
- ▼ **Layout Nodes (Small, Middle, Large)**
As long as the positions of the Frames are not stored, the positions are defined randomly. This feature will display the topology more clearly. The Frames are generally sorted like the white fields of a chessboard. The algorithm will identify certain topologies and arrange an ostensive overview.
- ▼ **Set Background Image / Remove Background Image**
This menu allows to load or to remove an individual background image. Supported formats are: gif, jpeg and png.
- ▼ **Reset Zoom**
Reset the zoom-ratio of the window to 1-
- ▼ **Close**
This command closes the topology window. The position of this window won't be saved.

5.8.4.8 Links

This window contains a summary of all links in the MediorNet network.

Next to the name (Channel A & B) is the optical power of the receiver and transmitter in dBm displayed. The blue line on the left-hand and right-hand side indicates the minimum and maximum receive power of the SFP. The white line is the actual receive power. These values are also displayed in a tooltip (see figure Link Overview).

A local-link-loop is given, when an output of a SFP is connected to the input of the same SFP. This case is indicated in the Link Overview in the respective row by a yellow cell background and red font.

The background of the RX area is green, when the received power is within the limits. The background is orange, when the difference between actual received power and the limit of the SFP is below 1 dBm. The background is red, when the limits of the SFP are exceeded.

The Links Usage (in %), the wavelength (in nm) and the distance between the Frames (in meters) is also displayed. An icon informs if the link is active or no longer present.

This window can be also opened by a context menu, which appears by right clicking on an empty area in MediorWorks.

Channel A	Rx dBm	Tx dBm	Usage %	Wave L. nm	Fram L. m	Link Up	Usage %	Tx dBm	Rx dBm	Channel B
125er10.Link.2	-6.8	-5.4	0%	850	0	●	0%	-5.4	-6.8	124er10.Link.0
125er10.Link.4	-5.4	-5.4	0%	850	0	●	0%	-5.4	-5.4	124er10.Link.1
125er7.Link.2	-7.2	-7.2	0%	850	1	●	0%	-5.6	-7.2	8FF.10.Link.3
125er7.Link.3	-7.2	-7.2	0%	1351	2	●	0%	-2.1	-7.2	8FF.10.Link.1
125er7.Link.4	-4.9	-4.9	0%	1310	3	●	0%	-4.4	-4.9	8FF.10.Link.4
800.7.Link.3	-5.4	-5.4	0%	850	1	●	0%	-5.4	-5.4	124er10.Link.2
800.7.Link.4	-5.4	-5.4	0%	850	3	●	0%	-4.3	-5.4	800.13.Link.2
800.10.Link.1	-5.4	-5.4	0%	850	3	●	0%	-5.4	-5.4	754.10.Link.1

Figure 350: Links

The values in this window are permanent updated.

The checked box *Hold Interrupted Links* shows also links, that are not present any more.

The font and the *Link Up* icon is changing to red. The font and the icon turning back to the default color, if the link is present again.

The text box in the top right corner lets the user search for specific Channel names A & B. Capitalization is ignored.

The order of the links can be changed by clicking on the column name.

USO RESTRITTO

5.8.5 3rd Party Interfaces

The MediorNet system is configurable via 3rd party interfaces. This is done via the ProBel SW-P-08 and/or the Ember+ protocol.

The following chapters explain the required setup to be able to maintain the system by external equipment.

The detailed description of the protocols are available in the respective Application Notes on the Riedel website ([Company > Services > Download > Download – Manuals & Application Notes](#)).

USO RESTRITO

5.8.5.1 Configuration

The window *3rd Party Configuration* is separated in two areas. A Split-Pane-Bar allows to change the proportion.

3rd Party Master(s)

One MediorNet Frame is responsible for the communication between the MediorNet Frames and the 3rd party controllers. The *3rd Party Configuration* allows the selection of a primary and secondary master Frame by checking the respective checkboxes. The connection needs to be established via the Config port of this Master.

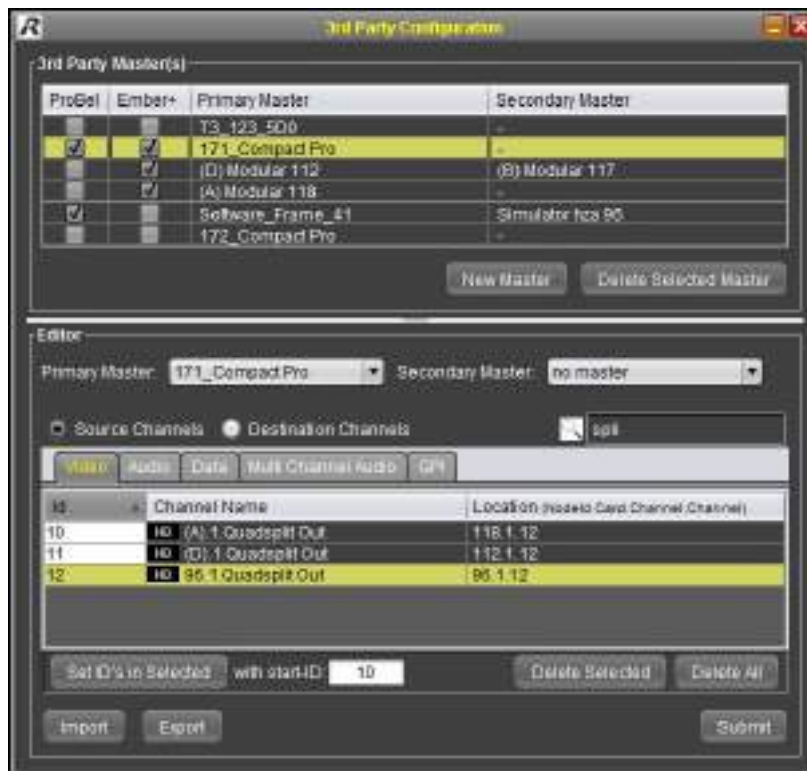

Figure 351: 3rd Party Configuration

The meanings of the different fields and buttons are described in the table below:

ProBel / Ember + Checkbox	ProBel / Ember+ Master enabling (changing takes place directly while set/delete the checkbox).
Primary / Secondary Master	Name of the primary / secondary Masters in the network (changes needs to be done in the Editor only).
New Master	Inserting a new row (the master(s) need to be selected in the Editor).
Delete Selected Master	The selected rows are deleted. If a primary or secondary Master is active (ProBel and/or Ember Checkbox is selected), the Master is deactivated. Also the configuration of the Master(s) will be deleted.

Editor

MediorNet can be operated via 3rd Party Controllers as a 65k x 65k Matrix. The IDs between 1001 and 1024 are reserved. The Sources and Destinations needs to be assigned to the IDs to be addressed by the protocol. The ID pool is in the range of 1 to 65535. The assignment must be performed separately for Video, Audio, Data, MADI/AES, and GPI.

The meanings of the different fields and buttons are described in the table below:

Primary Master	Selection of the primary master within a network.
Secondary Master	Selection of the secondary master within a network (only possible if a primary master is defined).
Source Channels	Selection of ID assignment of sources.
Destination Channels	Selection of ID assignment of destinations.
 Filter	Entered text is searched in the column <i>Channel Name</i> (case sensitivity is ignored).
Set ID's in selected	IDs are automatically assigned for the selected ports
with start-ID	start value, ID assigning will start from the next available ID
Delete Selected	Delete the assignment of selected ports
Delete All	Deletes all assignments
Import	Deletes the existing IDs and imports previous exported IDs.
Export	Export of assigned IDs.
Submit	Changes in the Editor takes place after pressing the button Submit.

USO RESTRITO

▼ Reserved IDs

The IDs 1001 to 1024 are special reserved by the MediorNet system and have the following meaning:

3rd Party ID	IDs on protocol layer	Meaning
1002	1001	Destination not connected
1003	1002	Delete connection
1004	1003	The connection to this destination is interrupted.
1005	1004	reserved for future use
1006	1005	A connection to this destination is present but the source doesn't have a valid ID.
1007	1006	reserved for future use
	to	
1024	1023	



Double assigned IDs are indicated by a red background. This may occur when: 1. f.i. ID1 is assigned to a Frame and this Frame is disconnected from the network. 2. ID1 is assigned again to another Frame in the network. 3. The previously disconnected Frame is reconnected to the network again. An Info-panel will pop up, if a user tries to assign an occupied ID.

USO RESTRITTO

5.8.5.2 SNMP-Server Activation

For accessing status information from the MediorNet system, an SNMP interface (Simple Network Management Protocol) on UDP/IP port 161 is available. This interface provides read-only access via the SNMPv2 protocol.

The button *Activate Selected* will enable the protocol on the selected Frame. *Deactivate selected* will disable the protocol.

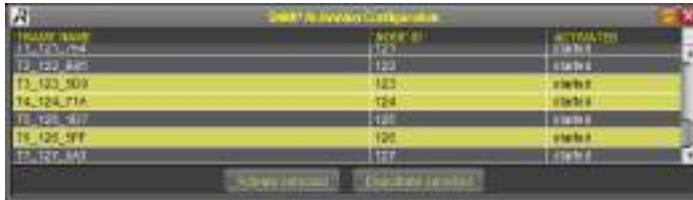

Figure 352: SNMP-Server Activation

▼ General SNMP information

MediorNet implements the SNMP v2c Standard.

The current MediorNet SNMP implementation can only be used for polling, no traps will be sent.

The currently implemented parameters are mainly switch parameters and information about all Cards of a Frame.

Overview of available parameters:

guid	temperature
name	cpuLoad
userNotes	psu1
packageVersion	psu2
contact	syncIn
location	syncOut
fanSpeed	syncState
slotTable	(cardName, cardStatus, cardTemperature, cardType)
linkTable	(linkStatus, inputUsage, outputUsage, linkCapacity, destGUID, destSlot, destLink)
videoPortTable	(portDirection, portName, portStatus, videoFormat, embAudio01-16)
gpiTable	(gpiDirection, gpiName, gpiStatus)

A slot information provided via SNMP could look like this:

Slot	name	status	temp	type
1	SNP00000000000000000000	OK	0	empty
2	SNP00000000000000000000	OK	0	empty
3	SNP00000000000000000000	OK	0	empty
4	SNP00000000000000000000	OK	0	empty
5	SNP00000000000000000000	OK	0	empty
6	SNP00000000000000000000	OK	0	empty
7	SNP00000000000000000000	OK	0	empty
8	SNP00000000000000000000	OK	0	empty
9	SNP00000000000000000000	OK	0	empty
10	SNP00000000000000000000	OK	0	empty
11	SNP00000000000000000000	OK	0	empty

Figure 353: SNMP-Example

USO RESTRITTO

The description of all found parameters, as shown in the screenshot above, can be found in the MediorNet MIB file. The SNMP MIB file stores important human readable information like available data and the data-format, which can be retrieved from a device.

Some of the parameters (actually extracted from the description in the MIB):

Parameter	Description
fanSpeed	The rotating speed of the fans of the current switch (RPM).
temperature	The temperature of the switch in degrees Celsius.
cpuLoad	Return CPU Load in per-mill for the last period of [5] seconds. Example: 500 would therefore mean a usage of 50%.
psu1	The operating status of power supply 1: 0 ... not available / 1 ... operating / 2 ... not operating

For further details it is recommended to study the MediorNet MIB file, which can be downloaded on the HTML site of the MediorNet Frame.

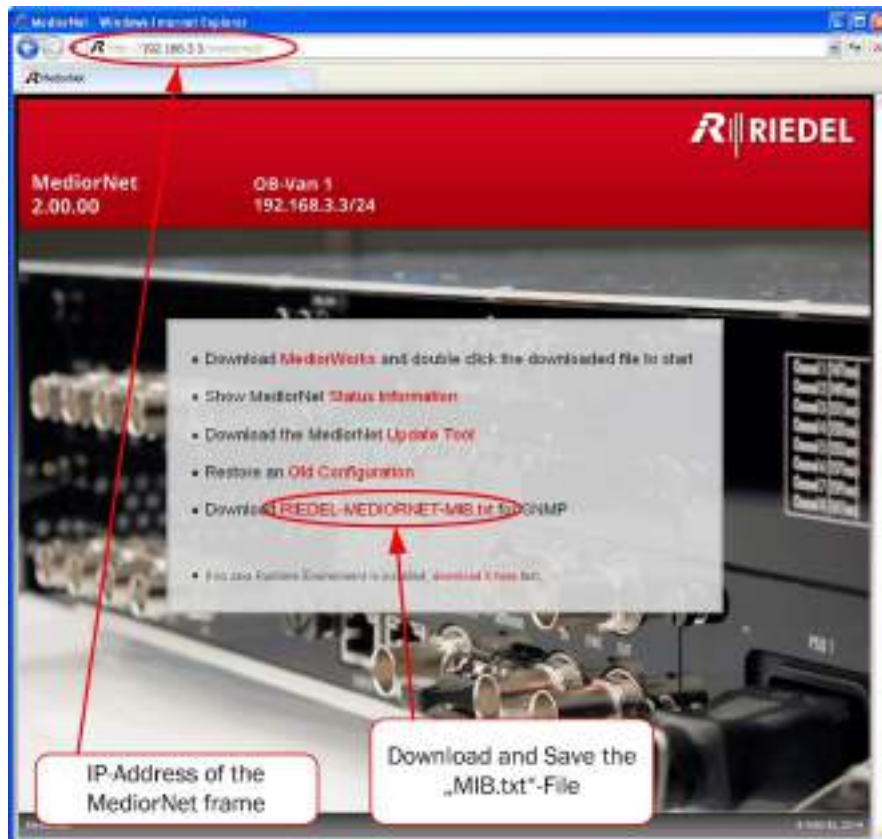

Figure 354: MIB-File

5.8.5.3 TSL Screen ID Overview

All Frames running a package version LATER than 1.6.x will have a TSL interface. MediorNet supports the TSL 5.0 UDP implementation.

Each Frame will act as a TSL 5.0 enabled device, running its own TSL server where 3rd party clients may connect to.

The TSL Server initializes an UDP socket on Port 9801 (default UDP UMD Port of the TSL TallyMan product). Each TSL Server is only responsible for any TSL-supported Video Channels on ITS OWN FRAME.

Currently only the multiviewer on the MN-HDP6 has TSL-supported Video channels.

The TSL Screen ID view shows you all TSL-enabled Video channels.

If your system has only one MN-HDP6 Card in slot 1 of the Frame your view might look like this:



Figure 355: TSL Screen ID Overview

The given TSL screen ID is needed to be able to set up 3rd party Software using the TSL Protocol appropriately.

For the screenshot above this would mean a TSL command setting a text for TSL Screen ID 268 sent to the IP 192.168.123.161 would result in the text of the 0A1.1.1.Quadsplit Out to be set.

USO RESTRITTO

▼ Details of the TSL implementation

The intended audience of the following details are 3rd party vendors and people familiar with the details of the TSL 5.0 UMD protocol which try to create an interface to MediorNet via the TSL interface.

Our TSL Server only accepts ASCII packets.

Unicode packets are rejected as well as Control packets, which are not defined in the TSL 5.0 standard.

Addressing scheme:

The scheme is designed to be able to address specific channels of any specific slot.

Each Channel can be a screen.

To set a certain text / tally information for a certain Channel the following addressing needs to be followed (Note on TSL Terminology):

Screen: A screen may have multiple Displays

Display: A display is the "real" target of any text/tally information

Of the screen ID the [Lil-Endian] MSB of Screen uint16 ID will be used as the slot of the Card

Of the screen ID the [Lil-Endian] LSB of Screen uint16 ID will be used as the Channel of the Card

▼ Addition to the protocol

In addition to the TSL protocol we send a reply:

A seven byte message with PCB (=5), VER, FLAGS, SCREEN of original packet and the seventh byte indicate if we could not parse/read/process.

```
( PRR_OK = 0 ,
  PRR_COULD_NOT_PARSE = 1 ,
  PRR_CONTROL_DATA = 2 ,
  PRR_UNICODE = 3 ,
  PRR_UNKNOWN_SCREEN = 4 ,
  PRR_ERROR = 5 ,
)
```

This extension to the protocol will not break functionality with any existing TSL Controller implementation but can provide ways of easily identifying lost packets as well as useful debugging information.

5.8.6 Help

Call the help information

5.8.6.1 Support Information

Shows the contact information.



Figure 356: Support Information

5.8.6.2 About ...

This command shows the following information:

- MediorWorks Software Version
- Java Version
- Version of PC's operation system



Figure 357: About ...

USO RESTRITO

5.9 Menus of MediorUpdate Software

In this chapter all MediorUpdate menus are listed in the order of appearance:

A checkbox *Select all frames* is visible in the main window.

Is the checkbox *Select all frames* checked, all actions are executed on all Frames. Single Frames can be selected by checking the checkbox *Update* in the respective row.

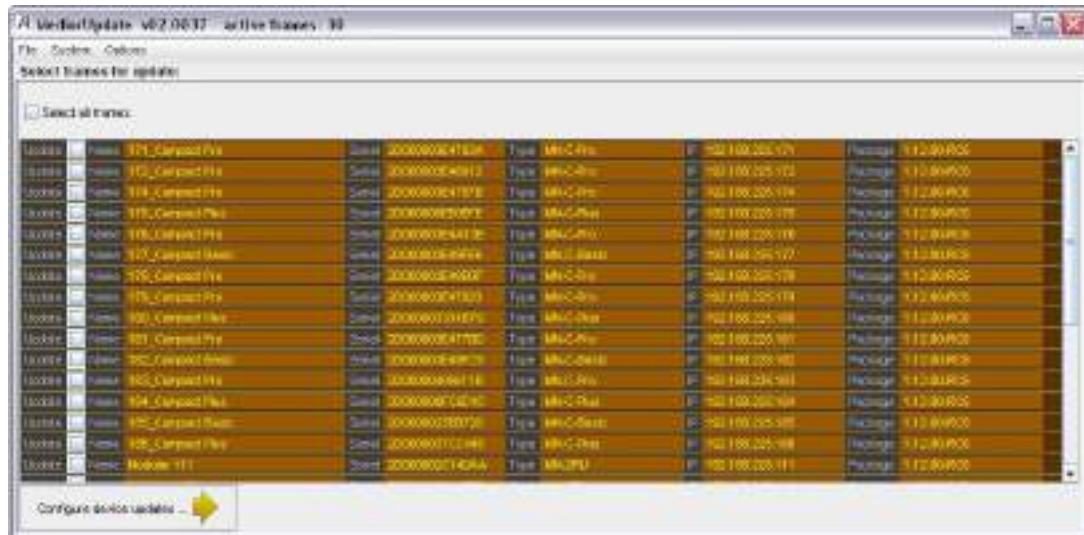

Figure 358: Update Frames

USO RESTRITTO

5.9.1 File

5.9.1.1 Exit

This command will close the MediorUpdate application.

5.9.2 System

5.9.2.1 Choose Network Interface

This command offers the same features like the [Configure Network Interface](#) command in MediorWorks.

5.9.2.2 Frame Address Properties

This command offers the same features like the [Frame Address Properties](#) command in MediorWorks, except the tab *Node ID Configuration* is not available in MediorUpdate.

5.9.2.3 Reboot/Restart Frames

This command offers the same features like the [Reboot/Restart Frames](#) command in MediorWorks.

5.9.2.4 Configure Service Handler

This command offers the same features like the [Configure Service Handler](#) command in MediorWorks.

5.9.3 Options

5.9.3.1 Expert Mode

If the checkbox *Expert Mode* is not checked, the selected frames are updated completely.

If the checkbox is checked, the user can select for each component separately, if the update should be performed. Furthermore the version can be determined for each component.

USO RESTRITO

6 Appendix

6.1 Technical Specifications

MediorNet-Modular

Supply Voltage	90 ... 264 VAC	Width	19" 483 mm
Frequency	47 ... 63Hz	Height	2 RU 88 mm
Power Consumption	150 VA / 2 A at 90 VAC	Depth	13" 330 mm
Environmental Temperature	-5° ... +40°C	Depth (incl. mounting ears)	16.3" 414 mm
Weight empty / incl. PSUs & FAN	3.7 kg / 5.1 kg		

MediorNet-Compact

Supply Voltage	100 ... 240 VAC 50 / 60 Hz	Width	19" 483 mm
	12 VDC ±10% max. ripple 250 mV / 20 MHz 8 A constant / 14 A peak (250 ms)	Height	3 RU 133 mm
Power Consumption	80 VA / 1A	Depth	9.5" 241 mm
Environmental Temperature	-5 ... +40 °C (Non-condensing)	Weight	8.2 kg

USO RESTRITTO

6.2 Glossary

Channel	Plug / Connector on a Card
CPLD	A programmable logic device (C omplex P rogrammable L ogic D evice)
Crosspoint	The virtual point intersection where a source is mixed and routed to a destination
CWDM	Technique for optical multiplexing of wavelengths (C oarse W avelength D ivision M ultiplexing)
De-Embedder	Excluding of Audio SubChannels out of a Video stream
Destination	Output Channel of the transported signal
DHCP	Service for automatic IP address assignment (D ynamic H ost C onfiguration P rotocol)
Embedder	Including of Audio SubChannels in a Video stream
Frame	A single MediorNet device
FPGA	An integrated circuit designed to be programmed by a customer (F ield- P rogrammable G ate A rray).
GUI	G raphical U ser I nterface
GUID	G lobally U nique I Dentifier
LC	Optical connector type (L ucent C onnecto r)
LTC	L ongitudinal T ime C ode
Matrix	View of sources and destinations in a matrix
Net	Complete local communication environment
OSD	O n S creen D isplay
PC	P ersonal C omputer
Port	Plug / Connector on a Card
PSU	P ower S upply U nit
Route	Connection between Frames to transport data from the source to the destination
SFP	S mall F orm-factor P luggable transceiver - extractable optical or electrical transmitter/receiver module
Slot	Position of the Cards in the MediorNet in the Frame (1 to 10)
Source	Input Channel of the signal to be transported
SubChannel	A signal embedded in a Channel
Sync Master	The Frame is the clock source for all attached Frames
Sync Slave	The Frame is synchronized to the clock of the Sync Master
VITC	V ertical I nterval T ime C ode

USO RESTRITO

6.3 Service

If you have any further questions, we offer comprehensive customer service options for this product including:

- Telephone Service
- Email Service
- Skype Service
- Fax Service
- Configuration Support
- Trainings
- Repair

Your primary point of contact for any service issues is your local dealer.
In addition, Riedel Customer Service in Wuppertal, Germany is also available to assist you.

Telephone: +49 (0) 202 292 9400
(Monday - Friday, 8am - 5pm, Central European Time)

Fax: +49 (0) 202 292 9419

Skype: riedel.communications.service

Or use the contact form on our website:

www.riedel.net > [Company](#) > [Riedel Communications](#) > [Contact](#) > [Wuppertal \(Headquarters\)](#)

For repairs, please contact your local dealer. Your dealer will be able to help process your repair as fast as possible and/or arrange for the delivery of spare parts.

The address for repairs sent directly to Riedel Communications GmbH is:

Riedel Communications GmbH & Co. KG
- Repairs -
Uellendahler Str. 353
D-42109 Wuppertal
Germany

Please add a completed repair form to all your repairs.

The form can be found at the Riedel website:

www.riedel.net > [Company](#) > [Services](#) > [Support](#) > [Contact](#)

USO RESTRITO

Notes

USO RESTRITO

Notes

USO RESTRITO

USO RESTRITTO