

# Solid-State Memory Camcorder

*PMW-F55*

*PMW-F5*

## Operating Instructions

Before operating the unit, please read this manual thoroughly and retain it for future reference.

**SxS****XAVC****HDMI****MPEG HD422**

# Table of Contents

---

## Overview

<b>Features</b> .....	<b>6</b>
<b>System Configuration</b> .....	<b>9</b>
<b>Location and Function of Parts</b> .....	<b>11</b>
<b>On-Screen Indications</b> .....	<b>17</b>
Sub Display Screen .....	17
Viewfinder Screen .....	20

---

## Preparations

<b>Power Supply</b> .....	<b>23</b>
Using a Battery Pack .....	23
Using AC Power (DC IN Power) .....	24
<b>Setting the Clock</b> .....	<b>24</b>
<b>Attaching Optional Devices</b> .....	<b>25</b>
Attaching a Lens .....	25
Attaching a Viewfinder .....	26
<b>Setting the Basic Action</b> .....	<b>27</b>
System Frequency .....	27
Shooting Mode .....	27
Main Recorded Signal .....	27
Color Space .....	28
Imager Scan Mode .....	28
Recording Format .....	28
<b>Using SxS Memory Cards</b> .....	<b>29</b>
About SxS Memory Cards .....	29
Inserting an SxS Memory Card .....	30
Removing an SxS memory card .....	30
Switching Between SxS Memory Cards .....	30
Formatting an SxS Memory Card .....	30
Checking the Remaining Time Available for Recording .....	31
Restoring an SxS Memory Card .....	31
<b>Using an SD Card</b> .....	<b>32</b>
Usable SD Cards .....	32
Inserting an SD Card .....	32
Removing an SD memory card .....	32
Formatting an SD Memory Card .....	32

Checking the Remaining Time .....	32
<b>Using an AXS-R5 .....</b>	<b>33</b>
Attaching the AXS-R5 .....	33
Removing the AXS-R5 .....	33
Inserting an AXS Memory Card .....	33
Removing an AXS Memory Card .....	34
Recording to an AXS Memory Card .....	34
Formatting an AXS Memory Card .....	34
Checking the Remaining Time Available for	
Recording .....	34
Restoring the AXS Memory Card .....	34
<b>Using a USB Wireless LAN Module .....</b>	<b>35</b>
Attaching the IFU-WLM3 .....	35
Making a Wi-Fi Connection .....	36
Using the Wi-Fi Remote Commander .....	36

---

## Recording

<b>Basic Operation Procedure .....</b>	<b>40</b>
<b>Changing Basic Settings .....</b>	<b>42</b>
Electronic Shutter .....	42
Sensitivity/Gain/Color Temperature/ White Balance .....	42
Audio .....	43
Time Data .....	43
<b>Useful Functions .....</b>	<b>43</b>
Assignable Buttons .....	43
Slow & Quick Motion .....	44
Recording Time-lapse Video (Interval Rec Function) .....	44
Starting to Record from Pre-stored Video (Picture Cache Function) .....	45
Simultaneously Recording .....	45
Rec Review .....	46
Focus Magnifier .....	46
False Color Display .....	46
Viewfinder Double Speed Drive Function .....	46

---

## Thumbnail Screens

<b>Thumbnail Screens</b> .....	<b>47</b>
Configuration of the Screen .....	47
<b>Playing Clips</b> .....	<b>48</b>
Playing the Selected and Subsequent Clips in Sequence .....	48
<b>Clip Operations</b> .....	<b>48</b>
Operations of the Thumbnail Menu .....	48
Displaying the Detailed Information of a Clip .....	49
Copying MPEG2 Proxy Data (PMW-F55 only) .....	49
Deleting Clips .....	50
Changing Information on the Thumbnail Screen .....	50

---

## Settings

<b>Sub Display Operation</b> .....	<b>51</b>
<b>Sub Display Setting Items</b> .....	<b>52</b>
CAMERA Screen .....	52
FILE Screen .....	53
AU/TC (audio/timecode) Screen .....	54
<b>Setup Menu Operations</b> .....	<b>56</b>
User Menu .....	57
<b>Setup Menu List</b> .....	<b>59</b>
Camera Menu .....	59
Paint Menu .....	68
Audio Menu .....	73
Video Menu .....	77
VF Menu .....	80
TC/UB Menu .....	83
Recording Menu .....	84
Media Menu .....	85
File Menu .....	86
Maintenance Menu .....	89
System Menu .....	90

---

## External Devices Connection

<b>Connecting External Monitors and Recording Devices</b> .....	<b>96</b>
<b>Operating Clips With a Computer</b> .....	<b>97</b>
<b>External Synchronization</b> .....	<b>98</b>

<b>Important Notes on Operation .....</b>	<b>99</b>
<b>Formats and Limitations of Outputs .....</b>	<b>101</b>
Video Formats and Output Signals .....	101
<b>Error/Warning Indications .....</b>	<b>109</b>
Error Indications .....	109
Warning Indications .....	109
Caution and Operation Confirmation Indications .....	110
<b>Items Saved in the File .....</b>	<b>112</b>
<b>Licenses .....</b>	<b>120</b>
MPEG-2 Video Patent Portfolio License .....	120
MPEG-4 Visual Patent Portfolio License .....	120
MPEG-4 AVC Patent Portfolio License .....	120
On accessing software to which the GPL/LGPL applies .....	121
Open software licenses .....	121
<b>Specifications .....</b>	<b>121</b>
General .....	121
Camera Section .....	123
Input/Output .....	124
Media .....	124
Package Configuration .....	124
Optional Accessories .....	125
<b>Index .....</b>	<b>128</b>

## Overview

# Features

The PMW-F55/F5 is a highly compact, lightweight and high-performance CineAlta 4K camera with a 4K Super 35mm equivalent Single-chip CMOS image sensor.

The PMW-F55's CMOS image sensor with frame image scan function allows you to shoot clear 4K images without rolling shutter distortion or flash band phenomenon, for perfect HD recording performance.

The PMW-F5's 4K image sensor allows you to record high quality HD pictures. You can record in SR SStP/MPEG2 HD video format, in addition to the new 4K-compatible format, XAVC, by using an SxS memory card. 4K RAW data can be recorded by using the portable memory recorder, AXS-R5, which adopts the newly developed access memory card (AXSM).

The camcorder adopts the same native FZ mount used by the PMW-F3. You can use a variety of cine lenses (PL mount) so that the PL/FZ conversion adaptor comes standard.

By using the optional LA-FZB1/LA-FZB2 mount adapter, the B4 lens that is widely used for broadcasting can be attached. You can use your lens libraries with this camcorder.

### Compatible with multi format

The camcorder is compatible with the new format, XAVC (official name: MPEG4 AVC/H.264 Hi422 Profiles/Level 5.2), and can record 4K: 4096 × 2160, QFHD: 3840 × 2160, 2K: 2048 × 1080, HD: 1920 × 1080.

The camcorder is also compatible with frame rates from 23.98P to 59.94P. For high-speed shooting, you can record 1 fps to 60 fps for XAVC recording in the S & Q mode. The recommended media for XAVC recording is the newly developed SxS PRO+ memory card. The camcorder is also compatible with SStP SR-SQ 444, SR-SQ 422, and SR-Lite 422 that are adopted for HDCAM-SR, or MPEG2 HD 422 that is adopted for XDCAM. Your workflow can be used.

If you install the CBK-55PD to the PMW-F55/F5, you can record in the Apple ProRes and Avid DNxHD® codec.

### High frame rate (HFR) recording with up to 240 FPS

Using the camcorder with the AXS-R5 allows you to perform 2K RAW recording with up to 240 FPS.

You can use 2K/HD to record up to 180 FPS to the SxS memory card on the camcorder without the AXS-R5.

The camcorder has two scan modes for high frame rate. In the first mode, you can shoot with the full angle of the CMOS image sensor equivalent to the Super 35 mm size, and use the lens with the focal length set for normal shooting of high frame rate recording.

In the second mode, you can shoot with the center area of the CMOS image sensor equivalent to the Super 35 mm size (cut to Super 16 mm size).

### Modular structure

The camcorder incorporates a modular design that allows you to configure the camcorder according to shooting circumstances, whether for cinema production, drama, commercials, 3D shooting, documentary filming, interviews, etc. The handle, viewfinder, audio connector panel, RAW recorder, and build up kit can be attached/removed easily according to shooting requirements.

The body and handle of the camcorder have multiple 1/4" and 3/8" mount points, to which you can attach standard accessories.

### Other features

#### 4K Super 35mm equivalent CMOS image sensor

The camcorder has a 4K Super 35mm equivalent Single-chip CMOS image sensor of 11,600,000 pixels, with effective pixels count of 8,900,000, for 4K/HD recording.

The CMOS image sensor of the PMW-F55 includes a frame image scan function that allows you to shoot clear images without rolling shutter distortion or flash band phenomenon that occurs with a traditional film camera. The camcorder adopts a color filter that emphasizes color reproduction compatible with wide color area

(exceeding that of color film), allowing for near human vision image representation capability.

### Wide latitude, low noise

The camcorder has a 14-stop latitude that can reproduce images captured by the CMOS sensor with smooth gradation of black to white.

Exmor Super35 CMOS technology provides low noise levels, even with 4K resolution and 14-stop latitude maintained.

### A wide variety of recording functions

The camcorder has the Interval Rec function that allows you to record frames specified at regular intervals and the Cache Rec function that allows you to begin recording a specified number of seconds in advance of the time that can be used for variety of situations.

### Video signal processing

4K/HD simultaneous recording and high-speed recording with unlimited recording time is possible with single LSI chip processing of both camera signals and baseband video signals. Single-chip design provides stable, high-speed 4K 59.94P baseband video processing, low power consumption, and compact design.

### Gamma curves corresponding to various situations

The camcorder has a variety of gamma curves corresponding to various situations.

S-Log2 and S-Log3 are equipped to cover wide latitude of the camcorder.

The camcorder also has user gamma and hyper gamma.

The user gamma can install and use the gamma curve that is made by CvpFileEditor™ V4.2.

The hyper gamma can display the wide dynamic range images in smooth contrast without using the knee function. The PMW-F55/F5 provides the following six hyper gamma choices:

### Available hyper gamma choices

No.	Name*	Dynamic range	White limit	Video output with 18% gray card (video input 20%)
1	HG3250G36	325%	100%	36%
2	HG4600G30	460%	100%	30%
3	HG3259G40	325%	109%	40%
4	HG4609G33	460%	109%	33%
7	HG8009G40	800%	109%	40%
8	HG8009G33	800%	109%	33%

\* Name format: "HG" + 3 digits of dynamic range value + the unit digit of white limit + "G" + video output value with 18% gray card

You can select dynamic range from among 325%, 460%, and 800%. You can select 109% or 100% for the maximum value of video output (White Limit). You can select the video output value with 18% gray card from two values.

### Monitor LUT on/off function for each output

By dividing the video output signal (including the internal recorded signal) into 3 types, you can set Monitor LUT to on/off for each type independently.

The camcorder has 5 types of gamma curve and 4 types of Look Profile for Monitor LUT preset.

You can also use any user LUT file that is created by RAW Viewer.

### Intuitive user interface

This camcorder has the color LCD panel on the inside panel, and direct access menu that assigns the commonly-used settings to 6 buttons.

Displaying the setting information large, makes visibility better.

By switching four screens (CAMERA, FILE, AU/TC, VIEW), you can perform setting speedy. A LOCK switch allows you to prevent changing settings by accident.

By using the supplied IFU-WLM3 USB wireless LAN module, you can operate the camcorder from a Wi-Fi compatible device such as a tablet, with the wireless transmission.

### Assignable buttons

The inside panel has three assignable buttons, while the outside panel has one assignable button. You can operate the camcorder easily by assigning commonly-used functions to these buttons.

### Built-in ND filter

A rotary ND filter is built into the camcorder, and supports three types of filter: Clear, 0.9 (1/8), and 1.8 (1/64). This allows light adjustment without the need for external matte box.

When using a B4 lens by attaching an optional LA-FZB2 mount adapter to the camcorder, you can use the power optical filter (neutral density filter and color temperature conversion filter) of the LA-FZB2 by setting the built-in ND filter of the camcorder to "Clear."

---

## Various input/output connectors

---

### Four types of SDI output

The camcorder has four types of SDI output that allows you to output 4K 59.94P signal as four 3G-SDI.

The SDI-1/2 and SDI-3/4 outputs are assignable as SDI-1/2 OUT to Main, and SDI-3/4 OUT to Sub.

The camcorder also includes connections for Genlock IN, Timecode IN/OUT, HDMI OUT, Remote.

---

### EFP-Style build up kit

---

Attaching the accessory kit CBK-55BK to the camcorder improves stability and operability of the shoulder camcorder style.

The CBK-55BK has various audio input/output connectors, direct switches that allow you to control the camcorder on hand while looking through the viewfinder when shooting with the camcorder on your shoulder, wireless audio receiver slot, and audio control panel.

The front control section and shoulder pad can be slid 70 mm (2 <sup>7</sup>/<sub>8</sub> inches) in the front-to-rear direction. You can maintain balance easily while shooting with the camcorder on your shoulder when the PL lens or large portable B4 lens is attached.

---

### 4K upgrade license for PMW-F5

---

By installing the CBKZ-55FX to the PMW-F5, 4K recording/playback for XAVC 4K/QFHD and 4K/QFHD output from SDI and HDMI are available.



# System Configuration

This section shows examples of the camera system configuration.



Viewfinder  
DVF-L350

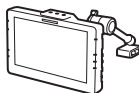

Viewfinder  
DVF-L700

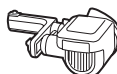

Viewfinder  
DVF-EL100



Microphone  
ECM-680S (EC-0.5X5F3M), ECM-678, ECM-674

### Lenses

PMW-F3K supplied lenses (35 mm/50 mm/85mm)  
 SCL-PK6/F, PK6/M (set of 6 lenses, 20 mm/25 mm/35 mm/50 mm/85 mm/135 mm)  
 SCL-PK3/F, PK3/M (set of 3 lenses, 20 mm/25 mm/135 mm)  
 SCL-P11X15  
 SCL-Z18X140

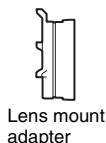

Lens mount  
adapter



Mount adapter  
LA-FZB1, LA-FZB2

Optical 2K Filter  
CBK-55F2K



Remote control unit  
RM-B170, RM-B750, CBK-DCB01

USB wireless LAN module  
IFU-WLM3 (supplied)

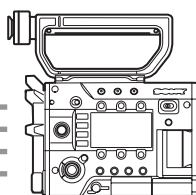

PMW-F55, PMW-F5

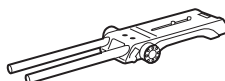

Shoulder adaptor  
VCT-FSA5

Additional codec board  
CBK-55PD

4K upgrade license (for PMW-F5)  
CBKZ-55FX

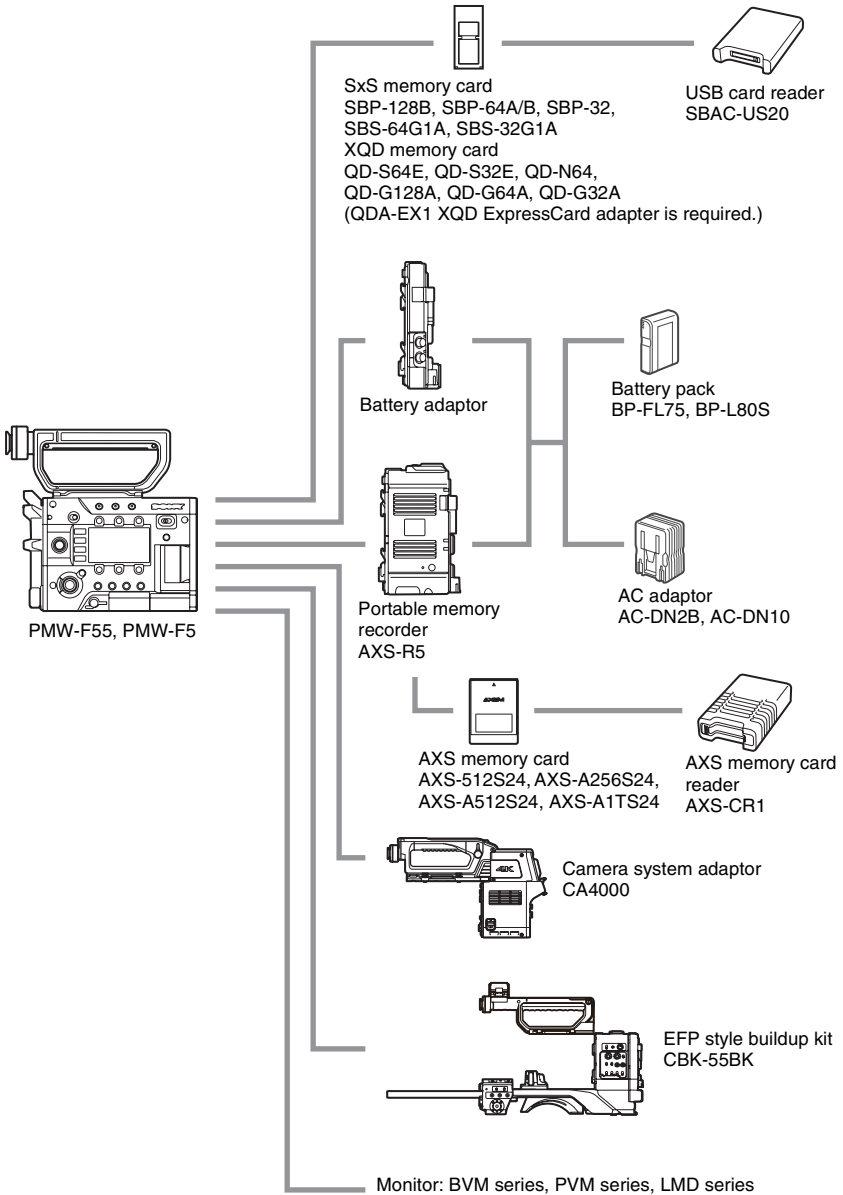

# Location and Function of Parts

For functions and usage, see the pages in parentheses.

The following illustrations are with the battery adaptor (page 16) removed.  
For removing the battery adaptor, see “Removing a battery pack” (page 23).

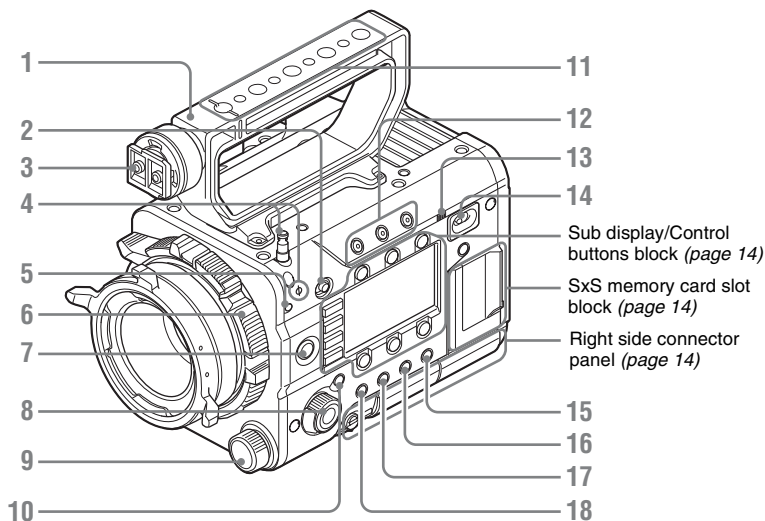

## 1. Handle

## 2. LOCK switch

Disables operations on the side operating panel.

## 3. Viewfinder shoe

## 4. Tape measure hook/Image sensor position index

The  $\Phi$  mark and tape measure hook are on a plane with the image sensor. To measure the precise distance between the camcorder and the subject, use this mark or tape measure hook as a reference.

You can attach the end of a tape measure to the hook, and measure the distance from the subject.

## 5. Flange focal length adjustment screw (page 26)

## 6. Lens mount (page 25)

## 7. REC (recording start/stop) button/lamp (page 40)

## 8. SEL/SET (select/set) dial (MENU dial) (pages 51, 56)

Selects the item in the menu or changes the setting value.

## 9. ND FILTER select switch

ND filters are available for keeping the aperture in a proper range.

Select the ND filter by turning the ND FILTER select switch while pulling it.

**Clear:** ND filter not used

**0.9:**  $1/8$ ND

**1.8:**  $1/64$ ND

## 10. CANCEL/BACK button (pages 51, 56)

## 11. Accessory mounting screw holes

Type of screw: 1/4-20UNC (× 4)

Type of screw: 3/8-16UNC (× 5)

Length of engagement: 9 mm ( $3/8$  inch) or less

### Note

Do not apply excessive force to the mounted accessory. It may damage the screw thread.

## 12. ASSIGN (assignable) 1/2/3 buttons (page 43)

## 13. Built-in speaker (page 40)

## 14. Power switch

Set to the ON position (I) to turn the power on. Set to the OFF position (⏻) to turn the power off.

### Notes

- This camcorder uses a small amount of standby power even when the power switch is set to OFF. Remove the battery pack if the camcorder will not be used for a prolonged period.
- When removing the battery pack or the DC IN power, be sure to first set the power switch to the OFF position. Removing the battery pack or the DC IN power while the camcorder is ON may cause damage to the camcorder or the memory card.

## 15. BRIGHTNESS button

Adjusts brightness of the sub display in 4 steps.

## 16. STATUS (status display on/off) button

Displays status screens on the viewfinder or external video monitor.

Turn the MENU dial (*page 11*) to switch the screens in sequence.

### Tip

Items in [ ] are displayed when the CBK-55BK is attached.

### Camera status screen

Displays the electronic shutter settings or the status of the lens.

Gain	Amount of gain up (dB) or sensitivity (ISO-EI)
Shutter	Electronic shutter settings
Gamma	Gamma category and curve (When "Shooting Mode" is set to "Cine EI," Gamma for MLUT Off is displayed.)
White	White balance mode and setting
Zebra1	On/off and setting level of Zebra1
Zebra2	On/off and setting level of Zebra2
[Gain/EI Switch <L>]	Setting level of the gain switch L on the CBK-55BK
[Gain/EI Switch <M>]	Setting level of the gain switch M on the CBK-55BK
[Gain/EI Switch <H>]	Setting level of the gain switch H on the CBK-55BK
Iris	T value of iris
Focal Length	Focal length (mm)
Focus Distance	Focus distance (m/feet)
Depth Of Field	Depth of field (m/feet)
Optical Filter	Type of optical filter

## Audio status screen

Displays the input settings for each channel, audio level meter, and wind filter setting.

Level	Level meter
Source	Input source
Reference	Reference level setting
Wind Filter	Wind filter setting

## System status screen

Displays the video signal settings.

System Frequency	System frequency
Rec Format	Recording format that is recorded on the SxS memory card
Picture Size	Picture size that is recorded on an SxS memory card
Rec Function	Special recording that is set to on, and its setting
Gamma	Gamma category that is recorded on the SxS memory card
Imager Scan	Imager reading mode
Picture Cache Rec	On/off setting of Picture Cache Rec
MPEG2 Proxy	On/off setting of MPEG2 proxy (PMW-F55 and PMW-F5 + CBKZ-55FX)
Option	Attached option

## Video output status screen

Displays the video output settings of SDI 1 to SDI 4, HDMI, and test video output.

Picture size	Output picture size
C.Space	Output form
Freq	Output rate
Gamma	Gamma

## Assignable button status screen

Displays the function that is assigned to each ASSIGN button.

1 to 4 ([5] to [8]), Lens RET	Functions that are assigned to the Assign 1 to 4 ([5] to [8]) buttons and RET button on a lens
Menu Dial Assign	Functions that are assigned to the Menu dial

## Battery status screen

Displays information of the battery or DC IN power.

Detected Battery	Battery type
Remaining	Remaining charge level (%)
Charge Count	Number of times that the battery is charged
Capacity	Remaining capacity (Ah)

Voltage	Voltage (V)
Manufacture Date	Manufacture date of the battery
Power Source	Power source
Supplied Voltage	Supplied voltage

### Media status screen

Displays the remaining space, available recording time, and estimated service life of the recording media (SxS memory card A/SxS memory card B/SD card/AXS memory).

Protect information	
Remaining	Remaining space and available recording time
Life	Estimated service life

### 17. OPTION button (page 48)

### 18. MENU (menu display on/off) button (page 56)

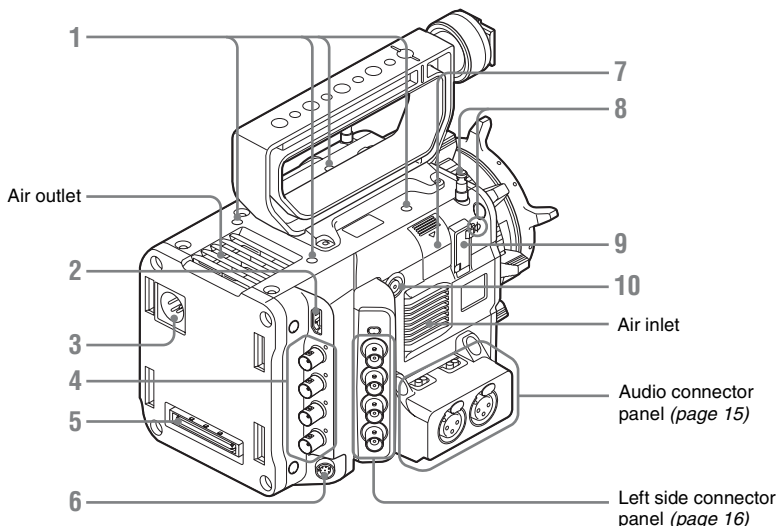

### 1. Accessory mounting screw holes

Type of screw: 1/4-20UNC (× 4)

Length of engagement: 9 mm  
(<sup>3</sup>/<sub>8</sub> inch) or less

#### Notes

- Do not apply excessive force to the mounted accessory. It may damage the screw thread.
- When attaching an accessory, do not cover the air inlet or air outlet.

### 2. HDMI OUT connector (page 96)

### 3. DC IN connector (page 24)

### 4. SDI OUT 1 to 4 (serial digital output) connectors (BNC type) (page 96)

### 5. Mounting terminal for an expansion unit (pages 23, 33)

### 6. REMOTE (remote control) connector (8-pin)

Connect an external device such as a remote control unit.

### 7. USB wireless LAN module retracting part (page 35)

Connecting the supplied IFU-WLM3 USB wireless LAN module allows communication with wireless LAN devices.

### 8. Tape measure hook/Image sensor position index

The mark  $\phi$  and tape measure hook are on a plane with the image sensor. To measure the precise distance between the camcorder and the subject, use this mark or tape measure hook as a reference.

You can attach the end of a tape measure to the hook, and measure the distance from the subject.

### 9. VF (viewfinder output) connector (page 26)

### 10. ASSIGN 4 (assignable 4) button (page 43)

## Sub display/Control buttons block (page 51)

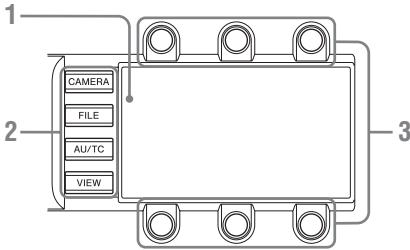

1. Sub display
2. Function buttons
  - CAMERA button
  - FILE button
  - AU/TC (audio/time code) button
  - VIEW button
3. Item button

## SxS memory card slot block (page 29)

The SxS memory card slots are located behind the cover.

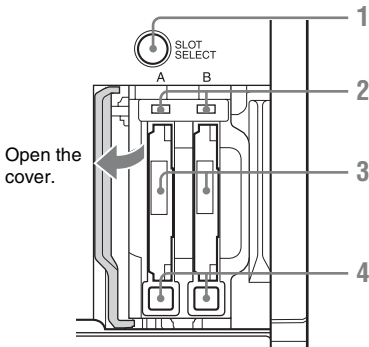

1. SLOT SELECT (SxS memory card select) button
2. ACCESS (SxS memory card access) lamps
3. SxS memory card slots
4. EJECT (SxS memory card eject) buttons

## Right side connector panel

The USB connector and SD card slot are located behind the cover.

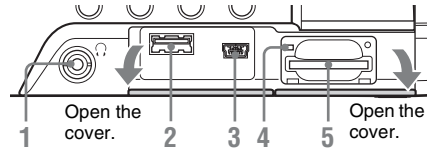

1. Headphones connector (stereo mini jack) (page 40)
2. USB connector (A)
3. USB connector (Mini B)
4. ACCESS (SD card access) lamp (page 32)
5. SD card slot (page 32)

## Audio connector panel

Attach the supplied audio connector panel as follows.

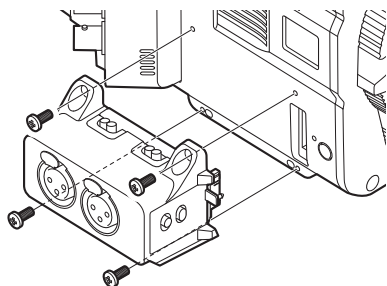

### Notes

- Attach/remove the audio connector panel while the camcorder is turned off.
- When attaching the audio connector panel, make sure not to catch the cap.
- When removing the audio connector panel, pull it away slowly from the body of the camcorder, as shown in the diagram above.
- Applying excessive force to remove the audio connector panel may damage it.

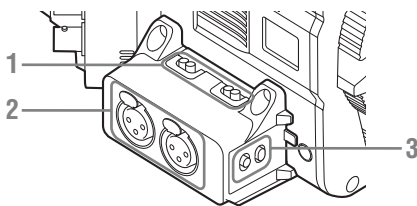

### 1. AUDIO IN CH1/AUDIO IN CH2

**(external audio input selection) switches**  
Switch input signal (external microphone, external audio device, etc.).

**LINE:** Line input audio equipment

**AES/EBU:** AES/EBU format audio signal

**MIC:** Microphone input

### 2. AUDIO IN (CH-1, CH-1/2) /AUDIO IN (CH-2, CH-3/4) connectors

Input external microphone or audio equipment signals.

### 3. CH1 MIC +48V/OFF, CH2 MIC +48V/OFF (external microphone input selection) switches

Supply phantom power (48 V) to the external microphone when you set this switch to "MIC +48V."

Settings of the AUDIO IN CH1/AUDIO IN CH2 switch and recorded channels are as below.

AUDIO IN CH1/CH2 switch		Recorded channel			
CH-1	CH-2	CH-1	CH-2	CH-3	CH-4
LINE/MIC	LINE/MIC	LINE1/MIC1	LINE2/MIC2	No sound	No sound
AES/EBU	LINE/MIC	AES/EBU1-1	AES/EBU1-2	No sound	No sound
LINE/MIC	AES/EBU	LINE1/MIC1	No sound	AES/EBU2-1	AES/EBU2-2
AES/EBU	AES/EBU	AES/EBU1-1	AES/EBU1-2	AES/EBU2-1	AES/EBU2-2

LINE1/MIC1: LINE or MIC signal that is input to CH-1

LINE2/MIC2: LINE or MIC signal that is input to CH-2

AES/EBU1-x: Channel x signal of the AES/EBU signal that is input to CH-1

AES/EBU2-x: Channel x signal of the AES/EBU signal that is input to CH-2

## Left side connector panel

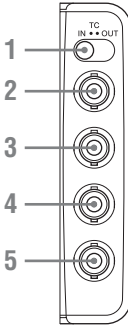

1. TC IN/OUT (timecode input/output selection) switch (page 98)
2. TC (timecode input/output) connector (BNC type) (page 98)
3. GENLOCK IN connector (BNC type) (page 98)
4. TEST OUT (analog video output) connector (BNC type) (page 96)
5. SHUTTER connector (BNC type)  
Not used for this version.

## Bottom

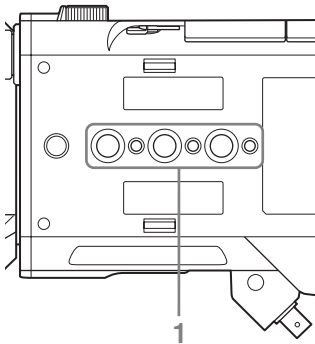

1. Accessory mounting screw holes  
Type of screw: 1/4-20UNC (× 3)  
Type of screw: 3/8-16UNC (× 3)  
Length of engagement: 9 mm  
(<sup>3</sup>/<sub>8</sub> inch) or less

### Note

Do not apply excessive force to the mounted accessory. It may damage the screw thread.

## Battery adaptor

For attaching/removing the battery adaptor, see “Using a Battery Pack” (page 23).

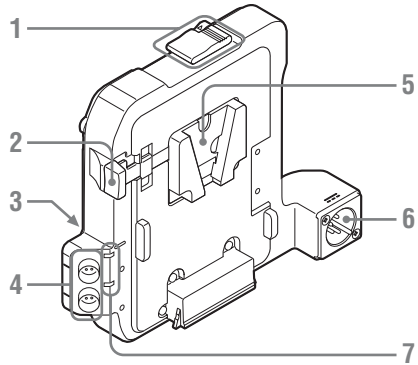

1. Release button/ejection lever
2. Battery release lever
3. Expansion IF connector
4. DC OUT 1/2 connector

### Note

When connecting a device, use one with current consumption of 1.8 A or less.

5. Battery pack attaching part
6. DC IN connector (page 24)
7. DC OUT overcurrent indicator

Lights when the overcurrent protection activates.

In this case, disconnect any peripheral device from a DC OUT connector whose indicator is lit, then restart the PMW-F55/F5.



# On-Screen Indications

## Sub Display Screen

When turning on the camcorder, the sub display appears and you can check the status of the camcorder and set the basic items.

The screen is switched by pressing the function button on the left of the sub display (*page 14*).

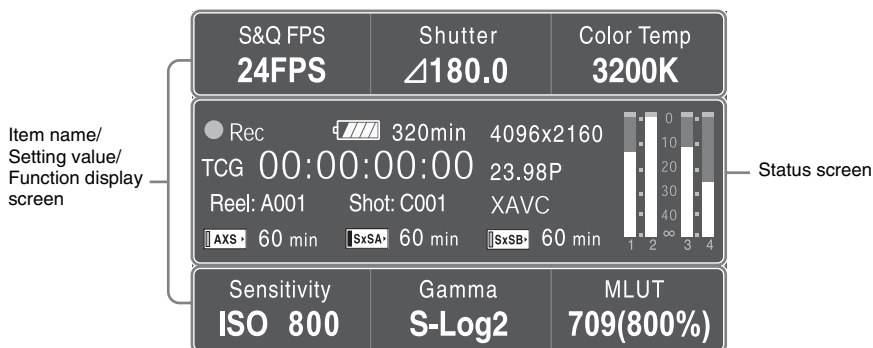

### Item name/Setting value/Function display screen

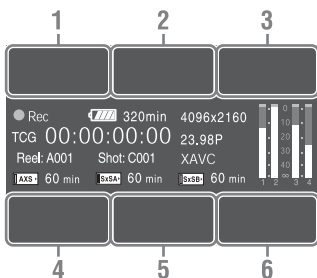

#### CAMERA-1 (*page 52*)

- 1. S&Q FPS**  
Displays and sets Slow & Quick Motion/Frame Rate.
- 2. Shutter**  
Displays and sets shutter speed/angle.
- 3. Color Temp**  
Displays and sets color temperature.
- 4. Sensitivity/Gain/Exposure Index**  
Displays and sets sensitivity/gain (ISO/dB/EI).

#### 5. Gamma/High Latitude

Displays and sets gamma category.  
(When “Shooting Mode” (*page 90*) is set to “Cine EI,” “High Latitude” is displayed.)

#### 6. MLUT

Displays and sets monitor LUT/Look Profile.  
The MLUT indication appears only when “Shooting Mode” (*page 90*) is set to “Cine EI.”

#### CAMERA-2 (*page 53*)

- 1. Color Bars**  
Turns the color bars on/off.
- 2. Auto White**  
Performs the auto white balance function.
- 3. Auto Black**  
Performs the auto black balance function.
- 4. Sub&HDMI**  
Turns the Monitor LUT of SDI (Sub) and HDMI output on/off.
- 5. Viewfinder**  
Turns the Monitor LUT of viewfinder output on/off.

**6. SDI (Sub) Disp.**

Turns the function that outputs the character information to the SDI (Sub) output on/off.

**FILE-1 (page 53)****1. to 6. All File Load 1 to 6**

Loads the All file (1 to 6) from the SD card.

**FILE-2 (page 53)****1. to 6. Scene Recall 1 to 5/Standard**

Loads the Scene file (1 to 5, or Standard) from the internal memory.

**FILE-3 (page 54)****1. to 6. Lens Recall 1 to 6**

Loads the Lens file (1 to 6) from the internal memory.

**AU/TC-1 (page 54)****1. MIC CH1 Ref**

Displays/sets the reference input level for MIC CH1.

**2. CH1 Input**

Sets Auto/Manual for the recording level of CH1, and displays/sets the level for Manual setting.

**3. CH1 Select**

Displays the input source for CH1.

**4. MIC CH2 Ref**

Displays/sets the reference input level for MIC CH2.

**5. CH2 Input**

Sets Auto/Manual for the recording level of CH2, and displays/sets the level for Manual setting.

**6. CH2 Select**

Displays the input source for CH2.

**AU/TC-2 (page 55)****3. Monitor CH**

Displays/sets the audio channel that is output to the headphones and speaker.

**5. Monitor Level**

Displays/sets the monitor volume that is output to the headphones and speaker.

**AU/TC-3 (page 55)****1. Display**

Displays/sets the time data.

**2. Reset**

Resets the timecode and counter.

**3. Set**

Sets the timecode.

**4. Mode**

Sets the timecode mode.

**5. Run**

Sets the condition for the timecode.

**6. TC Source**

Displays the external lock status for the timecode.

**VIEW-1****1. F Rev ◀◀**

Fast reverse

**2. Play/Pause ▶▶**

Play/pause

**3. F Fwd ▶▶**

Fast forward

**4. Prev ◀◀**

Previous clip jump

**5. Stop ■**

Stop

**6. Next ▶▶**

Clip directional jump

**VIEW-2****1. Thumbnail **

Displays or cancels the display of the thumbnail screen.

**2. Up ↑**

Moves the cursor up.

**3. Set -⏏-**

Confirms the selected item.

**4. Left ←**

Moves the cursor to the left.

**5. Down ↓**

Moves the cursor down.

**6. Right →**

Moves the cursor to the right.

## Status screen

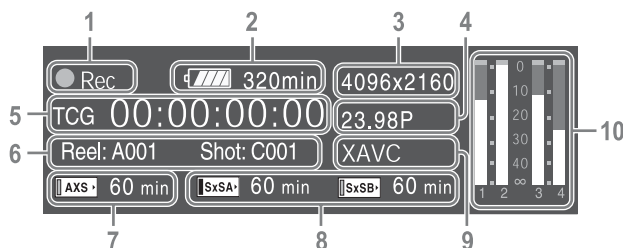

### 1. Special recording/operation status indication

● Rec	Recording in progress
● Stby	Standby for recording
● S&Q Rec	Slow & Quick Motion recording in progress
● S&Q Stby	Standby for Slow & Quick Motion recording
● HFR Rec	Slow & Quick Motion and Hi Frame Rate mode recording in progress
● HFR Stby	Standby for Slow & Quick Motion and Hi Frame Rate mode recording
● Int Rec	Recording in progress in Interval Rec mode
● Int Stby	Standby for Interval Rec recording
● Int Stby	Waiting for Interval Rec picture capturing
● Cache	<ul style="list-style-type: none"> <li>● lights in green: Standby for Picture Cache Rec mode</li> <li>● lights in red: Recording in progress in Picture Cache Rec mode</li> </ul>

### 2. Battery remaining charge/DC IN voltage indication (page 24)

### 3. Recording format (picture size) indication (page 28)

Displays the picture size that is recorded on an SxS memory card.

### 4. System frequency and scan method indication (page 27)

### 5. Time data indication (page 43)

### 6. Clip name indication (page 85)

While recording:

Displays “Clip: clip name” when “Mode” in “Clip Naming” of the Media menu is set to “Title,” or “Reel: Camera ID + Reel Number” and “Shot: Camera Position + Shot Number” when “Mode” in “Clip Naming” of the Media menu is set to “Cam ID + Reel#.”

While playing/displaying the thumbnail screen:

Displays “Clip: clip name.”

### 7. AXS memory status/remaining space indication (page 34)

### 8. A/B slot media status/remaining space indication (page 31)

### 9. Recording format (codec) indication (page 28)

Displays the format that is recorded on an SxS memory card.

### 10. Audio level meter (4CH)

## Viewfinder Screen

While recording, standing by to record, or playback, the statuses and settings of this unit are superimposed on the viewfinder screen.

The statuses and settings of this unit can be turned on/off using the setup menu or by the assignable button. The statuses and settings of this unit can be independently turned on/off (page 82).

### To turn on/off on the setup menu

Turn on/off the statuses and settings of this unit on “Setting” in “Display On/Off” (page 82) of the VF menu.

### To turn on/off by the assignable button

Assign “Display” to one of the assignable buttons (page 43). You can turn on/off the statuses and settings of this unit by pressing the assignable button.

**Tip**

When using the 1.3× or 2× anamorphic lens, set “Aspect” in “VF Setting” (page 80) of the VF menu to “Anamo ×1.3” or “Anamo ×2” to display the normal image without distortion on the viewfinder screen.

### Information displayed on the screen while recording

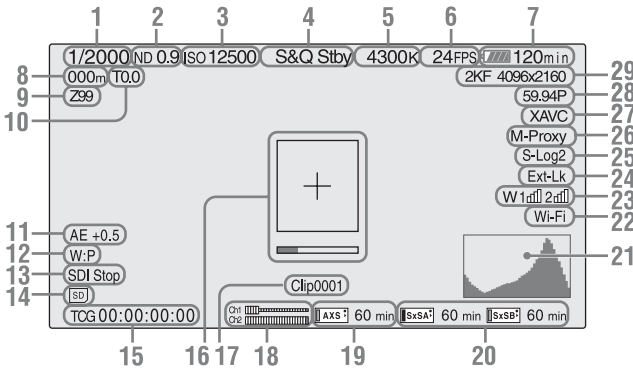

**1. Shutter mode/shutter speed indication (page 64)**

**2. ND filter indication (page 11)**

**3. Gain indication (page 61)**

Displayed as the EI value when “Shooting Mode” in “Base Setting” (page 90) of the System menu is set to “Cine EI.”

**4. Special recording/operation status indication**

● Rec	Recording in progress
Stby	Standby for recording
● S&Q Rec	Slow & Quick Motion recording in progress
S&Q Stby	Standby for Slow & Quick Motion recording

● HFR Rec	Slow & Quick Motion and Hi Frame Rate mode recording in progress
HFR Stby	Standby for Slow & Quick Motion and Hi Frame Rate mode recording
● Int Rec	Recording in progress in Interval Rec mode
Int Stby	Standby for Interval Rec recording
● Int Stby	Waiting for Interval Rec picture capturing
● Cache	● lights in green: Standby for Picture Cache Rec mode ● lights in red: Recording in progress in Picture Cache Rec mode

- 5. Color temperature indications (page 59)**
- 6. S&Q motion frame rate/Interval Rec indication (pages 66, 84)**  
Displays the interval time setting or time until the next recording, during Interval Rec.
- 7. Battery remaining charge/DC IN voltage indication (page 24)**
- 8. Focus position indication**  
Displays focus position (only when a lens that is compatible with the focus setting display function is attached).
- 9. Zoom position indication**  
Displays zoom position in the range of 0 (wide position) to 99 (tele position) (only when a lens that is compatible with the zoom setting display function is attached).
- 10. Iris position indication**  
Displays iris position (only when a lens that is compatible with the iris setting display function is attached).
- 11. Auto iris level indication**  
Displayed when “Level” in “Auto Exposure” (page 65) of the Camera menu is set to a value other than “±0.”
- 12. White balance mode indication (page 59)**
- |     |             |
|-----|-------------|
| W:P | Preset mode |
| W:M | Memory mode |
- 13. Control status of SDI output indication (page 77)**
- 14. SD card indication**
- 15. Time data indication (page 43)**
- 16. Focus assist indication (page 82)**  
Displays the area that detects the focus status (“Focus Area Marker”) and level bar that indicates focus status in the area (“Focus Assist Indicator”).
- 17. Clip name indication (page 41)**
- 18. Audio level meter**
- 19. AXS memory status/remaining space indication (page 34)**  
When the left side of the icon is orange, recording is possible.  
When the green lamp on the upper right of the icon lights, playback is possible.
- 20. A/B slot media status/remaining space indication (page 31)**  
When the left side of the icon is orange, recording is possible.  
When the green lamp on the upper right of the icon lights, playback is possible.
- 21. Video signal indication (page 82)**  
Displays the waveform, vector scope, and histogram.
- 22. Wi-Fi connection status indication (page 35)**  
Appears when “Wi-Fi” (page 94) is set to “Enable.”
- 23. Wireless receiver reception level**  
When an UHF portable tuner is installed to the buildup kit CBK-55BK (optional) attached to the camcorder, “W” appears together with four segment reception level indicators for each of the channels (1 to 2) that can be used by the tuner. The indications are as follows.  
In the normal situation: The number of segments indicates the strength of the signal level.  
Muting: The number of transfective segments indicates the strength of the signal level.  
Reception level over peak: “P” is displayed instead of the indicators.\*  
Tuner battery is low: The channel number and indicator of the corresponding channel flash.\*  
\* For DWR-S02D only
- 24. Timecode external lock indication**  
When the unit is locked to the timecode of an external device, “Ext-Lk” appears.
- 25. Gamma/Monitor LUT indication (pages 68, 78)**  
Displays the gamma setting value. When “Shooting Mode” (page 90) is set to “Cine EI,” gamma for a picture that is recorded on an SxS memory card or the Monitor LUT setting appears.
- 26. Simultaneous recording status indication (page 45)**  
M-Proxy: Displayed when the function of simultaneous recording on one memory card is effective.
- 27. Recording format (codec) indication (page 28)**  
Displays the format that is recorded on an SxS memory card.
- 28. System frequency and scan method indication (page 27)**

## 29. Recording format (picture size) indication (page 28)

Displays the picture size that is recorded on an SxS memory card.

Displays the imager scan mode (2KF: 2K Full, 2KC: 2K Center) on the left side of the picture size.

Displays imager scan mode only when recording only RAW format.

### Information displayed on the playback screen

The following information is superimposed on the playback picture.

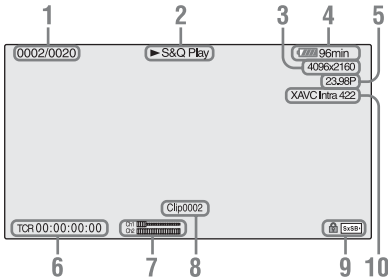

#### 1. Clip no./total number of clips

#### 2. Playback mode

#### 3. Playback format (picture size)

#### 4. Battery charge remaining/DC IN voltage

#### 5. Playback format (frame rate)

#### 6. Time data

You can switch between timecode and duration by using “TC Display” (page 83) in the TC/UB menu.

#### 7. Audio levels

The audio levels for the recording are displayed.

#### 8. Clip name

#### 9. Media

A  mark appears to the left if the memory card is write-protected.

#### 10. Playback format (codec)

## Power Supply

You can use a battery pack or AC power via an AC adaptor.

For safety, use only the Sony battery packs and AC adaptors listed below:

### Lithium-ion Battery Pack

BP-FL75

BP-L80S

### AC Adaptor

AC-DN2B

AC-DN10

## Using a Battery Pack

### Attaching a battery pack

#### 1 Attach the battery adaptor (supplied) to the camcorder.

Press the release button (①) of the battery adaptor to pop up the ejection lever, then raise the ejection lever (②).

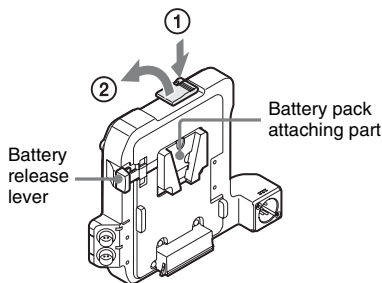

Insert the projection of the battery adaptor into the slot on the rear of the camcorder (①), then lower the ejection lever (②).

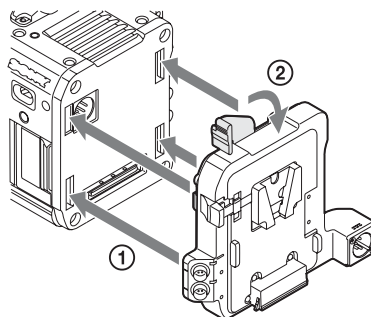

#### Notes

- Before attaching the battery adaptor, make sure that the ejection lever is raised.
- Before lowering the ejection lever, make sure that the four hooks are attached securely. If the four hooks are not attached securely, it may cause the connection to be poor or damage the camcorder and battery adaptor.

#### 2 Attach a battery pack to the battery adaptor.

Insert the battery pack into the battery pack attaching part of the battery adaptor, then slide the battery pack down to lock it in place.

#### Notes

- Before use, charge the battery pack with the battery charger.
- A warm battery pack immediately after use may not be able to be fully recharged.

### Removing a battery pack







Unlock the battery pack by sliding it up while pressing the battery release lever, then remove it. Press the release button and raise the ejection lever, then remove the battery adaptor by pulling it out while sliding upward.

#### Note

Remove the battery adaptor while supporting the camcorder by hand.

## Checking remaining battery charge

When recording or playback is in progress on the battery pack, an icon to show the current battery remaining time and battery voltage are displayed on the sub display screen (*page 17*) and viewfinder screen (*page 20*).

Icon	Remaining charge
	100% to 91%
	90% to 71%
	70% to 51%
	50% to 31%
	30% to 11%
	10% to 0%

The camcorder indicates the remaining usage time in minutes by calculating the available time with the battery pack if operation is continued at the current rate of power consumption.

### If the remaining battery charge becomes low

If the remaining battery charge decreases to a certain level during operation, a low-battery message, flashing of the REC lamp, and a beep sound will warn you.

If the remaining charge further decreases to a level at which operation cannot be continued, a battery-empty message appears.

Replace the battery pack with one that is fully charged.

### To change the message levels

These settings can be changed with “Battery Alarm” (*page 93*) in the System menu.

## Using AC Power (DC IN Power)

The camcorder works with AC power by using the AC adaptor AC-DN2B/AC-DN10 (optional) and DC cable CCDD-X2 (optional).

## Setting the Clock

When you turn the camcorder on for the first time after purchasing or replacing the backup battery, the Initial Setting display appears on the viewfinder screen.

Set the date and time of the built-in clock, using this display.

### Time Zone

The value shows the time difference from UTC (Coordinated Universal Time).

Change the setting if needed.

### Setting the time and date

Turn the MENU dial (*page 11*) to move the cursor, then press the MENU dial to set each menu item. When you press the MENU dial when the cursor is on “Finish,” the setting display disappears, the clock setting is completed.

After the setting display disappears, “Clock Set” (*page 94*) in the System menu can be used to set “Time Zone” and date/time.

### Notes

- If the clock setting is cleared because the backup battery fully discharged when no power was supplied (no battery pack and no DC IN connection), the Initial Setting display will be displayed when you next turn the camcorder on.
- While the Initial Setting display is shown, no other operation, except turning the power off, is permitted until you finish the setting for this display.



# Attaching Optional Devices

## Attaching a Lens

### Recommended lenses

PMW-F3K supplied lenses (35 mm/50 mm/85 mm)

SCL-PK6/F, SCL-PK6/M (set of 6 lenses, 20 mm/25 mm/35 mm/50 mm/85 mm/135 mm)

SCL-PK3/F, SCL-PK3/M (set of 3 lenses, 20 mm/25 mm/135 mm)

SCL-P11X15

SCL-Z18X140

*For details about available lenses for the camcorder, contact a Sony service representative.*

### Caution

Do not leave the lens facing the sun. Direct sunlight can enter through the lens, be focused in the camcorder, and cause fire.

### Notes

- Attach/remove a lens while the camcorder is turned off.
- A lens is a precision part. Do not place the lens directly with the mount part down. Attach the cover supplied with the lens.
- The lens interface of the camcorder is set to “Type C,” to correspond with the lens that is supplied with the PMW-F3K, SCL-P11X15, and lenses with a Cooke-type connector. When using a lens with an ARRI-type connector, set “Lens interface” (page 67) in the Camera menu to “Type A.” Set to “Off” for SCL-PK6, SCL-PK3, or other lenses. If this setting is not correct, an alert message appears when the camcorder is turned on after attaching the lens.

## Attaching a PL mount lens

- 1 Remove the mount cover from the lens mount by turning the PL mount lever counterclockwise.

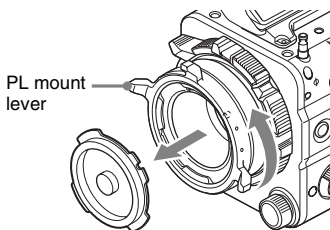

### Note

Turn the PL mount lever counterclockwise to the stopper position.

- 2 Insert the lens into the lens mount by matching the concave part of the lens to the locating pin on the upper right of the lens mount.

- 3 Fix the lens by turning the PL mount lever clockwise while holding the lens.

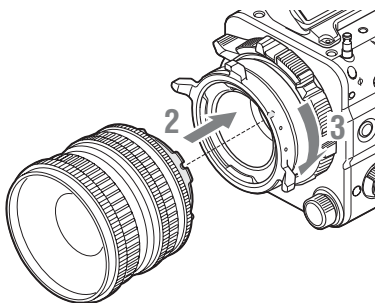

### Note

Do not turn the lens when attaching the PL mount lens. It may cause damage to the hot shoe pin.

## To attach an ARRI\* LDS lens or Cooke/i lens

Match the contact of the lens to the hot shoe of the camcorder.

Hot shoe for the Cooke/i lens

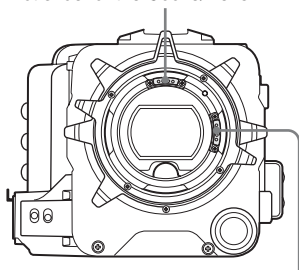

Hot shoe for the ARRI LDS lens

\* ARRI Group

## Attaching other than a PL mount lens

When using an FZ mount lens or B4 lens by attaching an optional LA-FZB1/FZB2 mount adapter, attach it after removing the mount adapter by turning the lens mount counterclockwise.

## Adjusting a flange focal length

You need to adjust the flange focal length (distance from the mounting flange to the film plane) for the following cases.

- When a lens is attached for the first time.
- When a lens is changed.
- When focus is not achieved for either tele or wide angle while using a zoom lens.

You can adjust the flange focal length by turning the screw for the flange focal length (page 11).

Use a hex key (7/64) for adjusting.

When turning the screw to the left, the flange focal length becomes long. When turning the screw to the right, the flange focal length becomes short. Turn the screw slowly.

### Notes

- The camcorder will not work if the screw for the flange focal length is turned too much. Stop turning the screw when the amount of the flange focal length no longer changes. Approximate limit for turning the screw is 7 rotations to the right/left.
- Use a hex key of the specified size. Otherwise, the screw head may be damaged and you may be unable to turn the screw.

## Removing a lens

Remove a lens with the following steps.

- 1 Turn the PL mount lever counterclockwise while holding the lens from underneath.

- 2 Pull the lens forward.

### Note

If another lens will not be attached soon, fit the concave part of the mount cover, then fix the mount cover by turning the PL mount lever clockwise.

## Selecting the lens file

By storing the adjustment value of the attached lens as a file, you can easily perform adjustment for the lens by loading the file.

Load the file in "Lens File" (page 88) of the File menu.

## Controlling zoom and focus from the external device

You can control zoom and focus from the optional CBK-DCB01 by connecting the CBK-DCB01 to the REMOTE connector (page 13) when using Sony lens SCL-Z18X140.

### Note

When connecting the CBK-DCB01 to the REMOTE connector independently, set "RM Common Memory" in "Camera Config" (page 89) of the Maintenance menu to "On."

*For details regarding CBK-DCB01 that can be used with the camcorder, contact a Sony service representative.*

## Attaching a Viewfinder

### Available viewfinders for the camcorder

- DVF-L350: LCD color viewfinder
- DVF-L700: LCD color viewfinder
- DVF-EL100: OELD color viewfinder

### Caution

Do not leave the camcorder with the eyepiece of the viewfinder facing the sun. Direct sunlight can enter through the eyepiece, be focused in the viewfinder, and cause fire.

**Notes**

- Attach/remove the viewfinder while the camcorder is turned off.
- When using the camcorder with the DVF-L700 attached, turn the camcorder on while the POWER switch of the DVF-L700 is set to ON.

For details about attaching the viewfinder, refer to the operating instructions of the viewfinder.

- 1 Loosen the fixing ring of the viewfinder shoe, align the slot of the viewfinder, then attach the viewfinder by sliding it horizontally.**

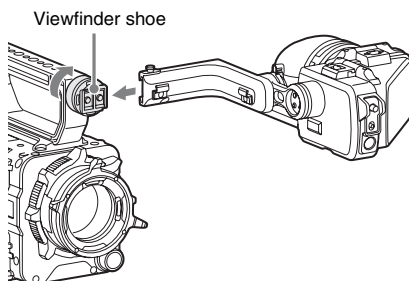

- 2 Tighten the fixing ring after determining the left and right position of the viewfinder, then connect the viewfinder cable to the VF connector of the camcorder.**

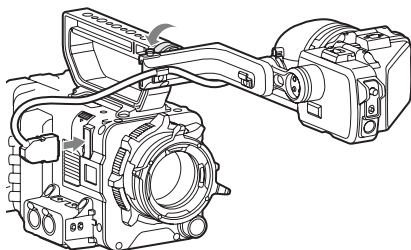
**To remove the viewfinder**

Loosen the fixing ring for the viewfinder, raise the stopper, then remove the viewfinder by sliding it in the reverse direction for when attaching.

## Setting the Basic Action

Before recording, make the basic settings, as required.

### System Frequency

Switch by setting “Frequency” in “System Setting” (page 90) of the System menu. After switching this setting, the camcorder will automatically restart, depending on the setting value.

**Note**

The system frequency setting cannot be changed during recording or playback.

### Shooting Mode

You can switch between the “Cine EI” mode (allows you to use the camcorder as a film camera, where the movie is edited post-production, rather than at the time of shooting), and the “Custom” mode (allows you to edit pictures as you make the movie, by accessing all the setting items).

Switch the mode by using “Shooting Mode” in “Base Setting” (page 90) of the System menu.

### Main Recorded Signal

Set the predominant signal format to be used. Set the format by using “Main Operation” in “Base Setting” (page 90) of the System menu. The RAW signal is recorded on the AXR-R5 attached to the camcorder, and the YPbPr or RGB signal is recorded on the SxS memory card in the camcorder. Since the RGB signal is output from the SDI 1/2 connector of the camcorder, record it on an external device such as SR-R1. Select the format from YPbPr/RGB/RAW when “Shooting Mode” is set to “Cine EI,” and from YPbPr/RGB when “Shooting Mode” is set to “Custom.”

**Note**

The RAW signal can be selected only when attaching the AXS-R5. If the AXS-R5 is not attached, “Main Operation” is locked to “YPbPr” or “RGB.”

## Color Space

Select the color gamut that is to be the basis of the recorded signal and the output signal.

When “Shooting Mode” is set to “Cine EI,” select the color gamut for video output of which MLUT is set to off. When “Shooting Mode” is set to “Custom,” “Color Space” is locked to “Matrix.” Select it by using “Color Space” in “Base Setting” (page 90) of the System menu.

S-Gamut/SLog2: Wider gamut that is comparable with a film camera.

S-Gamut3.Cine/SLog3: Color gamut that is easy to adjust for digital cinema (DCIP3).

S-Gamut3/Slog3: Wide color gamut optimized by Sony’s original image distortion correction technology, and adaptable to the color gamut that will be standardized in the future.

Matrix: Selects the color gamut by Matrix setting as done with traditional cameras (when “Shooting Mode” is set to “Custom”).

### Note

Gamma curve is locked to “S-Log2” when “S-Gamut/SLog2” is selected, gamma curve is locked to “S-Log3” when “S-Gamut3.Cine/SLog3” or “S-Gamut3/SLog3” is selected.

## Imager Scan Mode

You can set the shooting method for the image sensor.

Select the mode by using “Imager Scan Mode” in “Base Setting” (page 90) of the System menu.

Normal: Uses the full angle of Super 35 mm size as it is, except at the high frame rate mode of the Slow & Quick Motion function.

When “High Frame Rate Mode” in “S&Q Motion” (page 66) of the Camera menu is set to “Full Scan,” the full angle picture of Super 35 mm size that is converted to 2K data is used. When “High Frame Rate Mode” in “S&Q Motion” (page 66) of the Camera menu is set to “Center Scan,” the 2K angle picture that is half of the Super 35 mm size (center area of the picture) is used.

2K Full: Uses the full angle picture of Super 35 mm size that is converted to 2K data.

2K Center: Uses the 2K angle picture that is half of the Super 35 mm size (center area of the picture).

## Recording Format

Selectable formats vary, depending on the system frequency and main recorded signal settings.

System frequency	Main recorded signal	Format
59.94/50	YPbPr	XAVC 4096 × 2160P*
		XAVC 3840 × 2160P*
		XAVC 2048 × 1080P
		XAVC 1920 × 1080P
		MPEG 1920 × 1080i
		MPEG 1280 × 720P
		SSiP SR-SQ 422 (59.94 only)
		DNxHD 220x HD i**
		DNxHD 145 HD i**
		ProRes 422 HQ HD i**
		ProRes 422 HD i**
29.97/25/ 23.98	YPbPr	RGB
		XAVC 2048 × 1080P***
		XAVC 1920 × 1080P***
		MPEG 1920 × 1080i***
		RAW
		XAVC 2048 × 1080P***
24	YPbPr	XAVC 1920 × 1080P***
		MPEG 1920 × 1080i***
		SSiP SR-SQ 422
		SSiP SR-Lite 422
		DNxHD 220x HD P**
		DNxHD 145 HD P**
		ProRes 422 HQ HD P**
		ProRes 422 HD P**
		RGB
		XAVC 2048 × 1080P***
24	YPbPr	XAVC 1920 × 1080P***
		MPEG 1920 × 1080i***
		RAW
		XAVC 2048 × 1080P***
24	YPbPr	XAVC 4096 × 2160P*
		XAVC 2048 × 1080P
		SSiP SR-SQ 422
		SSiP SR-Lite 422
		ProRes 422 HQ HD P**
		ProRes 422 HD P**
		RGB
		XAVC 2048 × 1080P***
		SSiP SR-SQ 444
		RAW
XAVC 2048 × 1080P***		

\* PMW-F5 with the CBKZ-55FX applied or PMW-F55 only.

\*\* When the CBK-55PD is installed.

\*\*\* The recorded signal is YPbPr.

To change the format, use “Format” in “Rec Format” (*page 91*) of the System menu. Signals from the SDI OUT and HDMI OUT connectors are also output according to the format selected with this menu.

## Using SxS Memory Cards

This camcorder records audio and video on SxS memory cards (optional) inserted in the card slots.

### About SxS Memory Cards

Use the following Sony SxS memory cards or XQD memory cards\*.

\* When using an XQD memory card, the XQD ExpressCard adapter (QDA-EX1) is required.

Available memory cards differ depending on the recording format and “On”/“Off” setting of “High Frame Rate Mode.”

#### SxS PRO+

SBP-128B, SBP-64B: Available for all recording formats, and when “High Frame Rate Mode” is set to “On” or “Off.”

#### SxS PRO

SBP-64A, SBP-32: SStP SR-Lite 422, XAVC 2048 × 1080P/1920 × 1080P (only when “High Frame Rate Mode” is set to “Off”), MPEG 1920 × 1080P/i, 1280 × 720P, DNxHD 220x HD P/i, DNxHD 145 HD P/i, ProRes 422 HD P/i, ProRes 422 HQ HD P/i

#### SxS-1

SBS-64G1A, SBS-32G1A: MPEG 1920 × 1080P/i, 1280 × 720P

#### XQD memory card S series, G series

QD-S64E, QD-S32E, QD-G128A, QD-G64A, QD-G32A: Available for all recording formats, and when “High Frame Rate Mode” is set to “On” or “Off.”

#### XQD memory card N series

QD-N64: MPEG 1920 × 1080P/i, 1280 × 720P

Operations are not guaranteed with other memory cards.

These memory cards comply with the ExpressCard standard.

*For details on using SxS memory cards and usage-related precautions, refer to the instruction manual for the SxS memory card.*

- SxS, SxS PRO, and SxS-I are trademarks of Sony Corporation.
- XQD is a trademark of Sony Corporation.
- The ExpressCard word mark and logo are owned by Personal Computer Memory Card International Association (PCMCIA) and are licensed to Sony Corporation. All other trademarks are the property of their respective owners.

## Inserting an SxS Memory Card

- 1 **Open the cover of the card slot block** (*page 14*).
- 2 **Insert the SxS memory card into the slot with the SxS label facing to the right.**  
The ACCESS lamp (*page 14*) lights in red then changes to green once the memory card is ready for use.
- 3 **Close the cover.**

### Status indications by the ACCESS lamps

Card slots A and B are accompanied by the respective ACCESS lamps to indicate their status.

Lamp	Slot statuses
Lights in red	Accessing the SxS memory card (writing/reading data)
Lights in green	Standby (ready for recording or playback using the SxS memory card)
Off	<ul style="list-style-type: none"> <li>• No SxS memory card is loaded.</li> <li>• The loaded card is invalid.</li> <li>• An SxS memory card is loaded, but another slot is active.</li> </ul>

## Removing an SxS memory card

- 1 **Open the cover of the card slot block, press the EJECT button** (*page 14*), **then pull the button out.**
- 2 **Press the EJECT button again to remove the card.**

### Note

Data integrity is not guaranteed if the power is turned off or a memory card is removed while it is being accessed. Data on the card may be destroyed. Be sure that its ACCESS lamp is lit in green or off when you turn off the power or remove a memory card.

## Switching Between SxS Memory Cards

When SxS memory cards are loaded in both card slots A and B, press the SLOT SELECT button (*page 14*) to select the card you wish to use. If a card becomes full, recording continues after automatically switching to the second card.

### Note

The SLOT SELECT button is disabled while recording/playback is in progress. Switching is not executed even if you press the button. The button is enabled while the thumbnail screen is displayed (*page 47*).

## Formatting an SxS Memory Card

If an SxS memory card is not formatted, or was formatted with another system, the message “Media Needs to be Formatted” is displayed on the viewfinder screen.

Format the card as instructed follows.

**Using “Format Media”** (*page 85*) **in the Media menu, specify “Media(A)” (slot A) or “Media(B)” (slot B) then select “Execute.”** **On a confirmation message, select “Execute” again.**

The in-progress message and status bar are displayed, and the ACCESS lamp lights in red. When formatting is complete, a completion message is displayed. Press the MENU dial to hide the message.

### Recording/playback during formatting

You can perform recording or playback using the SxS memory card in the other card slot while formatting is in progress.

### If formatting fails

A write-protected SxS memory card or memory card that cannot be used with this camcorder will not be formatted.

As a warning message is displayed, replace the card with an appropriate SxS memory card, according to the instructions in the message.

### Note

All the data, including recorded pictures and setup files, are erased when a memory card is formatted.

## Checking the Remaining Time Available for Recording

While recording (or standing by to record), you can check the remaining space for the SxS memory cards loaded in the card slots on the A/B slot media status/remaining space indication of the sub display (*page 17*) or viewfinder screen (*page 20*).

The available time for recording with the current video format (recording bit rate) is calculated according to the remaining space of each card and displayed in time units of minutes.

### Note

A  icon appears if the memory card is write-protected.

## Replacing an SxS memory card

- If the available time on two cards in total becomes less than 5 minutes, the message “Media Near Full,” flashing the REC lamp, and a beep sound, will warn you. Replace the cards with those that have sufficient space.
- If you continue recording until the total remaining time reaches zero, the message changes to “Media Full,” and recording stops.

### Note

Up to approximately 600 clips can be recorded on one SxS memory card.

If the number of recorded clips reaches the limit, the remaining time indication becomes “0,” and the message “Media Full” is displayed.

## Restoring an SxS Memory Card

If a data error occurs in a memory card for some reason, the card must be restored.

If an SxS memory card that needs to be restored is loaded, a message prompting you to execute the restore operation is displayed on the viewfinder screen.

Restore the card as instructed follows.

### Select “Execute” by turning the MENU dial, then press the MENU dial.

During restoration, the in-progress message and status bar are displayed, and the ACCESS lamp lights in red.

When restoration is completed, the completion message is displayed, then press the MENU dial to disappear the message.

### If restoration fails

- A write-protected SxS memory card, or one on which an error occurred, cannot be restored. For such a card, a warning message is displayed. Release the write protection or replace the card, according to the instructions in the message.
- An SxS memory card on which an error occurred may become usable again through repeated formatting.
- In some cases, only parts of clips cannot be restored. Playback of the restored clips becomes possible again.
- The following operation may restore an SxS memory card for which the message “Could not Restore Some Clips” is repeatedly displayed each time you try the restoration process:

- 1 Copy necessary clips to another SxS memory card, using the dedicated application software (*page 124*).
- 2 Format the problem SxS memory card, using the format function of this camcorder.
- 3 Copy the clips back to the SxS memory card.

### Recording/playback during restoration

You can perform recording or playback using the SxS memory card in the other card slot while restoration is in progress.

### Note

For restoration of media recorded with this unit, be sure to use this unit. Media recorded with a device other than this unit or with another unit of different version (even of the same model) may not be restored using this unit.

## To update the managerial file

If clips cannot be played back, updating the managerial file on the card may improve the situation. For this operation, use “Update Media” (*page 85*) of the Media menu.

If you write an XAVC file that is imported by RAW Viewer V2.2 or later to the “XDROOTClip” directory of an SxS memory card directly, that file can be played by performing “Update Media.”

## Using an SD Card

You can store the setting value file of the camera on an SD card (optional). The stored file can be loaded from the SD card.

### Usable SD Cards

**SDHC memory card\*** (Speed Class: 4 to 10, UHS is not compatible, Capacity: 2 GB to 32 GB)  
**SD memory card\*** (File system: FAT 16, Capacity: up to 2 GB)

\* Indicated as "SD card" in these Operating Instructions.

### Inserting an SD Card

- 1 **Open the cover of the card slot block (page 14).**
- 2 **Insert the SD memory card into the slot with the SD label facing up.**  
 The ACCESS lamp (page 14) lights in red then changes to green once the memory card is ready for use.
- 3 **Close the cover.**

#### Status indications by the ACCESS lamp

Lamp	Slot statuses
Lights in red	Accessing the SD card (writing/reading data)
Off	<ul style="list-style-type: none"> <li>• No SD card is loaded.</li> <li>• The loaded card is invalid.</li> </ul>

### Removing an SD memory card

**Open the cover of the card slot block, remove the SD card by pressing the SD card once lightly.**

#### Notes

- Data integrity is not guaranteed if the power is turned off or a memory card is removed while it is being accessed. Data on the card may be destroyed. Be sure that its ACCESS lamp is lit in green or off when you turn off the power or remove a memory card.
- Make sure that the card does not pop out when inserting or removing it.

### Formatting an SD Memory Card

When you use an SD memory card with this camcorder, it must be formatted using the format function of this camcorder.

It is also necessary to format an SD memory card if a caution message is displayed when you mount it.

For an SD memory card that was formatted with another system unsupported by this camcorder, the message "File System Mismatch" is displayed on the viewfinder screen.

Format the card as instructed follows.

**Using "Format Media" (page 85) in the Media menu, specify "SD card" then select "Execute." On a confirmation message, select "Execute" again.**

The in-progress message and status bar are displayed, and the ACCESS lamp lights in red. When formatting is complete, a completion message is displayed. Press the MENU dial to hide the message.

#### Note

All the data are erased when a memory card is formatted, and the data cannot be restored.

### Checking the Remaining Time

The remaining time can be checked on the Media status screen (page 13).

#### Note

A  icon appears if the memory card is write-protected.

**To use media formatted with this camcorder in the slots of other devices**

Make a backup of the media, then format it using the other device.



## Using an AXS-R5

You can record image/audio (RAW format) data to the AXS (Access Memory Card System) recorder AXS-R5 (optional) by connecting the AXS recorder to the camcorder.

### Attaching the AXS-R5

#### Note

Attach/remove the AXS-R5 while the camcorder is turned off.

- 1 Press the release button of the AXS-R5 (①) to pop up the ejection lever, then raise the ejection lever (②).

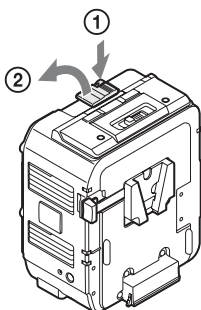

- 2 Insert the projection of the AXS-R5 into the slot on the rear of the camcorder (①), then lower the ejection lever (②).

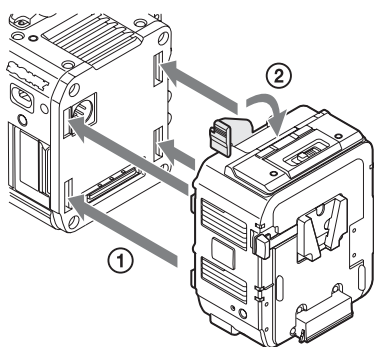

#### Notes

- Before attaching the AXS-R5, make sure that the ejection lever is raised.

- Before lowering the ejection lever, make sure that the four hooks are attached securely. If the four hooks are not attached securely, it may cause the connection to be poor or damage the camcorder and AXS-R5.

### Removing the AXS-R5

Press the release button and raise the ejection lever, then remove the AXS-R5 by pulling it out while sliding upward.

#### Note

Remove the AXS-R5 while supporting the camcorder by hand.

### Inserting an AXS Memory Card

- 1 Open the cover by sliding the memory slot cover open/close button on the top of the AXS-R5.

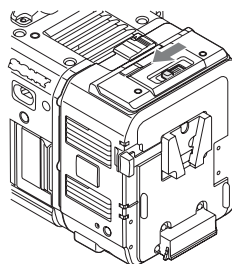

- 2 Insert the AXS memory card into the card slot with the label facing as indicated below.

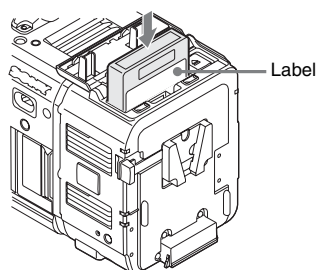

- 3 Close the cover.

## Removing an AXS Memory Card

Open the cover of the AXS-R5, press the **EJECT** button and remove the AXS memory card.

### Note

Data integrity is not guaranteed if the power is turned off or a memory card is removed while it is being accessed. Data on the card may be destroyed. Be sure that its ACCESS lamp is lit in green or off when you turn off the power or remove a memory card.

## Recording to an AXS Memory Card

Set “Shooting Mode” in “Base Setting” (page 90) to “Cine EL,” and “Main Operation” in “Base Setting” (page 90) to “RAW” of the System menu.

For settings of the AXS-R5, see “AXS Recorder” (page 94) of the System menu.

## Formatting an AXS Memory Card

When you use an AXS memory card with the AXS-R5 that is attached to the camcorder, it must be formatted using the format function of this camcorder.

It is also necessary to format an AXS memory card if a caution message is displayed when the camcorder is turned on with the AXS recorder attached.

For an AXS memory card that was formatted with another system unsupported by the AXS-R5, the message “Media Needs to be Formatted” is displayed on the viewfinder screen.

Format the AXS memory card as follows.

**Using “Format Media” (page 85) in the Media menu, specify “AXS Memory” (slot B), then select “Execute.”**

An in-progress message and status bar are displayed, and the ACCESS lamp lights in red. When formatting is complete, a completion message is displayed. Press the MENU dial to hide the message.

### Note

When formatting, all data in an AXS memory card are erased and cannot be restored.

## Checking the Remaining Time Available for Recording

While recording (or standing by to record), you can check the time remaining for the AXS memory cards on the AXS memory status/remaining space indication of the sub display (page 17) or viewfinder screen (page 20). The available time for recording with the current video format (recording bit rate) is calculated according to the remaining space of each card and displayed in time units of minutes.

### Note

A  icon appears if the memory card is write-protected.

## Restoring the AXS Memory Card

If a data error occurs on the AXS memory card for some reason, the card must be restored.

If an AXS memory card that needs to be restored is connected, a message prompting you to execute restoration is displayed on the viewfinder screen. Restore the card as instructed follows.

**Select “Execute” by turning the MENU dial, then press the MENU dial.**

During restoration, the in-progress message and status bar are displayed, and the ACCESS lamp lights in red.

When restoration is completed, the completion message is displayed, then press the MENU dial to disappear the message.

### If restoration fails

- A write-protected AXS memory card or one on which an error occurred cannot be restored. For such a card, a warning message is displayed. Release the write protection or replace the card, according to the instructions in the message.
- An AXS memory card on which an error occurred may become usable again through repeated formatting.
- In some cases, only parts of clips cannot be restored. Playback of the restored clips becomes possible again.

### Note

For restoration of media recorded with this unit, be sure to use this unit. Media recorded with a device other than this unit or with another unit of different version (even of the same model) may not be restored using this unit.

---

## To update the managerial file

---

If clips cannot be played back, updating the managerial file on the card may improve the situation. For this operation, use “Update Media” (page 85) of the Media menu.

## Using a USB Wireless LAN Module

You can make the Wi-Fi connection between the camcorder and a device such as a smartphone, tablet, etc., by attaching the supplied IFU-WLM3 USB wireless LAN module.

### Note

- The IFU-WLM3 USB Wireless LAN Module (supplied) may not be available in some countries/regions.
- Attach/remove the IFU-WLM3 after the camcorder is turned off.
- If you use a wireless device near the camcorder, the camcorder may not work correctly. Turn the wireless device off near the camcorder.
- You cannot use a USB wireless LAN module other than the IFU-WLM3.

Making a Wi-Fi connection between a device and the camcorder enables you to do the following.

- Operate the setup menu
- Record and playback the camcorder
- Display the current status of the camcorder
- Switch between the recording settings and system settings
- Operate the assignable buttons of the camcorder

## Attaching the IFU-WLM3

- 1** Open the cover of the USB wireless LAN module retracting part (page 13).
- 2** Insert the IFU-WLM3 to the USB connector.
- 3** Close the cover.

## Making a Wi-Fi Connection

### Note

Only one Wi-Fi device can be connected at a time.

### To make a network setting

Change the “Basic Authentication” settings (page 94) of the System menu as required.

Item	Setting
User Name	User name for log-in (factory default setting: “admin”)
Password	Password for log-in (factory default setting: model name “pmw-f5” or “pmw-f55”)

For details about the menu settings and entering a character string, see “Setup Menu Operations” (page 56).

### To make a connection

**1** Set “Wi-Fi” in “Wi-Fi” (page 94) of the System menu to “Enable.”

**2** Make a Wi-Fi connection by inputting the SSID and Password onto the device, or by using the Wi-Fi direct connection function.

You can check the SSID and password of the camcorder on “SSID & Password” in “Wi-Fi” (page 94) of the System menu.

When using the Wi-Fi direct connection function, proceed to the following step.

**3** Select “Execute” for “Wi-Fi Direct Connection” in “Wi-Fi” of the System menu.

The setup menu disappears, and the connection wait message for the Wi-Fi direct connection function appears.

#### Using the Push-Button method

When you perform the Push-Button method on the device, the message for connection permission appears on the connection wait screen. Select “Execute.”

#### Using the PIN code method

When you perform the PIN code method on the device, the device name and PIN code appears on the connection wait screen.

Complete the connecting process by inputting the PIN code to the device.

## Using the Wi-Fi Remote Commander

When a Wi-Fi connection is established between a device such as smartphone, tablet, etc., and the camcorder, the Wi-Fi remote commander appears on the device screen and the device can be used as a remote commander.

You can start/stop recording and adjust the recording settings with a Wi-Fi connected device. This function is useful for setting the camcorder in a remote place, such as the top of a crane, etc.

### Note

The Wi-Fi remote commander is not capable of the following functions.

- Zoom, Focus, and Iris control.
- Displaying the thumbnail screen.

### Wi-Fi remote commander displays

#### Smartphone

##### Main screen



- Wi-Fi connecting status (Connected/Disconnected)
- Status indication: operating status, time data, audio level meter, clip name, recording format, media status/remaining space, battery remaining charge/DC IN voltage
- Recording settings indication: S&Q FPS, Shutter, Color Temp., Sensitivity/Gain/Exposure Index, Gamma, MLUT, Color Bars, Auto Black, Auto White

## Playback screen



- Wi-Fi connecting status (Connected/Disconnected)
- Status indication
- Playback operation button:  
F Rev, Play/Pause, F Fwd, Prev, Stop, Next

## Cursor screen



- Wi-Fi connecting status (Connected/Disconnected)
- Status indication
- Cursor operation button, menu/status indication:  
Up, Left, Set, Right, Down, Cancel/Back, Menu, Status

## Assign screen



- Wi-Fi connecting status (Connected/Disconnected)
- Status indication
- Assignable button indication:  
Assignable buttons 1 to 4

## Tablet

### Main screen



- Wi-Fi connecting status (Connected/Disconnected)
- Status indication:  
operating status, time data, audio level meter, clip name, recording format, media status/remaining space, battery remaining charge/DC IN voltage
- Assignable button indication:  
Assignable buttons 1 to 4
- Recording settings indication:  
S&Q FPS, Shutter, Color Temp., Sensitivity/Gain/Exposure Index, Gamma, MLUT, Color Bars, Auto Black, Auto White

### Playback screen



- Wi-Fi connecting status (Connected/Disconnected)
- Status indication
- Assignable button indication
- Playback operation button:  
F Rev, Play/Pause, F Fwd, Prev, Stop, Next

### Cursor screen



- Wi-Fi connecting status (Connected/Disconnected)
- Status indication
- Assignable button indication
- Cursor operation button, menu/status indication:  
Up, Left, Set, Right, Down, Cancel/Back, Menu, Status

## To display the Wi-Fi remote commander

The display size of the Wi-Fi remote commander changes according to the device screen size automatically.

- 1 Make a Wi-Fi connection between the device and camcorder (page 36).**
- 2 Launch the browser and input `http://<camcorder's IP address>` (“System menu” > “Wi-Fi” > “IP Address”)/`rm.html` in the address bar.**  
Example: When the IP address is 10.0.0.1, input `http://10.0.0.1/` in the address bar.
- 3 Input the user name and password (“System menu” > “Basic Authentication” > “User Name” or “Password”) on the browser.**

When completing the connection, the display of the Wi-Fi remote commander appears on the device.

Operate the Wi-Fi remote commander by following the display.

The REC button becomes unavailable when the Lock switch is dragged to the right.

### Notes

- Depending on the device, the Wi-Fi remote commander may not appear properly on the device's screen even though you input `http://<camcorder's IP address>/rm.html` in the address bar. In this case, input `“rms.html”` for a smartphone or `“rmt.html”` for a tablet instead of `“rm.html”` at the end of the address to display the Wi-Fi remote commander properly.
- The Wi-Fi remote commander on the device's screen may no longer match the actual status of the camcorder in the following cases. When this happens, refresh the browser on the device.
  - when the camcorder is restarted while the Wi-Fi connection is established
  - when the camcorder is controlled directly while the Wi-Fi connection is established
  - when the device is reconnected
  - when you operate forward/backward on the device's browser.
- If the Wi-Fi signal is poor, the Wi-Fi remote commander may not work properly.

## Compatible devices

The following devices, using the specified versions or higher, can be used as Wi-Fi remote commanders.

Device	OS	Browser
Smartphone	Android 4.3/4.4	Chrome V31
	iOS 7	Safari 6
Tablet	Android 4.3/4.4	Chrome V31
	iOS 7	Safari 6

## Operate the setup menu from the Wi-Fi remote commander (Tablet only)

To display the setup menu on the tablet, select “Setup Menu” on the global menu that is displayed by touching the Menu icon (☰) on the upper left of the Wi-Fi remote display of the tablet.

To return to the camera control screen, select “Camera Control” on the global menu.

Menu icon

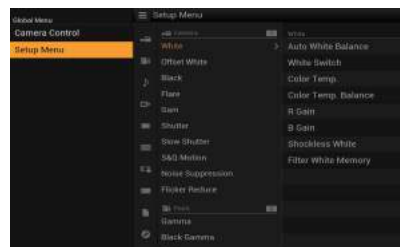

You can set/display the following items of the setup menu on the Wi-Fi remote display (tablet) (○: compatible, -: not compatible).

<b>Camera menu</b>	
White	○
Offset White	○
Black	○
Flare	○
Gain	○
Shutter	○
Slow Shutter	○
Auto Exposure	-
S&Q Motion	○
Color Bars	-
Noise Suppression	○
Flicker Reduce	○
Image Inversion	-
Lens Interface	-
<b>Paint menu</b>	
Gamma	○
Black Gamma	○
Knee	○
White Clip	○
Detail	○
Aperture	○
Skin Detail	○
Matrix	○
Multi Matrix	○
<b>Audio menu</b>	
Audio Input	-
Audio Level	-
Audio Output	○
<b>Video menu</b>	
Output On/Off	○
Output Format	○
Output Setting	○
Monitor LUT	○
Output Display	○
<b>VF menu</b>	
VF Setting	-
Peaking	-
Marker	○
Zebra	-
Display On/Off	-
<b>TC menu</b>	
Timecode	○
TC Display	○

<b>Recording menu</b>	
Interval Rec	○
Picture Cache Rec	○
MPEG2 Proxy	○
Rec Control	○
SDI Rec Control	○
<b>Media menu</b>	
Update Media	-
Format Media	○
Clip Naming	○
<b>File menu</b>	
All File	○
Scene File	○
User Menu Item	-
User Gamma	○
Monitor LUT	○
Monitor 3D LUT	○
Lens File	○
<b>Maintenance menu</b>	
APR	-
Test Saw	-
Camera Config	-
<b>System menu</b>	
System Setting	○
Base Setting	○
Rec Format	○
Genlock	-
Assignable Button	-
Switch / Lamp	-
Fan Control	○
Battery Alarm	-
DC Voltage Alarm	-
Language	-
Clock Set	-
Hours Meter	-
AXS Recorder	-
Basic Authentication	-
Wi-Fi	-
All Reset	-
Version	○

#### Notes

- When the setup menu is displayed on the Wi-Fi remote commander, you cannot set the setup menu items other than “Basic Authentication” and “Wi-Fi” of the System menu on the camcorder.
- When the setup menu is displayed on the Wi-Fi remote commander, you cannot change the settings on the sub display.

## Basic Operation Procedure

Basic recording can be performed with the following procedures.

- 1 Make sure that the necessary devices are attached to the camcorder and power is supplied to them.**
- 2 Load the memory card(s).**  
If you load two cards, recording is continued by automatically switching to the second card when the first card becomes full.
- 3 Set the power switch (*page 12*) to the ON position.**  
The recording screen is displayed on the viewfinder screen.
- 4 Press the REC button (*page 11*).**  
The REC lamp lights and recording begins.

### Note

If the camcorder cannot start recording immediately after the pressing the REC button, the REC lamp flashes. The REC lamp lights when recording starts.

- 5 To stop recording, press the REC button again.**  
Recording stops and the camcorder enters STBY (recording standby) mode.

---

### Playing a recorded clip

---

You can play the recorded clip while the camcorder is in standby mode.

- 1 Insert the SxS memory card.**
- 2 Press the VIEW button in the function button (*page 14*) once to display the VIEW-1 screen.**
- 3 Search the desired clip by pressing Prev or F Rev button on the sub display.**
- 4 Press the Play/Pause button on the sub display.**  
The playback image appears on the viewfinder.

Playback operation is performed by the buttons on the sub display.

Play/Pause button: Pauses playback. To resume playback, press this button again.

F Fwd button/F Rev button: Plays fast. To return to normal playback, press the Play/Pause button.

Stop button: Stops playback or recording.

---

### Monitoring audio

---

In normal playback mode, you can monitor the recorded audio signals through the built-in speaker (*page 11*) or connected headphones. When connecting the headphones to the headphones connector (*page 14*), the built-in speaker is turned off.

You can select audio channel to be monitored and adjust the sound volume with “Audio Output” (*page 75*) in the Audio menu.

---

### Cueing Up

---

#### To start playback from the top of the clip

Press the Prev button or Next button on the sub display (*page 17*). You can cue to the top of the desired clip by pressing the button repeatedly.

---

### Switching the SxS memory cards

---

When two memory cards are loaded, press the SLOT SELECT button (*page 14*) to switch memory cards.

### Note

You cannot switch SxS memory cards during playback. Continuous playback of cards in slots A and B is not possible.

---

### Switching to the AXS memory card

---

You can play the picture that is recorded on the AXS memory card in the AXS-R5 by developing simply. To switch to the AXS memory card, press the SELECT button of the AXS-R5. The playback signal is output from the output connector of the camcorder.



## Note

When connecting the camcorder and AXS-R5, only EE\* is output from the AUX OUT connector of the AXS-R5. Playback picture is not output. Playback picture is output from the camcorder.

\* EE is not output while in the Slow & Quick Motion mode.

### Clip (recording data)

When you stop recording, video, audio and subsidiary data from the start to end of the recording are recorded as a single clip on an SxS memory card.

### Clip name

For each clip recorded with this camcorder, a clip is named by the naming mode that is set in “Clip Naming” (page 85) of the Media menu. The Shot Number and clip number are automatically incremented.

When storing the clip name by the “Cam ID + Reel#” naming mode (page 85), the clip name is created as follows:

- When there is already a clip name that is stored by the “Cam ID + Reel#” naming mode on the inserted AXS memory card, the new file inherits its information.

#### Examples:

When “B002C003\_XXXXXXXX” is on the AXS memory card, the next created clip name is “B002C004\_XXXXXXXX.” The Camera ID of “AXS Recorder” in the System menu is changed to “B,” and Reel Number is changed to “002.” The clip name on the information that is displayed during shooting flashes until the camera starts recording.

- When the inserted AXS memory card has no file, “1” is added to the Reel Number of the clip that was recorded last.

#### Examples:

When you record on empty card “2” after recording up to “D001CXXX\_XXXXXXXX” on card “1,” the next created clip name is “D002C001\_XXXXXXXX.” The clip name on the information that is displayed during shooting flashes until the camera starts recording.

- When you set the Camera ID and Reel Number of “Clip Naming” in the Media menu, that information is applied.

#### Examples:

When you change the Camera ID to “F” and Reel Number to “001” of the AXS memory card that is recorded up to “E003CXXX\_XXXXXXXX,” the next clip name is “F001CXXX\_XXXXXXXX.” When you change the Camera ID only, the Reel Number is changed to “001.”

When storing the clip name by the “Title” naming mode (page 85), the clip name is created from characters that are set in “Title Prefix” (1 to 46 characters) + clip number that is set in “Number Set” (0001 to 9999).

### Maximum duration of a clip

The maximum clip length is 6 hours.

If you exceed the maximum clip length, a new clip will be automatically created. You can check the new clip on the thumbnail screen.

## Changing Basic Settings

You can make changes to the settings based on the intended usage of the recorded video or recording conditions.

### Electronic Shutter

Set the shutter speed (cache time).

When you set “Setting” in “Shutter” (*page 64*) of the Camera menu to “On,” the shutter speed that you specified with “Shutter” is turned on.

#### Note

When the viewfinder double speed drive function (*page 46*) is activated, the electronic shutter function is locked to on, and the shutter angle is limited up to 180 degrees.

### Setting the shutter mode and speed

Select “Mode” and “Select” in “Shutter” (*page 64*) of the Camera menu, then set the speed in “Shutter Value.”

### Shooting in slow shutter

The shutter speed is specified in the number of accumulated frames. This function allows you to obtain low-noise clear pictures in low light levels or surreal pictures with afterimages.

Set “Setting” in “Slow Shutter” (*page 65*) of the Camera menu to “On,” and specify the number of accumulated frames with “Number of Frames.”

### Sensitivity/Gain/Color Temperature/White Balance

The setting items differ, depending on the shooting mode setting.

These items can be set on the setup menu and sub display.

#### While in “Cine EI” mode: Selecting the sensitivity (EI value) and color temperature

Set the sensitivity by using “Exposure Index” in “Gain” (*page 61*) of the Camera menu.

For the Cine EI mode, it is assumed that the RAW signal or output picture, for which MLUT is set to

off, is recorded as the main recorded signal.

Sensitivity for the main recorded signal is locked to standard sensitivity, and the picture brightness is changed in accordance with the EI value only for the output picture, for which MLUT is set to on.

You can check the processing result of sensitizing or desensitizing on post-production while shooting by using the picture, for which MLUT is set on.

You can set the following values for the sensitivity (EI value)

PMW-F5: 500EI, 640EI, 800EI, 1000EI, 1250EI, 1600EI, 2000EI, 2500EI, 3200EI, 4000EI, 5000EI, 6400EI, 8000EI

PMW-F55: 320EI, 400EI, 500EI, 640EI, 800EI, 1000EI, 1250EI, 1600EI, 2000EI, 2500EI, 3200EI, 4000EI, 5000EI

Select the color temperature from among “Preset 3200K” (tungsten), “4300K” (tungsten), and “5500K” (daylight), in “White” (*page 59*) of the Camera menu.

#### While in “Custom” mode: Selecting the sensitivity or gain, and color temperature or white balance

Select the sensitivity (ISO) or gain (dB) in “Gain” (*page 61*) of the Camera menu.

Select the color temperature or white balance in “White” of the Camera menu.

The color temperature can be selected for Memory A/Memory B from among “Preset 3200K” (tungsten), “4300K” (tungsten), and “5500K” (daylight), and you can select any color temperature by using “Color Temp.” in “White” (*page 59*) of the Camera menu.

For white balance, adjust automatically by using “Auto White Balance,” or adjust Memory A/Memory B by using “Color Temp. Balance,” “R Gain,” or “B Gain,” in “White” of the Camera menu.

## Audio

### To adjust the audio levels

When “CH-1 Audio Select/CH-2 Audio Select” in “Audio Level” (*page 75*) of the Audio menu is set to “Auto,” the audio recording levels are automatically adjusted.

To adjust the audio recording levels manually, set to “Manual.” Adjust the audio recording levels on “CH-1 Audio Level/CH-2 Audio Level” in “Audio Level” of the Audio menu.

#### Note

The recording level is locked for channels with AES/EBU signals selected for audio input.

## Time Data

### Setting the Timecode

Specify the timecode to be recorded with “Timecode” in the TC/UB menu (*page 83*).

## Useful Functions

### Assignable Buttons

The camcorder has four assignable buttons (*pages 11, 13*) to which you can assign various functions for convenience.

You can also assign the function to the RET button on the lens.

### Changing functions

Use “Assignable Button” (*page 92*) in the System menu.

The assigned functions can be viewed on the Assignable button status screen (*page 12*).

### Assigned functions

Function name	Function
Marker	Turning on/off the Center Marker, Safety Zone, Aspect Marker.
Zebra	Turning on/off the Zebra function.
Peaking	Turning on/off the Peaking function.
Display	Turning on/off the monitor display of status/setting value.
Video Signal Monitor	Switching the waveform indication for the output signal from SDI (Sub).
VF Focus Magnifier	Turning on/off the Focus Magnifier function of the viewfinder.
VF Mode	Switching viewfinder screen between color and mono.
Rec	Starting/stopping recording.
S&Q Motion	Turning on/off the Slow & Quick Motion.
Picture Cache Rec	Turning on/off the Picture Cache Rec function.
Rec Review	Performing the Rec Review function.
High/Low Key	Switching between High Key (monitoring display for high key blown-out highlights), Low key (monitoring display for low key clipped blacks), and Off (normal display).
White Memory	Switching “White Switch” between Memory A and Memory B.

Function name	Function
VF High Contrast	Enhancing the contrast of the pictures on the viewfinder.
Color Bars	Turning the color bar on/off.

## Slow & Quick Motion

When “Main Operation” is set to “RAW” or “YPbPr,” and the system frequency and video format (page 90) are set as follows, you can set the recording frame rate and playback frame rate to different values.

Main Operation	Recording format	System frequency	Frame rate*
RAW	– (When recording on an AXS only)	23.98P/24P/	1 to
		25P/29.97P/50P/59.94P	240P**
YPbPr	XAVC 4096 × 2160P	23.98P/24P/	1 to 60P
		25P/29.97P/50P/59.94P	
		XAVC 3840 × 2160P	23.98P/25P/29.97P/59.94P
	XAVC 2048 × 1080P	23.98P/24P/29.97P/59.94P	1 to 180P*
		25P/50P	1 to 150P*
	XAVC 1920 × 1080P	23.98P/29.97P/59.94P	1 to 180P*
		25P/50P	1 to 150P*

\* Setting value is 1 to 60 when “High Frame Rate Mode” is set to “Off.”

\*\* When recording on AXS and SxS simultaneously, the setting value is for SxS.

### Notes

- Slow & Quick Motion mode cannot be used while recording, playing, or displaying thumbnail.
- Slow & Quick Motion mode cannot be used while the Slow Shutter mode.
- Audio cannot be recorded while in the Slow & Quick Motion mode.
- When “High Frame Rate Mode” is set to “Full Scan” and the frame rate is set to more than 61P, moiré may occur in high resolution areas of the picture. In this case, you can reduce moiré by attaching an optional CBK-55F2K Optical 2K Filter.
- When “High Frame Rate Mode” is set to other than “Off,” the camcorder cannot switch to the second card automatically even if a card becomes full.
- Slow & Quick Motion function is not possible in Interval Rec and Picture Cache mode. The camcorder exits Interval Rec and Picture Cache mode whenever you select Slow & Quick Motion mode. The camcorder exits Slow & Quick Motion mode

automatically whenever you select Interval Rec or Picture Cache mode.

## Recording Time-lapse Video (Interval Rec Function)

The camcorder’s Interval Rec function allows you to capture time-lapse videos to the camcorder’s internal memory. This function is an effective way to shoot slow-moving subjects. When “Setting” in “Interval Rec” (page 84) of the Recording menu is set to “On,” and you start recording, the camcorder automatically records a specified number of frames at a specified interval time.

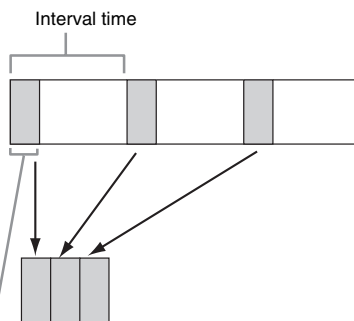

Number of frames in one take

The Interval Rec function is available when “Main Operation,” “Rec Control,” and the recording format are set to the following settings.

Main Operation	Rec Control	Recording format
RAW	AXS	–
	SxS & AXS	XAVC 2048 × 1080P XAVC 1920 × 1080P
RGB	–	XAVC 2048 × 1080P XAVC 1920 × 1080P
YPbPr	–	XAVC 4096 × 2160P XAVC 3840 × 2160P XAVC 2048 × 1080P XAVC 1920 × 1080P

### Notes

- The Interval Rec function cannot be used at the same time as the Slow & Quick Motion or Picture Cache function. When you select Interval Rec mode, the Slow & Quick Motion and Picture Cache functions are disabled. When you select Slow & Quick Motion or Picture Cache mode, the Interval Rec function is disabled.

- The simultaneously recording function is not available in Internal Rec mode.
- Interval Rec settings cannot be changed during recording.
- The following are limitations for the Interval Rec function.
  - Audio signals will not be recorded.
  - You cannot perform the Rec Review function.
  - The signal will not be unlocked.

## Starting to Record from Pre-stored Video (Picture Cache Function)

You can begin recording a specified number of seconds in advance by storing up to 15 seconds of video and audio data in the internal memory of the camcorder when you start recording. When you start recording after setting “Setting” in “Picture Cache Rec” (*page 84*) of the Recording menu to “On,” the camcorder records in advance of the specified time (Cache Rec Time).

The Picture Cache function is available for either of the following settings.

- The system frequency is set to 29.97/25/24/23.98, and the recording format is set to XAVC 4096 × 2160P/XAVC 3840 × 2160P/XAVC 2048 × 1080P/XAVC 1920 × 1080P.
- The recording format is set to MPEG 1920 × 1080P/MPEG 1920 × 1080i/MPEG 1280 × 720P.

The selected Picture Cache mode is retained until the setting is changed.

### Notes

- If the system frequency is set to 29.97, 25, 24, or 23.98, the “Cache Rec Time” setting is limited depending on the recording format.
  - For XAVC 4096 × 2160P, XAVC 3840 × 2160P: Locked to “0-2sec.”
  - For XAVC 2048 × 1080P, XAVC 1920 × 1080P: “8-10sec” and “13-15sec” cannot be selected.
- Picture cache recording is not possible in Slow & Quick Motion and Interval Rec mode. The camcorder exits Slow & Quick Motion and Interval Rec mode whenever you select Picture Cache mode. The camcorder exits Picture Cache mode automatically whenever you select Slow & Quick Motion or Interval Rec mode.
- The data stored in picture cache memory is cleared when you change system settings, such as the recording format. Picture data from before the change is not recorded even if you start recording immediately

after the change. The camcorder exits Picture Cache mode automatically.

- The simultaneously recording function is not available in Picture Cache mode.
- It is not possible to change the picture cache setting during recording.
- It is not possible to change the setting of the viewfinder double speed drive function during recording.

## Simultaneously Recording

You can record the two sizes of pictures simultaneously on an SxS memory card in one slot. You can also record HD signal on the SxS memory card in the camcorder while recording picture and audio of RAW format on the AXS-R5.

### Note

While simultaneously recording, the camcorder cannot switch to the second card automatically even if a card becomes full.

## Recording simultaneously on one memory card – MPEG2 Proxy function

For the PMW-F55, set “Setting” in “MPEG2 Proxy” (*page 84*) of the Recording menu to “On” while the recording format is set to XAVC 4096 × 2160/XAVC 3840 × 2160 29.97P/25P/23.98P, or SStP SR-SQ 444/SStP SR-SQ 422 59.94i/29.97P.

For the PMW-F5, by installing the optional CBKZ-55FX, the MPEG2 Proxy function is available while the recording format is set to XAVC 4096 × 2160/XAVC 3840 × 2160 29.97P/25P/23.98P.

The picture of XAVC 4096 × 2160/XAVC 3840 × 2160 or SStP SR-SQ 444/SStP SR-SQ 422, and the picture signal of MPEG2 1920 × 1080 are recorded simultaneously on one SxS memory card.

The clip of XAVC 4096 × 2160/XAVC 3840 × 2160 or SStP SR-SQ 444/SStP SR-SQ 422 is recorded under the XDROOT/Clip directory on the SxS memory card, but the clip of MPEG2 1920 × 1080 is recorded under the XDROOT/Sub directory on the SxS memory card, and the suffix “S02” is added to the end of the clip name.

### Notes

- This function cannot be used while in the Slow & Quick Motion, Interval Rec, or Picture Cache Rec mode.

- The MLUT setting is locked to “MLUT On” for the MPEG2 Proxy video that is recorded simultaneously when in the Cine EI mode.

## Recording on the AXS and SxS memory simultaneously

Set “Setting” in “Rec Control” (*page 84*) of the Recording menu to “SxS & AXS,” while “Main Operation” in “Base Setting” (*page 90*) of the System menu is set to “RAW.”

You can simultaneously record pictures of RAW format and pictures with formats set by “Rec Format.”

## Rec Review

You can review the last recorded clip on the screen (Rec Review) by assigning the Rec Review function to an assignable button (*page 43*).

When you stop recording and press the assigned button, the last 2 seconds of the clip are played. When you press and hold the button for more than 1 second, the camcorder starts to rewind from two seconds before of the last frame of the clip at 4x speed. When you release the button, the camcorder starts playback at that point.

Rec Review stops at the end of the clip, then resumes STBY (recording standby) status.

### Note

The Setup menus cannot be operated during Rec Review.

## Focus Magnifier

By pressing the FOCUS MAG button of the viewfinder (DVF-L350, DVF-EL100, DVF-L700) that is attached to the camcorder, you can expand the center part of the viewfinder, and it is easy to adjust the focus. After adjusting the focus, press the button again to return to the normal (recording) screen.

It does not affect the recorded image or output signal in the focus magnifier mode.

## False Color Display

You can perform the false color display on the viewfinder by pressing the SPARE button of the viewfinder (DVF-EL100, DVF-L700) that is attached to the camcorder.

*For details about the false color display, refer to the operating instructions of the DVF-EL100 or DVF-L700.*

### Note

The false color display is available only when the “Gamma” setting for the video signal that is output to the viewfinder is set to “S-Log2.”

## Viewfinder Double Speed Drive Function

If the system frequency is 23.98P, 24P, 25P, or 29.97P, the image may be blurred and hard to see because of low frame frequency when you shoot while swaying the camcorder to the right and the left.

In this case, you can decrease image blur and make it easier to see by activating the viewfinder double speed drive function.

To activate, set “Double Speed Drive” in “VF Setting” (*page 80*) of the VF menu to “On.”

### Notes

- This function is not effective on the following settings.
  - System frequency is 59.94/50.
  - Recording format is SSiP SR-SQ 444/SSiP SR-Lite 422/SSiP SR-SQ 422.
  - “Setting” in “Slow Shutter” of the Camera menu is set to “On.”
  - “Setting” in “S&Q Motion” of the Camera menu is set to “On,” and the “Frame Rate” setting is 1 to 60P.
- When this function is effective and “Setting” in “S&Q Motion” of the Camera menu is set to “Off,” the electronic shutter function is locked to on, and the shutter angle is limited to 180 degrees.

# Thumbnail Screens

When you press the Thumbnail button of the sub display (*page 17*), clips recorded on the SxS memory card are displayed as thumbnails on the screen.

You can start playback from the clip selected on the thumbnail screen. The playback picture can be seen on the viewfinder screen and external monitors.

Press the Thumbnail button of the sub display to exit the thumbnail screen and return to the recording screen.

## Configuration of the Screen

Information for the clip selected with the cursor are displayed at the bottom of the screen.

The icon of the current SxS memory card is highlighted, shading the nonselected one. (If the card is write-protected, a lock icon is displayed to the left.)

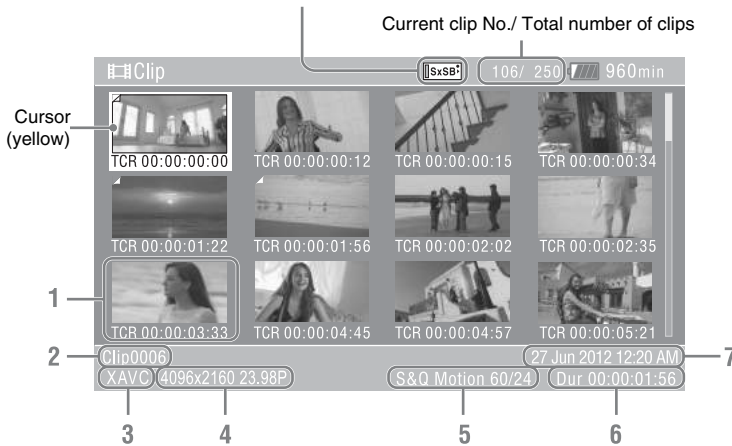

### 1. Thumbnail

The thumbnail image for each clip is an index frame from the clip. When recording, the first frame of a clip is automatically set as the index frame.

Below each thumbnail, the clip/frame information is displayed. You can change the displayed item on “Thumbnail Caption” in “Customize View” (*page 48*) of the thumbnail menu.

### 2. Clip name/title

The clip name or title of the selected clip is displayed.

### 3. File format

The file format of the selected clip is displayed.

### 4. Recording video format

### 5. Special recording information

If the selected clip was recorded in a special recording mode, the mode is displayed.

Clips recorded in Slow & Quick Motion display the frame rate to the right.

### 6. Duration of the clip

### 7. Creation date and time

## Playing Clips

### Playing the Selected and Subsequent Clips in Sequence

- 1 Turn the MENU dial (*page 11*) to move the cursor to the thumbnail image of the clip with which you wish to start playback.
- 2 Press the MENU dial.  
Playback starts from the beginning of the selected clip.

#### Notes

- To start playback by pressing the MENU dial, set “Set Key on Thumbnail” in “Switch/Lamp” (*page 93*) of the System menu to “Play.”
- The playback picture may be momentarily distorted or frozen between clips. You cannot operate the camcorder during this condition.
- When you select a clip on the thumbnail screen and start playback, the playback picture at the beginning of the clip may be distorted. To start playback without distortion, pause playback once after starting it, press the Prev button on the sub display (VIEW-1) to return to the top of the clip, then restart playback.

## Clip Operations

On the thumbnail screen, you can operate the clips or confirm the subsidiary data for clips using the thumbnail menu. The thumbnail menu appears when you press the OPTION button (*page 13*) on the thumbnail menu.

### Operations of the Thumbnail Menu

Turn the MENU dial (*page 11*) to select a menu item, then press the MENU dial. Pressing the CANCEL/BACK button (*page 11*) restores to the previous condition. Pressing the OPTION button while the thumbnail menu is displayed turns the thumbnail menu off.

#### Notes

- When the SxS memory card is write-protected, some operations are unavailable.
- There may be items that cannot be selected, depending on the status when the menu is displayed.

---

### Clip operation menu

---

#### Display Clip Properties

Displays the detailed information of a clip screen (*page 49*).

#### Copy MPEG2 Proxy (PMW-F55 and PMW-F5 + CBKZ-55FX)

Copy All Clips: Copies all the MPEG2 Proxy data to the destination media as a clip (*page 49*).

#### Delete Clip

Select Clip: Deletes the selected clip (*page 50*).

#### Customize View

Thumbnail Caption: Changes the items that are displayed under the thumbnail screen. (*page 50*)



## Displaying the Detailed Information of a Clip

Select “Display Clip Properties” from the thumbnail menu.

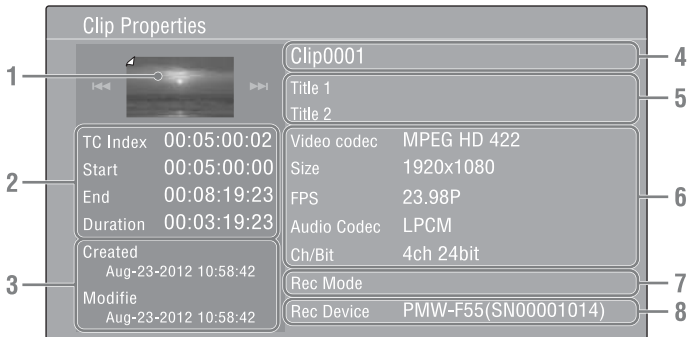

### 1. Image of the current clip

### 2. Timecode

TC Index: Timecode of the displayed frame  
Start: Timecode at the recording starting point  
End: Timecode at the recording ending point  
Duration: Duration of the clip

### 3. Date of recording/modifying

### 4. Clip name

### 5. Clip title 1/2

### 6. Recording format

Video Codec: Video codec  
Size: Picture size  
FPS: Frame rate  
Audio Codec: Audio codec  
Ch/Bit: Number of the recorded audio channel/  
audio recording bit

### 7. Special recording information

### 8. Recording device name

## Copying MPEG2 Proxy Data (PMW-F55 and PMW-F5 + CBKZ-55FX)

You can copy all the MPEG2 Proxy data recorded on the clip to another SxS memory card as a clip. Each clip is copied to the destination SxS memory card and given the same name as the MPEG2 Proxy data with its suffix “S02” deleted.

### Notes

- If there is another clip having the same name on the destination SxS memory card, the clip is copied under a name adding a single-digit number in parentheses to the end of the original clip name. The parenthetical number is the minimum value that does not exist in the destination memory card.  
**Examples:**  
ABCD0002(1) if ABCD0002 exists  
ABCD0002(2) if ABCD0002(1) exists  
ABCD0005(4) if ABCD0005(3) exists
- You cannot copy a file 1000 times or more if clips with the same clip name followed by parenthetical numbers (1) to (999) already exist on the card.
- A warning message is displayed if there is not sufficient space on the destination SxS memory card. Replace the SxS memory card with one with sufficient space.

## Deleting Clips

You can delete clips from the SxS memory card. Select “Select Clip” from “Delete Clip” on the thumbnail menu.

You can select multiple clips to be deleted. Press the OPTION button (*page 13*) after selecting the clip to be deleted.

## Changing Information on the Thumbnail Screen

You can change information of the clip/frame that is displayed under thumbnail.

Select the displayed item from “Thumbnail Caption” in “Customize View” on the thumbnail menu.

Date Time: Creation date or modified time

Time Code: Timecode

Duration: Duration

Sequential Number: Thumbnail number

## Sub Display Operation

You can check the status of the camcorder, set basic settings for the camcorder, and operate playback on the sub display.

- CAMERA screen: Basic settings of the camcorder
- FILE screen: Loading the file
- AU/TC screen: Settings for audio or timecode
- VIEW screen: Playback and operation on the thumbnail screen

For details about the screen of the sub display, see “Sub Display Screen” (page 17) in “On-Screen Indications.”

### Controls

#### Function buttons (page 14)

Switches the screen of the sub display.

If there are multiple screens for a function, press the function button repeatedly.

- CAMERA button
- FILE button
- AU/TC (audio/timecode) button
- VIEW button

#### Item button (page 14)

Selects the item of the sub display.

#### SEL/SET dial (MENU dial) (page 11)

When you turn it, the cursor moves in the corresponding direction, permitting you to select menu items or setting values.

Press the MENU dial to select the item.

#### CANCEL/BACK button (page 11)

To return to the previous layer of the menu. An uncompleted change is canceled.

#### Note

When the setup menu is being displayed by pressing the MENU button (page 13), or the status display is being displayed by pressing the STATUS button (page 12), you cannot operate other than the VIEW screen.

### Setting the basic items

- 1 Press the function button to select the screen of the function to be set.
- 2 Press the item button to select the item to be set.  
Setting value of the item that can be set is orange.
- 3 Turn the MENU dial to move the cursor to the item to be set.

S&Q FPS 24FPS	Shutter 1/180.0	Color Temp 3200K
On >	320min 4096x2160	0 1 2 3 4 5 6 7 8 9
Off	00:00 23.98P	10 20 30 40 50 60 70 80 90
Reel: A001	Shot: C001	XAVC
AXS 60 min	SxSA 60 min	SxSB 60 min
Sensitivity ISO 800	Gamma S-Log2	

- 4 Press the MENU dial to enter the selected item.

### Using the sub display as the operation button

Press the VIEW button (page 14) to display the VIEW-1/VIEW-2 screen (page 18), then operate the displayed function with the item button. The cursor operation on the sub display is used on the setup menu (page 56) and the clip operation (page 48).

# Sub Display Setting Items

The item names and its settings are listed below.

## Note

When the CBK-55BK (EFP Style Buildup Kit) is attached to the camcorder, some operations and settings are limited.

## CAMERA Screen

### CAMERA-1

Item name	Setting
<b>S&amp;Q FPS</b>	On: Turns the Slow & Quick motion mode on, and sets the frame rate. (See <i>page 66</i> for the selectable item.) Off: Turns the Slow & Quick motion mode off.
<b>Shutter</b>	Sets the electronic shutter speed and shutter angle. Select from following 11 types of items. Off: Turns the electronic shutter function off. Value of Step Shutter: Selects from 8 types of presets that are registered as Step Shutter. (You can change the preset value after selecting.) Continuous: Selects the available speed/angle. (See <i>page 64</i> for the selectable item.) SLS: Selects the slow shutter function. (Set the number of frames to accumulate after selecting.)  <b>When the CBK-55BK is attached</b> The SHUTTER switch on the CBK-55BK takes priority. If the SHUTTER switch is set to OFF, "Value of Step Shutter" and "Continuous" cannot be selected. If the SHUTTER switch is set to ON, "Off" cannot be selected.
<b>Color Temp</b>	Sets the color temperature of the white balance. Preset 3200K/4300K/5500K: Sets the white balance to the preset value of color temperature 3200K/4300K/5500K. Memory A/Memory B: Sets the color temperature of the white balance that is stored on the white memory A or B.  <b>Note</b> "Memory A"/"Memory B" cannot be selected when "Shooting Mode" ( <i>page 90</i> ) is set to "Cine EI."  <b>When the CBK-55BK is attached</b> The WHITE BAL switch on the CBK-55BK takes priority. When "Shooting Mode" ( <i>page 90</i> ) is set to "Custom," "Preset 3200K/4300K/5500K," and "Memory A/Memory B" cannot be changed on the sub display. If the WHITE BAL switch is set to PRST, "Memory A/Memory B" cannot be selected. If the WHITE BAL switch is set to A or B, only the color temperature of the white balance that is stored on the white memory on each Memory A/Memory B can be set. If "Shooting Mode" is set to "Cine EI," the preset value can be selected from Preset 3200K/4300K/5500K for each position of the WHITE BAL switch.

Item name	Setting
<b>Sensitivity/Gain/ Exposure Index</b>	Sets the sensitivity/gain. The item name (Sensitivity/Gain) and setting value differ, depending on the “Mode” setting in “Gain” (page 61). (See page 61 for the selectable item.) The item name becomes “Exposure Index” and sets the EI value when “Shooting Mode” (page 90) is set to “Cine EI.” (See page 62 for the selectable item.) User Gamma: Selects the user gamma. (User1 / User2 / User3 / User4 / User5)
<b>When the CBK-55BK is attached</b>	
You can select the setting value for each position (L/M/H) of the GAIN/EI switch on the CBK-55BK. The GAIN switch position is displayed on the left of the setting value.	
<b>Gamma/High Latitude</b>	Sets the gamma category and gamma table. STD: Selects the standard gamma. STD1 DVW / STD2 $\times 4.5$ / STD3 $\times 3.5$ / STD4 240M / STD5 R709 / STD6 $\times 5.0$ HG: Selects the hyper gamma. HG1 3250G36 / HG2 4600G30 / HG3 3259G40 / HG4 4609G33 / HG7 8009G40 / HG8 8009G33 S-Log2: Selects S-Log2. S-Log3: Selects S-Log3.
<b>Note</b>	
“High Latitude” is displayed when “Shooting Mode” (page 90) is set to “Cine EI.”	
<b>MLUT</b>	Selects and sets LUT/Look Profile. (See page 78 for the selectable item.)

## CAMERA-2

Item name	Setting
<b>Color Bars</b>	Turns the color bars on/off.
<b>Auto White</b>	Performs the auto white balance function. (This setting is available only when “White Switch” is set to “Memory A/Memory B.”)
<b>Auto Black</b>	Performs the auto black balance function.
<b>Sub&amp;HDMI</b>	Selects whether to apply monitor LUT for the output image from SDI (Sub) and HDMI when “Shooting Mode” (page 90) is set to “Cine EI.”
<b>Viewfinder</b>	Selects whether to apply monitor LUT for the viewfinder image when “Shooting Mode” (page 90) is set to “Cine EI.”
<b>SDI (Sub) Disp.</b>	Select whether to output the character information and marker to the SDI (Sub) output.

## FILE Screen

### FILE-1

Item name	Setting
<b>All File Load 1 to 6</b>	Loads the All file (1 to 6) from the SD card that is inserted into the SD card slot.

### FILE-2

Item name	Setting
<b>Scene Recall 1 to 5/ Standard</b>	Loads the Scene file (1 to 5, or Standard) from the internal memory.

Item name	Setting
<b>Lens Recall 1 to 6</b>	Loads the Lens file (1 to 6) from the internal memory.

## AU/TC (audio/timecode) Screen

### AU/TC-1

Item name	Setting
<b>MIC CH1 Ref</b>	<p>Select the reference input level when the AUDIO IN CH1 switch is set to MIC from -60 dB/-50 dB/-40 dB.</p> <p><b>When the CBK-55BK is attached</b> The item name is changed to "Rear MIC1 Ref;" and sets the reference level when the AUDIO IN CH-1 switch on the rear of the CBK-55BK is set to MIC (select from -70 dB/-60 dB/-50 dB/-40 dB/-30 dB).</p>
<b>CH1 Input</b>	<p>Auto: Adjusts the recording level automatically. Manual: Adjust the recording level manually from -99 to +99.</p> <p><b>Note</b> If the AES/EBU signal is selected for the audio input signal, the recording level is locked.</p> <p><b>When the CBK-55BK is attached</b> This item does not appear because the setting of this item follows the settings of the AUDIO SELECT CH-1 switch and position of the LEVEL CH-1 knob on the CBK-55BK.</p>
<b>CH1 Select</b>	<p>Displays the input source for AUDIO IN CH1.</p> <p><b>When the CBK-55BK is attached</b> The input source of AUDIO IN CH-1 on the rear of the CBK-55BK is displayed.</p>
<b>MIC CH2 Ref</b>	<p>Select the reference input level when the AUDIO IN CH2 switch is set to MIC from -60 dB/-50 dB/-40 dB.</p> <p><b>When the CBK-55BK is attached</b> The item name is changed to "Rear MIC2 Ref;" and sets the reference level when the AUDIO IN CH-2 switch on the rear of the CBK-55BK is set to MIC (select from -70 dB/-60 dB/-50 dB/-40 dB/-30 dB).</p>
<b>CH2 Input</b>	<p>Auto: Adjusts the recording level automatically. Manual: Adjust the recording level manually from -99 to +99.</p> <p><b>Note</b> If the AES/EBU signal is selected for the audio input signal, the recording level is locked.</p> <p><b>When the CBK-55BK is attached</b> This item does not appear because the setting of this item follows the settings of the AUDIO SELECT CH-2 switch and position of the LEVEL CH-2 knob on the CBK-55BK.</p>
<b>CH2 Select</b>	<p>Displays the input source for AUDIO IN CH2.</p> <p><b>When the CBK-55BK is attached</b> The input source of AUDIO IN CH-2 on the rear of the CBK-55BK is displayed.</p>

## AU/TC-2

Item name	Setting
<b>Monitor CH</b>	Selects the audio channel that is output to the headphones and speaker. (See page 75 for the selectable item.)  <b>When the CBK-55BK is attached</b> The status of the MONITOR switch on the CBK-55BK is displayed.
<b>Monitor Level</b>	Adjusts the monitor volume from 0 to 99.  <b>When the CBK-55BK is attached</b> This item does not appear because the setting of the item is adjusted on the MONITOR knob on the CBK-55BK.

## AU/TC-3

Item name	Setting
<b>Display</b>	Switches the indication for the time data (Timecode/Duration).
<b>Reset</b>	Resets the timecode and counter to 00:00:00:00.
<b>Set</b>	Sets the timecode to the desired value.
<b>Mode</b>	Sets the timecode mode. Preset (Ext): Starts the timecode from the specified value. Int. Regen (regeneration): Starts the timecode from that of the previous clip.
<b>Run</b>	Sets the condition for the timecode. Rec Run: Advances the timecode during recording only. Free Run: Keeps advancing regardless of the state of recording.
<b>TC Source</b>	Displays the external lock status for the timecode. Internal: The timecode is not locked when "S&Q Motion" is set to "Off" and timecode is set to "Preset (Ext-Lk)" and "Free Run." External: The timecode is locked when "S&Q Motion" is set to "Off" and timecode is set to "Preset (Ext-Lk)" and "Free Run." No indication: Other than above.

# Setup Menu Operations

The Setup menu allowing you to perform various settings that are needed for recording and playing, appears on the viewfinder screen by pressing the MENU button. (You can display the Setup menu on the external video monitor or sub display.)

## Menu controls

### MENU button (page 13)

To turn the menu mode to use the setup menus on/off.

### SEL/SET dial (MENU dial) (page 11)

When you turn the dial, the cursor moves up or down, permitting you to select menu items or setting values.

Press the MENU dial to select the highlighted item.

### CANCEL/BACK button (page 11)

To return to the previous menu. An uncompleted change is canceled.

### Up/Down/Left/Right buttons, SET button (page 18)

When you press the up/down/left/right buttons on the sub display (VIEW-2), the cursor moves in the corresponding direction, permitting you to select menu items or setting values.

Press the SET button to enter the highlighted item.

#### Note

In the focus magnifier mode (page 46), the setup menu cannot be used.

## Setting the Setup menus

Turn the MENU dial to set the cursor to the item of the menu you wish to set, then press the MENU dial to select that item.

- The menu item selection area can show 9 lines at maximum. When all the selectable items cannot be displayed at one time, you can scroll the display up or down by moving the cursor.
- For items having a wide range of available values (example: -99 to +99), the available value area is not displayed. The current setting is highlighted instead, indicating that the setting is ready for change.

- When you select “Execute” for an execution item, the corresponding function is executed.
- When you select an item that you must confirm before execution, the menu display temporarily disappears, and a confirmation message is displayed. Follow the instructions of the message, and specify whether to execute or cancel.

## Entering a character string

When you select an item for which a character string, such as a filename, is to be specified, the character input screen appears.

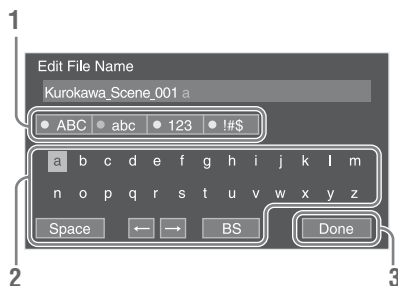

### 1 Select character type by turning the MENU dial, then press the MENU dial to enter.

ABC: Uppercase alphabetical  
abc: Lowercase alphabetical  
123: Numerical  
!#\$: Special

### 2 Select a character from the selected character type.

The cursor moves to the next column.  
Space: Inputs space on the position of the cursor.  
←/→: Moves the cursor.  
BS: Deletes a character on the left of the cursor.

### 3 Select “Done” after inputting characters.

The input characters are entered and the character input screen disappears.



## User Menu

The User Menu consists of the items that are copied from the Camera, Paint, Audio, Video, VF, TC/UB, Recording, Media, File, Maintenance, and System menu. By registering the highly-used items in advance, you can easily recall the desired item.

You can register up to 20 items for the User Menu.

The following 10 items are registered for the default setting.

- System Setting (System menu)
- Base Setting (System menu)
- Rec Format (System menu)
- Rec Control (Recording menu)
- Output Format (Video menu)
- Monitor LUT (Video menu)
- Clip Naming (Media menu)
- VF Setting (VF menu)
- Assignable Button (System menu)
- Format Media (Media menu)

The User Menu consists of the following hierarchies.

First hierarchy	Second hierarchy	Third hierarchy	List of edit functions	Contents
User Menu	Registered item			Sets the item.
	Edit User Menu	Registered item	Delete	Deletes the item.
			Move	Moves the item.
			Edit Subitem	Edits the subitem.
		Add Item		Adds the item.
		Customize Reset		Returns the registration to the default.

The customized User Menu items can be stored on an SD Card as the User Menu Item file. You can load the User Menu items from the SD Card.

### Note

You cannot register double items/subitems and change the name of items/subitems.

## Editing the registered item

- 1 Display the User Menu of the setup menu.**

The registered items are displayed.
- 2 Select “Edit User Menu” from the User Menu.**
- 3 Select the item for editing.**

The list for edit functions is displayed.
- 4 Select the edit item.**

Delete: Deletes the selected item.  
Move: Moves the selected item. Move the ► mark to the desired position.  
Edit Subitem: Edits the subitem of the selected item. Select the subitem and decide registering/unregistering of the subitem by

performing the decision operation (selection/deselection of the checkbox). Select “OK” after setting.

## Adding items

- 1 Select the User Menu > “Edit User Menu” > “Add Item.”**

Items that can be registered to the User Menu are displayed.
- 2 Select the item that you want to register.**

The subitem editing display of the selected item is displayed.
- 3 Select registering/unregistering of the subitem.**

Select the subitem and decide registering/unregistering of the subitem by performing the decision operation (selection/deselection of the checkbox).
- 4 Select “OK.”**

The added item is displayed on the User Menu.

---

## Return the User Menu registration to the default setting

---

- 1** Select the User Menu > “Edit User Menu” > “Customize Reset.”
- 2** Select “Reset” > “Execute.”

# Setup Menu List

The functions and available settings of menus are listed below.

The default settings set at the factory are shown in bold face (example: **Preset 3200K**).

## Note

If the CBK-55BK (EFP Style Buildup Kit) is attached to the camcorder, some items are added, and some operations and settings are limited.

## Camera Menu

Camera		
Menu items	Sub items and setting values	Contents
<b>White</b> Setting for white balance	Auto White Balance	Performs the auto white balance function.
	Execute / Cancel	Execute: Executes this function. (This setting is available only when "White Switch" is set to "Memory A/Memory B.")
	White Switch	Sets the operation mode for "White."
	<b>Preset 3200K</b> / Preset 4300K / Preset 5500K / Memory A / Memory B	Preset 3200K/4300K/5500K: Set the white balance to the preset value of the color temperature 3200K/4300K/5500K. Memory A/Memory B: Adjusts the white balance manually. Perform the auto white balance function (one push). ("Memory A/Memory B" is available only when "Shooting Mode" in "Base Setting" of the System menu is set to "Custom.")
		<b>When the CBK-55BK is attached</b> When "Shooting Mode" (page 90) is set to "Custom," this item is available only when the WHITE BAL switch on the CBK-55BK is set to PRST. "Preset 3200K/Preset 4300K/Preset 5500K" can be selected.
	Color Temp. 1500K to 50000K ( <b>3200K</b> )	Displays and sets the color temperature of white balance that is stored in the white memory. (This setting is available only when "White Switch" is set to "Memory A/Memory B.")
		<b>When the CBK-55BK is attached</b> This item is available only when "Shooting Mode" (page 90) is set to "Custom," and the WHITE BAL switch on the CBK-55BK is set to A or B, and displays/sets the color temperature of the white balance for each position (A or B).
	Color Temp. Balance -99 to +99 ( <b>±0</b> )	Sets the color temperature more precisely, if the result is not as you desire, even though you set "Color Temp." (This setting is available only when "White Switch" is set to "Memory A/Memory B.")
		<b>When the CBK-55BK is attached</b> This item is available only when "Shooting Mode" (page 90) is set to "Custom," and the WHITE BAL switch on the CBK-55BK is set to A or B, and displays/sets the white balance value for each position (A or B).

## Camera

Menu items	Sub items and setting values	Contents
	R Gain -99 to +99 (±0)	Sets the R gain value of white balance that is stored in the memory. (This setting is available only when “White Switch” is set to “Memory A/Memory B.”)  <b>When the CBK-55BK is attached</b> This item is available only when “Shooting Mode” (page 90) is set to “Custom,” and the WHITE BAL switch on the CBK-55BK is set to A or B, and displays/sets the white balance value for each position (A or B).
	B Gain -99 to +99 (±0)	Sets the B gain value of white balance that is stored in the memory. (This setting is available only when “White Switch” is set to “Memory A/Memory B.”)  <b>When the CBK-55BK is attached</b> This item is available only when “Shooting Mode” (page 90) is set to “Custom,” and the WHITE BAL switch on the CBK-55BK is set to A or B, and displays/sets the white balance value for each position (A or B).
	Shockless White Off / 1 / 2 / 3	Sets the speed of change in white balance when the white balance mode is switched. Off: Changes instantly. 1 to 3: Select a larger number to change the white balance more slowly through interpolation.
	Filter White Memory On / Off	Turns on/off “Filter White Memory” that sets the memory area of the white balance for each position number of the ND filter.
<b>Offset White</b> Setting for the offset white balance	Setting On / Off	Turns on/off “Offset White” that is for the auto white balance function (one push). (This setting is available only when “White Switch” is set to “Memory A/Memory B.”)
	Offset <Memory> -99 to +99 (±0)	Adjusts the volume of the offset white for the auto white balance function (one push). (This setting is available only when “White Switch” is set to “Memory A/Memory B.”)
<b>Black</b> Setting for the black	Auto Black Balance Execute / Cancel	Performs the auto black balance function. Execute: Executes this function.
	Master Black -99 to +99 (±0)	Sets the master black level. (This setting is available only when “Shooting Mode” in “Base Setting” of the System menu is set to “Custom.”)
	R Black -99 to +99 (±0)	Sets the R black level. (This setting is available only when “Shooting Mode” in “Base Setting” of the System menu is set to “Custom.”)
	B Black -99 to +99 (±0)	Sets the B black level. (This setting is available only when “Shooting Mode” in “Base Setting” of the System menu is set to “Custom.”)

Camera		
Menu items	Sub items and setting values	Contents
<b>Flare</b> Setting the flare correction	Setting <b>On</b> / Off	Turns the flare correction function on/off. (This setting is available only when “Shooting Mode” in “Base Setting” of the System menu is set to “Custom,” and this setting is locked to “Off” when “Shooting Mode” is set to “Cine EL.”)
	Master Flare -99 to +99 ( <b>±0</b> )	Sets the user adjustment value for master flare of the flare correction that is caused by the camcorder.
	R Flare -99 to +99 ( <b>±0</b> )	Sets the user adjustment value for R flare of the flare correction that is caused by the camcorder.
	G Flare -99 to +99 ( <b>±0</b> )	Sets the user adjustment value for G flare of the flare correction that is caused by the camcorder.
	B Flare -99 to +99 ( <b>±0</b> )	Sets the user adjustment value for B flare of the flare correction that is caused by the camcorder.
	<b>Gain</b> Setting for the Gain	Mode <b>ISO</b> / dB
Gain • PMW-F5 When “Mode” in “Gain” is set to “ISO,” and “Gamma Category” is set to “STD” or “HG (HG1/HG2/HG3/HG4)” <b>ISO 800</b> to ISO 6400 When “Mode” in “Gain” is set to “ISO,” and “Gamma Category” is set to “HG (HG7/HG8)” <b>ISO 1600</b> to ISO 12500 When “Mode” in “Gain” is set to “ISO,” and “Gamma Category” is set to “S-Log2” or “S-Log3” <b>ISO 2000</b> to ISO 16000 • PMW-F55 When “Mode” in “Gain” is set to “ISO,” and “Gamma Category” is set to “STD” or “HG (HG1/HG2/HG3/HG4)” <b>ISO 500</b> to ISO 4000 When “Mode” in “Gain” is set to “ISO,” and “Gamma Category” is set to “HG (HG7/HG8)” <b>ISO 1000</b> to ISO 8000 When “Mode” in “Gain” is set to “ISO,” and “Gamma Category” is set to “S-Log2” or “S-Log3” <b>ISO 1250</b> to ISO 10000 When “Mode” in “Gain” is set to “dB” -3dB / <b>0dB</b> / 3dB / 6dB / 9dB / 12dB / 18dB		Sets the gain. (This setting is available only when “Shooting Mode” in “Base Setting” of the System menu is set to “Custom.”) <b>When the CBK-55BK is attached</b> The setting value that follows the position of the GAIN/EI switch on the CBK-55BK is displayed.

Exposure Index • PMW-F5 500EI to 8000EI ( <b>2000EI</b> ) • PMW-F55 320EI to 5000EI ( <b>1250EI</b> )	Sets the EI value. (This setting is available only when “Shooting Mode” in “Base Setting” of the System menu is set to “Cine EI.”)
	<div style="background-color: #cccccc; padding: 2px;"><b>Note</b></div> The Highlight Latitude values for each EI value are follows: • PMW-F5 500EI: 4.0E / 640EI: 4.3E / 800EI: 4.7E / 1000EI: 5.0E / 1250EI: 5.3E / 1600EI: 5.7E / 2000EI: 6.0E / 2500EI: 6.3E / 3200EI: 6.7E / 4000EI: 7.0E / 5000EI: 7.3E / 6400EI: 7.7E / 8000EI: 8.0E • PMW-F55 320EI: 4.0E / 400EI: 4.3E / 500EI: 4.7E / 640EI: 5.0E / 800EI: 5.3E / 1000EI: 5.7E / 1250EI: 6.0E / 1600EI: 6.3E / 2000EI: 6.7E / 2500EI: 7.0E / 3200EI: 7.3E / 4000EI: 7.7E / 5000EI: 8.0E
	<div style="background-color: #cccccc; padding: 2px;"><b>When the CBK-55BK is attached</b></div>
	The setting value that follows the position of the GAIN/EI switch on the CBK-55BK is displayed.
Highlight Latitude 4.0E to 8.0E ( <b>6.0E</b> )	Displays the Highlight Latitude value according to the “Exposure Index” setting.
Gain/EI Switch <L> (Only when the CBK-55BK is attached)  See “Gain” or “Exposure Index” for the selectable items. Default setting: Same value as the “Gain” setting for “Custom,” “800EI” for “Cine EI”	Sets the L level of the GAIN/EI switch on the CBK-55BK.  <div style="background-color: #cccccc; padding: 2px;"><b>Note</b></div> When “Shooting Mode” in “Base Setting” of the System menu is set to “Custom,” the selectable items are same as the selections in “Gain.” When “Shooting Mode” in “Base Setting” of the System menu is set to “Cine EI,” the selectable items are same as the selections in “Exposure Index.”
Gain/EI Switch <M> (Only when the CBK-55BK is attached)  See “Gain” or “Exposure Index” for the selectable items. Default setting: Double the value of the default setting of “Gain” for “Custom,” same value as the default setting of “Exposure Index” for “Cine EI”	Sets the M level of the GAIN/EI switch on the CBK-55BK.  <div style="background-color: #cccccc; padding: 2px;"><b>Note</b></div> When “Shooting Mode” in “Base Setting” of the System menu is set to “Custom,” the selectable items are same as them in “Gain.” When “Shooting Mode” in “Base Setting” of the System menu is set to “Cine EI,” the selectable items are same as them in “Exposure Index.”
Gain/EI Switch <H> (Only when the CBK-55BK is attached)  See “Gain” or “Exposure Index” for the selectable items. Default setting: Four times the value of the default setting of “Gain” for “Custom,” Double the value of the default setting of “Exposure Index” setting for “Cine EI”	Sets the H level of the GAIN/EI switch on the CBK-55BK.  <div style="background-color: #cccccc; padding: 2px;"><b>Note</b></div> When “Shooting Mode” in “Base Setting” of the System menu is set to “Custom,” the selectable items are same as them in “Gain.” When “Shooting Mode” in “Base Setting” of the System menu is set to “Cine EI,” the selectable items are same as them in “Exposure Index.”

## Camera

Menu items	Sub items and setting values	Contents
	Remote Gain L -3dB / <b>0dB</b> / 3dB / 6dB / 9dB / 12dB / 18dB	Sets the gain switch L level for RM (such as RM-B150, etc.). (This setting is available only when "Shooting Mode" in "Base Setting" of the System menu is set to "Custom.")
	Remote Gain M -3dB / 0dB / 3dB / <b>6dB</b> / 9dB / 12dB / 18dB	Sets the gain switch M level for RM (such as RM-B150, etc.). (This setting is available only when "Shooting Mode" in "Base Setting" of the System menu is set to "Custom.")
	Remote Gain H -3dB / 0dB / 3dB / 6dB / 9dB / <b>12dB</b> / 18dB	Sets the gain switch H level for RM (such as RM-B150, etc.). (This setting is available only when "Shooting Mode" in "Base Setting" of the System menu is set to "Custom.")
	Shockless Gain On / <b>Off</b>	Turns the shockless gain function on/off.

**Camera**

Menu items	Sub items and setting values	Contents
<b>Shutter</b> Specifying operating conditions of the electronic shutter	Setting <b>On</b> / Off	Turns the electronic shutter function on/off.  <b>When the CBK-55BK is attached</b> The setting value that follows the position of the SHUTTER switch on the CBK-55BK is displayed.
	Mode <b>Speed</b> / Angle	Selects modes of the electronic shutter.
	Select <b>Step</b> / Continuous	Selects the setting method for the electronic shutter speed.
	Shutter Value	Sets the shutter speed/angle. Speed mode: Shutter speed Angle mode: Shutter angle. Setting value differs depending on the format setting and the "Select" setting in "Shutter."

When "Mode" is set to "Speed"

Format setting	Step	Continuous
59.94P	1/100 / 1/120 / 1/125 / 1/250 / 1/500 /	1/60 to 1/8000
59.94i	1/1000 / 1/2000 / 1/4000	1/60 to 1/7000
50P	1/60 / 1/100 / 1/120 / 1/125 / 1/250 /	1/50 to 1/7000
50i	1/500 / 1/1000 / 1/2000	
29.97P	1/50 / 1/60 / 1/120 / 1/125 / 1/250 /	1/30 to 1/8000
	1/500 / 1/1000 / 1/2000	
25P	1/30 / 1/50 / 1/60 / 1/100 / 1/250 /	1/25.02 to 1/7000
	1/500 / 1/1000 / 1/2000	When "S&Q Motion" is set to "On" 1/30 to 1/7000
24P	1/48 / 1/50 / 1/60 / 1/120 / 1/250 /	1/24.02 to 1/6000
	1/500 / 1/1000 / 1/2000	When "S&Q Motion" is set to "On" 1/30.02 to 1/6000
23.98P	1/48 / 1/50 / 1/60 / 1/120 / 1/250 /	1/23.99 to 1/6000
	1/500 / 1/1000 / 1/2000	When "S&Q Motion" is set to "On" 1/30.03 to 1/6000

When "Mode" is set to "Angle"

Format setting	Step	Continuous
59.94P	216.0 / 180.0 / 120.0 / 90.0 / 45.0 / 22.5 / 11.2 / 5.6	359.7 to 4.2
59.94i		
50P	300.0 / 180.0 / 150.0 / 90.0 / 45.0 / 22.5 / 11.2 / 5.6	
50i		
29.97P	216.0 / 180.0 / 120.0 / 90.0 / 45.0 / 22.5 / 11.2 / 5.6	
25P	300.0 / 180.0 / 150.0 / 90.0 / 45.0 / 22.5 / 11.2 / 5.6	
24P	180.0 / 172.8 / 144.0 / 90.0 / 45.0 / 22.5 / 11.2 / 5.6	
23.98P		

Step Select Execute / Cancel	Changes the preset value for "Shutter Value" (8 types) of the "Step" setting in "Select." Add: Adds a step shutter value. When 8 steps are already registered, delete a step shutter value by using "Delete" to make the space for adding the new step shutter value. Delete: Deletes a registered step shutter value. Step 1~8: Displays a registered step shutter value.
---------------------------------	---



Camera		
Menu items	Sub items and setting values	Contents
<b>Slow Shutter</b> Setting the slow shutter	Setting On / Off	Turns the slow shutter function on/off. (You cannot change the on/off setting while recording.)
	Number of Frames 2 / 3 / 4 / 5 / 6 / 7 / 8	Sets the number of frames to accumulate for the slow shutter.
<b>Auto Exposure</b> Setting the auto adjusting for the video level (This setting is available only for a lens that is compatible with the iris control function.)	Level +2.0 to -2.0 ( $\pm 0$ )	Sets the desired control level (bright/dark) for auto iris.
	Speed -99 to +99 ( $\pm 0$ )	Sets the control speed for auto iris.
	Clip High light On / Off	Turns on/off the function that makes dull the response for high luminance by ignoring the detection of high luminance area.
	Detect Window 1 to 6 (1)	Selects the type of the detect window.
	Detect Window Indication On / Off	Turns on/off the function that displays the frame of the detect window as a marker.

## Camera

Menu items	Sub items and setting values	Contents
<b>S&amp;Q Motion</b> Setting the Slow & Quick Motion function	Setting On / <b>Off</b>	Turns the Slow & Quick Motion function on/off. This setting is not available when “Rec Format” of the System menu is set to the following settings. <ul style="list-style-type: none"> <li>• MPEG 1920 × 1080/1280 × 720</li> <li>• SStP SR-SQ 444/422</li> <li>• SStP SR-Lite 422</li> </ul> (This setting is not available when “Main Operation” in “Base Setting” of the System menu is set to “RGB.”)
	High Frame Rate Mode <b>Off</b> / Full Scan / Center Scan	Sets the high speed shooting method more than 60P. Off: High speed shooting is not performed. Full Scan: Performs high speed shooting with the picture angle of Super 35 mm size. Center Scan: Performs high speed shooting with half size of picture angle of Super 35 mm size on the center area of a picture.
		<b>Note</b> When “Imager Scan Mode” in “Base Setting” of the System menu is set to “2K Full,” this setting is locked to “Full Scan.” When “Imager Scan Mode” in “Base Setting” of the System menu is set to “2K Center,” this setting is locked to “Center Scan.”
	Frame Rate 1 to 240 ( <b>24</b> )	Sets the frame rate for the Slow & Quick Motion recording.
		<b>Note</b> Available settings are follows. When “High Frame Rate Mode” is set to “Off” 1 to 60 (24) When “High Frame Rate Mode” is set to “Full Scan” or “Center Scan” <ul style="list-style-type: none"> <li>• When “Main Operation” in “Base Setting” of the System menu is set to “RAW,” and “Rec Control” of the Recording menu is set to “AXS”                —72, 75, 80, 90, 96, 100, 110, 120, 125, 135, 144, 150, 160, 168, 175, 180, 240</li> <li>• When “Main Operation” in “Base Setting” of the System menu is set to “RAW,” and “Rec Control” of the Recording menu is set to “SxS&amp;AXS”                —72, 75, 80, 90, 96, 100, 110, 120, 125, 135, 144, 150, 160, 168, 175, 180 (system frequency: 23.98/24/29.97/59.94)                —72, 75, 80, 90, 96, 100, 110, 120, 125, 135, 144, 150 (system frequency: 25/50)</li> <li>• When “Main Operation” in “Base Setting” of the System menu is set to “YPbPr”                —72, 75, 80, 90, 96, 100, 110, 120, 125, 135, 144, 150, 160, 168, 175, 180 (system frequency: 23.98/24/29.97/59.94)                —72, 75, 80, 90, 96, 100, 110, 120, 125, 135, 144, 150 (system frequency: 25/50)</li> </ul> (This setting is not available when “Main Operation” in “Base Setting” of the System menu is set to “RGB.”)

Camera		
Menu items	Sub items and setting values	Contents
<b>Color Bars</b> Setting the Color Bars	Setting <b>On / Off</b>	Turns the color bars on/off.
	Type <b>ARIB / SMPTE / 75% / 100%</b>	Selects the type of color bar.
<b>Noise Suppression</b> Setting the noise suppression	Setting <b>On / Off</b>	Turns the noise suppression function on/off. (The default settings is “Off” when “Shooting Mode” in “Base Setting” of the System menu is set to “Cine EI.”)
	Level <b>Low / Mid / High</b>	Sets the noise suppression level.
<b>Flicker Reduce Compensation</b>	Mode <b>Auto / On / Off</b>	Set the operation of the Flicker-Reduction function.
	Frequency <b>50 Hz / 60 Hz</b>	Set to the power supply frequency of the light source causing flicker.
<b>Image Inversion</b> Setting the image inversion function	Setting <b>Normal / V Inv</b>	Sets the image inversion.
<b>Lens Interface</b> Setting the lens interface	Setting Type C / Type A / Type C+12P / Type A+12P / <b>Off</b>	Selects the lens interface according to the connected lens type. When using an optional LA-FZB1/FZB2 mount adapter, select “Type C.” When using the lens mount adapter with Lens 12 pin (service parts), select “Type C+12P” or “Type A+12P.”
	Zoom Limit <b>Off / Zoom Range 1 / Zoom Range 2</b>	Sets the limit for the zoom operation range of the power zoom.

**Note**

If changing this setting while the lens attached to the camcorder, turn the camcorder off, then turn it on.

## Paint Menu

The Paint menu settings are available only when “Shooting Mode” in “Base Setting” (page 90) of the System menu is set to “Custom.”

Paint		
Menu items	Sub items and setting values	Contents
Gamma Adjusting the gamma compensation	Setting <b>On / Off</b>	Turns the gamma compensation function on/off.
	Step Gamma 0.35 to 0.90 ( <b>0.45</b> )	Sets the gamma compensation value in 0.05 steps.
	Master Gamma -99 to +99 ( <b>±0</b> )	Adjusts the master gamma level.
	R Gamma -99 to +99 ( <b>±0</b> )	Adjusts the R gamma level.
	G Gamma -99 to +99 ( <b>±0</b> )	Adjusts the G gamma level.
	B Gamma -99 to +99 ( <b>±0</b> )	Adjusts the B gamma level.
	Gamma Category <b>STD</b> / HG / User / S-Log2 / S-Log3	Select from among “STD” (standard gamma), “HG” (hyper gamma), “User” (user gamma), “S-Log2,” or “S-Log3.”
	Gamma Select	Selects the gamma table that is used for the gamma compensation.
	When “Gamma Category” is set to “STD” STD1 DVW / STD2 ×4.5 / STD3 ×3.5 / STD4 240M / <b>STD5 R709</b> / STD6 ×5.0	
	When “Gamma Category” is set to “HG” HG1 3250G36 / HG2 4600G30 / HG3 3259G40 / <b>HG4 4609G33</b> / HG7 8009G40 / HG8 8009G33	
When “Gamma Category” is set to “User” <b>User 1</b> / User 2 / User 3 / User 4 / User 5		
When “Gamma Category” is set to “S-Log2” <b>S-Log2</b>		
When “Gamma Category” is set to “S-Log3” <b>S-Log3</b>		
Black Gamma Adjusting the black gamma compensation	Setting <b>On / Off</b>	Turns the black gamma compensation function on/off. (This setting is available only when “Gamma Category” in “Gamma” of the Paint menu is set to “STD.”)
	Range <b>LOW / HIGH</b>	Selects the black gamma correction effective range. LOW: 0 to 3.6% HIGH: 0 to 28.8%
	Master Black Gamma -2 to +2 ( <b>±0</b> )	Sets the master black gamma level.

Paint		
Menu items	Sub items and setting values	Contents
<b>Knee</b> Adjusting the knee compensation	Setting <b>On / Off</b>	Turns the knee compensation function on/off. (This setting is available only when “Gamma Category” in “Gamma” is set to “STD.”)
	Point 75% to 109% ( <b>90%</b> )	Sets the knee point.
	Slope -99 to +99 ( <b>±0</b> )	Sets the knee slope.
	Knee Saturation <b>On / Off</b>	Turns the knee saturation function on/off.
	Knee Saturation Level -99 to +99 ( <b>±0</b> )	Adjusts the knee saturation level.
<b>White Clip</b> Adjusting the white clipping	Setting <b>On / Off</b>	Turns the white clipping adjustment on or off. (This setting is available only when “Gamma Category” in “Gamma” is set to “STD” or “HG.”)
	Level	Sets the white clip level.  When the system frequency setting is 59.94, 29.97, or 23.98. 90.0% to 109.0% ( <b>108.0%</b> ) When the system frequency setting is 50, 25, or 24. 90.0% to 109.0% ( <b>105.0%</b> )

Paint		
Menu items	Sub items and setting values	Contents
<b>Detail</b> Setting the detail adjusting	Setting <b>On / Off</b>	Turns the detail adjusting function on/off.
	Level -99 to +99 ( $\pm 0$ )	Adjusts the detail level.
	H/V Ratio -99 to +99 ( $\pm 0$ )	Adjusts the ratio between the H detail level and V detail level.
	Crispening -99 to +99 ( $\pm 0$ )	Adjusts the crispening level.
	Level Depend <b>On / Off</b>	Turns the level depend adjustment function on/off.
	Level Depend Level -99 to +99 ( $\pm 0$ )	Adjusts the level depend level.
	Frequency -99 to +99 ( $\pm 0$ )	Sets the center frequency of the H details signal. (Setting the center frequency higher decreases the details.)
	Knee Aperture <b>On / Off</b>	Turns the knee aperture compensation function on/off.
	Knee Aperture Level -99 to +99 ( $\pm 0$ )	Adjusts the knee aperture level.
	Limit -99 to +99 ( $\pm 0$ )	Adjusts both the white and black detail limiter.
	White Limit -99 to +99 ( $\pm 0$ )	Adjusts the white detail limiter.
	Black Limit -99 to +99 ( $\pm 0$ )	Adjusts the black detail limiter.
	V Black Limit -99 to +99 ( $\pm 0$ )	Adjusts the black V detail limiter.
	V Detail Creation NAM / <b>Y</b> / G / G+R	Selects the source signal to generate the V detail signal. NAM: Highest level signal of V detail signal that is generated by R signal, G signal, or B signal. Y: Y signal G: G signal G+R: Synthesized signal from G and R signal with a same ratio.
<b>Aperture</b> Setting the aperture compensation	Setting <b>On / Off</b>	Turns the aperture compensation function on/off.
	Level -99 to +99 ( $\pm 0$ )	Adjusts the aperture level.

Paint		
Menu items	Sub items and setting values	Contents
<b>Skin Detail</b> Adjusting the skin detail compensation	Setting <b>On / Off</b>	Turns the skin detail compensation function on/off.
	Area Detection Execute/Cancel	Detects the color for the skin detail compensation. Execute: Executes this function.
	Area Indication <b>On / Off</b>	Turn on/off the function that displays the zebra pattern in the target area for the skin detail compensation.
	Level -99 to +99 ( $\pm 0$ )	Adjusts the skin detail level.
	Saturation -99 to +99 ( $\pm 0$ )	Adjusts the color (saturation) level for the skin detail compensation.
	Hue <b>0</b> to 359	Adjusts the color hue for the skin detail compensation.
	Width 0 to 90 ( <b>40</b> )	Adjusts the width of the color hue for the skin detail compensation.
	<b>Matrix</b> Setting of the Matrix correction	Setting <b>On / Off</b>
Preset Matrix <b>On / Off</b>		Turns the preset matrix function on/off.
Preset Select		Selects the preset matrix.
• PMW-F5: <b>Standard</b> / High Saturation / FL Light / Cinema / F55 709 Like		
• PMW-F55: 1: SMPTE240M / 2: <b>ITU-709</b> / 3: SMPTE Wide / 4: NTSC / 5: EBU / 10: S-Gamut3.Cine Like / 11: S-Gamut3 Like		
User Matrix <b>On / Off</b>		Turns the user matrix correction function on/off.
Level -99 to +99 ( $\pm 0$ )		Adjusts the color saturation for the entire picture area.
Phase -99 to +99 ( $\pm 0$ )		Adjusts the color phase for the entire picture area.
User Matrix R-G -99 to +99 ( $\pm 0$ )		Finely adjusts the color phase for the entire picture area by independently setting each of the factors.
User Matrix R-B -99 to +99 ( $\pm 0$ )		
User Matrix G-R -99 to +99 ( $\pm 0$ )		
User Matrix G-B -99 to +99 ( $\pm 0$ )		
User Matrix B-R -99 to +99 ( $\pm 0$ )		
User Matrix B-G -99 to +99 ( $\pm 0$ )		

**Paint**

<b>Menu items</b>	<b>Sub items and setting values</b>	<b>Contents</b>
<b>Multi Matrix</b> Settings for the multi-matrix correction	Setting On / <b>Off</b>	Turns on/off the multi-matrix correction, which allows specific colors to be selected for saturation correction in a 16-axis hue space.
	Area Indication On / <b>Off</b>	Displays a zebra pattern in the areas of the specified color for multi-matrix correction.
	Color Detection Execute/Cancel	Detects the target color on the screen for multi-matrix correction. Execute: Executes this function.
	Axis <b>B</b> / B+ / MG- / MG / MG+ / R / R+ / YL- / YL / YL+ / G- / G / G+ / CY / CY+ / B-	Specifies a color targeted by multi-matrix correction (16-axis mode).
	Hue -99 to +99 ( <b>±0</b> )	Sets the color hue of the color targeted by multi-matrix correction for each 16-axis mode.
	Saturation -99 to +99 ( <b>±0</b> )	Sets the saturation of the color targeted by multi-matrix correction for each 16-axis mode.



# Audio Menu

## Audio

Menu items	Sub items and setting values	Contents
<b>Audio Input</b> Setting for audio inputs	Front MIC Select (Only when the CBK-55BK is attached)	Selects the front microphone sound from either monaural and stereo.
	Mono / <b>Stereo</b>	
<b>Note</b> This item cannot be selected when removing the audio connector panel.	Rear XLR Auto (Only when the CBK-55BK is attached)	Turn on/off the function that detects audio cable connection for the AUDIO IN connector on the rear of the CBK-55BK automatically. On: Detects the audio cable connection automatically. REAR is selected for AUDIO CH-1 or AUDIO CH-2 input signal in spite of the setting of the AUDIO IN switch on the CBK-55BK. Off: Selects the input signal by following the setting of the AUDIO IN switch on the CBK-55BK.
	On / <b>Off</b>	
	Front MIC CH1 Ref (Only when the CBK-55BK is attached)	Selects the reference input level of CH-1 for the front microphone on the CBK-55BK.
	-70dB / -60dB / <b>-50dB</b> / -40dB / -30dB	
	Front MIC CH2 Ref (Only when the CBK-55BK is attached)	Selects the reference input level of CH-2 for the front microphone on the CBK-55BK.
	-70dB / -60dB / <b>-50dB</b> / -40dB / -30dB	
	Rear MIC CH1 Ref (Only when the CBK-55BK is attached)	Selects the reference input level for when the AUDIO IN CH-1 switch on the rear of the CBK-55BK is set to MIC.
	-70dB / -60dB / <b>-50dB</b> / -40dB / -30dB	
	Rear MIC CH2 Ref (Only when the CBK-55BK is attached)	Selects the reference input level for when the AUDIO IN CH-2 switch on the rear of the CBK-55BK is set to MIC.
	-70dB / -60dB / <b>-50dB</b> / -40dB / -30dB	
	MIC CH1 Ref -60dB / <b>-50dB</b> / -40dB	Selects the reference input level for when the AUDIO IN CH1 switch is set to MIC.
		<b>Note</b> This item is not displayed when the CBK-55BK is attached.
	MIC CH2 Ref -60dB / <b>-50dB</b> / -40dB	Selects the reference input level for when the AUDIO IN CH2 switch is set to MIC.
		<b>Note</b> This item is not displayed when the CBK-55BK is attached.
	Line Input Ref (Only when the CBK-55BK is attached)	Selects the reference input level for when the AUDIO IN CH-1/CH-2 switch on the rear of the CBK-55BK is set to LINE.
	0dB / <b>+4dB</b> / -3dB / EBUL	

## Audio

### Menu items    Sub items and setting values    Contents

Limiter Mode <b>Off</b> / -6dB / -9dB / -12dB / -15dB / -17dB	Selects the limiter level when a loud signal is input while setting audio input level manually. When you do not use the limiter, select "Off."
1KHz Tone on Color Bars On / <b>Off</b>	Turn the 1-kHz reference tone signal on/off.
CH-1 Wind Filter On / <b>Off</b>	Turn the wind filter for the channel 1 on/off.
CH-2 Wind Filter On / <b>Off</b>	Turn the wind filter for the channel 2 on/off.
CH-3 Wind Filter (Only when the CBK-55BK is attached) On / <b>Off</b>	Turn the wind filter for the channel 3 on/off.
CH-4 Wind Filter (Only when the CBK-55BK is attached) On / <b>Off</b>	Turn the wind filter for the channel 4 on/off.
MIC CH1 Level (Only when the CBK-55BK is attached) Side1 / <b>Front</b> / Front+Side1	Select the knob for adjusting when recording the sound from the front microphone on the CBK-55BK to CH-1. Side1: LEVEL CH-1 knob on the audio operating section Front: MIC LEVEL knob on the operating section (front) Front+Side1: LEVEL CH-1 knob and MIC LEVEL knob (interlocked)
MIC CH2 Level (Only when the CBK-55BK is attached) Side2 / <b>Front</b> / Front+Side2	Select the knob for adjusting when recording the sound from the front microphone on the CBK-55BK to CH-2. Side2: LEVEL CH-2 knob on the audio operating section Front: MIC LEVEL knob on the operating section (front) Front+Side2: LEVEL CH-2 knob and MIC LEVEL knob (interlocked)
Rear1/WRR Level (Only when the CBK-55BK is attached) <b>Side1</b> / Front / Front+Side1	Select the knob for adjusting the sound from the wireless microphone attached to the CBK-55BK or device connected to the AUDIO IN CH-1 connector on the rear of the CBK-55BK. Side1: LEVEL CH-1 knob on the audio operating section Front: MIC LEVEL knob on the operating section (front) Front+Side1: LEVEL CH-1 knob and MIC LEVEL knob (interlocked)
Rear2/WRR Level (Only when the CBK-55BK is attached) <b>Side2</b> / Front / Front+Side2	Select the knob for adjusting the sound from the wireless microphone attached to the CBK-55BK or device connected to the AUDIO IN CH-2 connector on the rear of the CBK-55BK. Side2: LEVEL CH-2 knob on the audio operating section Front: MIC LEVEL knob on the operating section (front) Front+Side2: LEVEL CH-2 knob and MIC LEVEL knob (interlocked)
Audio CH3 Level (Only when the CBK-55BK is attached) <b>Side3</b> / Front / Front+Side3	Select the knob for adjusting the audio level of sound recorded to channel 3. Side3: LEVEL CH-3 knob on the audio operating section Front: MIC LEVEL knob on the operating section (front) Front+Side3: LEVEL CH-3 knob and MIC LEVEL knob (interlocked)

Audio		
Menu items	Sub items and setting values	Contents
	Audio CH4 Level (Only when the CBK-55BK is attached) <b>Side4</b> / Front / Front+Side4	Select the knob for adjusting the audio level of sound recorded to channel 4. Side4: LEVEL CH-4 knob on the audio operating section Front: MIC LEVEL knob on the operating section (front) Front+Side4: LEVEL CH-4 knob and MIC LEVEL knob (interlocked)
<b>Audio Level</b> Setting for audio recording level	CH-1 Audio Select <b>Auto</b> / Manual	The audio recording level is adjusted automatically when you set to "Auto."
	CH-2 Audio Select <b>Auto</b> / Manual	The audio recording level is adjusted automatically when you set to "Auto."
<b>Notes</b> <ul style="list-style-type: none"> <li>This item cannot be selected when removing the audio connector panel.</li> <li>The recording level for the channel that the AES/EBU signal is selected is locked.</li> </ul>	CH-1 Audio Level -99 to +99 ( $\pm 0$ )	Adjusts the audio recording level when "CH-1 Audio Select" is set to "Manual."
	CH-2 Audio Level -99 to +99 ( $\pm 0$ )	Adjusts the audio recording level when "CH-2 Audio Select" is set to "Manual."
	AGC Spec <b>-6dB</b> / -9dB / -12dB / -15dB / -17dB	Selects the AGC level.
	CH1&2 AGC Mode <b>Mono</b> / Stereo	Selects auto adjusting method for the input level of an analog audio signal recorded to CH-1/CH-2 from "Mono" (performs for each channel) and "Stereo" (performs in stereo mode).
	CH3&4 AGC Mode (Only when the CBK-55BK is attached) <b>Mono</b> / Stereo	Selects auto adjusting method for the input level of an analog audio signal recorded to CH-3/CH-4 from "Mono" (performs for each channel) and "Stereo" (performs in stereo mode).
	Reference Level (Only when the CBK-55BK is attached) <b>-20dB</b> / -18dB / -16dB / -12dB / EBUL	Sets the reference output level for 1 kHz test signal.
<b>Audio Output</b> Setting for audio outputs	Output CH <b>CH-1/CH-2</b> CH-3/CH-4	Selects audio output channels from either channels 1 and 2 or channels 3 and 4. <b>Note</b> This item cannot be set when the CBK-55BK is attached.
	Monitor CH  When "Output CH" is set to "CH1/CH2" <b>CH-1/CH-2</b> CH-1 CH-2  When "Output CH" is set to "CH3/CH4" <b>CH-3/CH-4</b> CH-3 CH-4	Selects the audio channel(s) to be fed to the headphones and the built-in speaker. CH-1/CH-2 (CH-3/CH-4): Stereo CH-1 (CH-3): CH-1 (CH-3) only CH-2 (CH-4): CH-2 (CH-4) only <b>Note</b> This item cannot be set when the CBK-55BK is attached.
	Headphone Out Mono / <b>Stereo</b>	Selects the headphones output, "Mono" or "Stereo."
	Monitor Level <b>0</b> to 99	Adjusts the monitor level. <b>Note</b> This item cannot be set when the CBK-55BK is attached.

## Audio

Menu items	Sub items and setting values	Contents
	Reference Out (Only when the CBK-55BK is attached) +4dB / <b>0dB</b> / -3dB / EBUL	Sets the output level for the reference input level of the LIVE AUDIO OUT connector on the CBK-55BK.
<b>WRR Setting</b> Setting related to the wireless receiver (Only when the CBK-55BK is attached)	WRR Valid CH Sel <b>All</b> / CH1	Selects whether to enable channels 1 and 2 of the wireless receiver ("All") or channel 1 only ("CH1"). All: Enables channels 1 and 2. CH1: Enables channel 1 only. (Select when using as the monaural wireless receiver.)
	WRR CH Select <b>TX1</b> / TX2	Specifies the target channel for menu display. TX1: Displays channel 1. TX2: Displays channel 2.
	WRR Delay Comp <b>On</b> / Off	Enables delay compensation for wireless audio input. Off: Disables. On: Enables. (The audio in all E-E output is delayed by about 8 ms.)
	TX	Displays the name of the transmitter of which signals are being received on the channel selected by "WRR CH Select."
	TX Audio Peak --- / Peak	Displays whether the AF level of the transmitter of which signals are being received on the channel selected by "WRR CH Select" are peaking.
	TX Input Level --- / Mic / Line	Displays whether the input level of the transmitter of which signals are being received on the channel selected by "WRR CH Select" is set to MIC or LINE.
	TX ATT Level	Sets the ATT level of the transmitter of which signals are being received on the channel selected by "WRR CH Select." (The setting range varies depending on the transmitter.)
	TX LCF Frequency	Sets the low cut filter frequency of the transmitter of which signals are being received on the channel selected by "WRR CH Select." (The setting range varies depending on the transmitter.)
TX System Delay <b>Auto</b> / 0.0ms to 8.0ms	Specifies the amount of audio delay for the channel selected by "WRR CH Select." Auto: Automatically adjusts the amount of delay so that the delay in the audio received from the wireless transmitter is zero. 0.0ms to 8.0ms: Sets the amount of anticipated wireless system delay, for cases in which several wireless systems are being used over a devices such as an audio mixer.	

## Video Menu

Video		
Menu items	Sub items and setting values	Contents
<b>Output On/Off</b> Setting the video output	SDI (Sub) <b>On / Off</b>	Turns the SDI (Sub) output on/off.
	HDMI <b>On / Off</b>	Turns the HDMI output on/off.
<b>Output Format</b> Setting for the output format	SDI (Main)	Selects the SDI (Main) output format. The setting value differs, depending on the settings of “Frequency” in “System Setting” and “Rec Format” of the System menu ( <i>page 101</i> ).
	SDI (Sub)	Selects the SDI (sub) output format. The setting value differs, depending on the settings of “Frequency” in “System Setting” of the System menu and “SDI (Main)” in “Output Format” of the Video menu ( <i>page 101</i> ).
	HDMI	Selects the HDMI output format. The setting value differs, depending on the settings of “Frequency” in “System Setting” and “Rec Format” of the System menu ( <i>page 105</i> ).
	EXT IF	Displays the extend IF output signal.
	Test	Displays the video output signal.
<b>Output Setting</b> Setting for the output conversion mode	4K/2K to HD Conv. <b>Letter Box</b> / Edge Crop / Anamo ×1.3 / Anamo ×2	Sets the picture frame for YPbPr format video signal. Letter Box / Edge Crop: Sets the output conversion mode for 17:9 → 16:9 signal. (This setting is available only when “Format” in “Rec Format” of the System menu is set to “XAVC 4096 × 2160P” or “XAVC 2048 × 1080P.”) Anamo ×1.3 / Anamo ×2: Corrects the distortion of the images that are output from the video output when using an anamorphic lens. (This setting is available only when “Main Operation” in “Base Setting” of the System menu is set to “RAW.”)
	SD Mode Letter Box / Edge Crop / <b>Squeeze</b>	Sets the output mode (aspect) for the SD signal.

### Note

The HD output signal when “Main Operation” in “Base Setting” of the System menu is set to “RAW,” or the internal recorded signal when “Setting” in “Rec Control” of the Recording menu is set to “SxS & AXS,” is “Letter Box”-equivalent signal.

## Video

Menu items	Sub items and setting values	Contents
<b>Monitor LUT</b> Setting for the monitor LUT	Category <b>LUT</b> / Look Profile / User 3D LUT	Selects the type of Look for Monitor LUT. LUT: Outputs images using Preset LUT or User LUT. Look Profile: Outputs images that are suited for the start point of color grading or images that are close to print quality by selecting the Look number. User 3D LUT: Outputs images using User 3D LUT. (This setting is available only when “Color Space” in “Base Setting” of the System menu is set to “S-Gamut3.Cine/SLog3” or “S-Gamut3/SLog3.”)
	LUT Select <b>P1: 709 (800%)</b> P2: HG8009G40 P3: HG8009G33 P4: S-Log2 P5: S-Log3 U1 U2 U3 U4 U5 U6	Selects the type of LUT when “Category” in “Monitor LUT” is set to “LUT.” 709 (800%): Signals, for which the dynamic range is expanded up to 800%, by using ITU-R709 as a standard. HG8009G40: Signals, for which the dynamic range is 800%, white limit is 109%, and use hyper gamma, for which video output with 18% gray card is 40%. HG8009G33: Signals, for which the dynamic range is 800%, white limit is 109%, and use hyper gamma, for which video output with 18% gray card is 33%. S-Log2: Log signal with 1300% dynamic range, for which the post production process should be performed, and visibility for Video Monitor is considered. (This setting is available only when “Color Space” in “Base Setting” of the System menu is set to “S-Gamut/SLog2.” The color space is set to S-Gamut.) S-Log3: Log signal with 1300% dynamic range, which is close to Cineon Log curve, and the characteristics of film. (This setting is available only when “Color Space” in “Base Setting” of the System menu is set to “S-Gamut3.Cine/SLog3” or “S-Gamut3/SLog3.” The color space is set to S-Gamut3.) U1 to U6: Any LUT signal that is imported from an SD card.
	Look Profile Select <b>1: LC-709</b> 2: LC-709typeA 3: SLog2-709 4: Cine+709	Selects the type of Look Profile when “Category” in “Monitor LUT” is set to “Look Profile.”
	User 3D LUT Select <b>User 3D-1</b> / User 3D-2 / User 3D-3 / User 3D-4	Selects the 3D LUT signal that is imported from an SD Card.
	SDI (Main) & Internal Rec MLUT On / <b>MLUT Off</b>	Selects whether to apply Monitor LUT to the image that is output from SDI (Main) and recorded on an SxS memory card. (When “Main Operation” is set to “RGB,” this setting is locked to “MLUT Off.”)

Video		
Menu items	Sub items and setting values	Contents
	SDI (Sub) & HDMI MLUT On / <b>MLUT Off</b>	Selects whether to apply Monitor LUT to the image that is output from SDI (Sub) and HDMI. (This setting is in accord with the “SDI (Main) & Internal Rec” setting, while the S&Q Motion or viewfinder double speed drive function is activated, or during RAW playback.)* * This setting for the HDMI output follows the “SDI (Main) & Internal Rec” setting when the SDI output format is set to 4K/QFHD and the HDMI output is set to 2K/HD. This setting is locked to “MLUT On” when the HDMI output is set to 2K/HD.
	Viewfinder MLUT On / <b>MLUT Off</b>	Selects whether to apply Monitor LUT to the viewfinder image. (This setting is in accord with the “SDI (Main) & Internal Rec” setting, while the S&Q Motion or viewfinder double speed drive function is activated, or during RAW playback.)* * This setting is locked to “MLUT On” when the SDI output format is set to 4K/QFHD.
<b>Output Display</b> Setting for the output signal	VF Out On / Off	Selects whether to overlaps characters and markers on the viewfinder output signal.
	4K/QFHD SDI/HDMI Out (PMW-F55 only) On / <b>Off</b>	Selects whether to overlaps characters and markers on the SDI or HDMI output signal when the picture size of SDI or HDMI output is 4K/QFHD.
	HD/SD SDI (Sub) Out On / Off	Selects whether to overlaps characters and markers on the SDI (Sub) output signal when the SDI (Sub) output picture quality is less than HD.
	HD/SD HDMI Out On / <b>Off</b>	Selects whether to overlaps characters and markers on the HDMI output signal when the HDMI output picture quality is less than HD.
	Forced Menu Disp <b>VF</b> / SDI/HDMI / Sub Display	Selects the output that displays the menu by pressing MENU even if the Output Display setting for each output is set to off. VF: Viewfinder that is connected to the VF (viewfinder output) connector. SDI/HDMI: Monitor that is connected to the SDI OUT3, SDI OUT4 (Sub), or HDMI OUT connector. Sub Display: Sub display screen.
	<b>Note</b>	The menu is not displayed on the sub display when this item is set to “VF” or “SDI/HDMI.”

## VF Menu

When there is a button or dial that corresponds to the menu item on the attached viewfinder, that item is not available.

VF		
Menu items	Sub items and setting values	Contents
<b>VF Setting</b> Setting the viewfinder	Color -99 to +99 ( $\pm 0$ )	Adjusts the color of pictures on the viewfinder.
	Contrast -99 to +99 ( $\pm 0$ )	Adjusts the contrast of pictures on the viewfinder.
	Brightness -99 to +99 ( $\pm 0$ )	Adjusts the brightness of pictures on the viewfinder.
	Color Mode <b>Color</b> / B&W	Selects the display mode of the viewfinder while E-E display/recording.
	Aspect <b>Auto</b> / Full / Anamo $\times 1.3$ / Anamo $\times 2$	Selects the displayed area of pictures for the viewfinder. Anamo $\times 1.3$ / Anamo $\times 2$ : Corrects the distortion of the images on the viewfinder screen when using an anamorphic lens. (This setting is available only when "Main Operation" in "Base Setting" of the System menu is set to "RAW.")
	Double Speed Drive On / <b>Off</b>	Turns on/off the function that doubles the frame rate for the viewfinder display when the system frequency is 23.98, 24, 25, or 29.97. (When this function is set to "On," the settable range for "Shutter Value" in "Shutter" of the Camera menu is limited to 180 degrees for the shutter angle.)
<b>Peaking</b> Setting the peaking function	Setting On / <b>Off</b>	Turns the peaking function on/off.
	Peaking Type <b>Normal</b> / Color	Selects the peaking type. Normal: Normal peaking. Color: Color peaking.
	Frequency <b>Normal</b> / High	Selects the peaking frequency from "Normal" (normal frequency) or "High" (high frequency).
	Normal Peaking Level 0 to 99 ( <b>50</b> )	Sets the normal peaking level.
	Color <b>B&amp;W</b> / Red / Yellow / Blue	Selects the color of the peaking signal when "Peaking Type" is set to "Color."
	Color Peaking Level 0 to 99 ( <b>50</b> )	Sets the color peaking level.



VF		
Menu items	Sub items and setting values	Contents
<b>Marker</b> Setting the marker indications	Setting <b>All / VF / SDI/HDMI / Off</b>	Turns all marker indications on the viewfinder on/off.
	Color <b>White / Yellow / Cyan / Green / Magenta / Red / Blue</b>	Sets the marker color.
	Center Marker <b>1 / 2 / 3 / 4 / Off</b>	Selects the center marker type when displaying the center marker. Select "Off" to turn off the center marker.
	Safety Zone <b>On / Off</b>	Turns the safety zone marker on/off.
	Safety Area <b>80% / 90% / 92.5% / 95%</b>	Selects the size (ratio to the entire screen) of the safety zone marker.
	Aspect Marker <b>Line / Mask / Off</b>	Selects the aspect marker. Line: To show white lines Mask: To lower the video signal level of areas outside the marker range. Off: To not display.
	Aspect Select <b>4:3 / 13:9 / 14:9 / 15:9 / 16:9 / 17:9 / 1.66:1 / 1.85:1 / 2.35:1 / 2.4:1</b>	Select the ratio of the aspect marker.
	Aspect Mask <b>0 to 15 (12)</b>	When "Aspect Marker" is set to "Mask," select the brightness of images outside the aspect marker.
	Aspect Safety Zone <b>On / Off</b>	Turns the aspect safety zone marker on/off.
	Aspect Safety Area <b>80% / 90% / 92.5% / 95%</b>	Selects the size (ratio to the entire screen) of the aspect safety zone marker.
	User Box <b>On / Off</b>	Turns the box cursor indication on/off.
	User Box Width <b>3 to 479 (240)</b>	Sets the width of the rectangle for the user box.
	User Box Height <b>3 to 269 (135)</b>	Sets the height of the rectangle for the user box.
	User Box H Position <b>-476 to 476 (0)</b>	Sets the horizontal position of the user box.
	User Box V Position <b>-266 to 266 (0)</b>	Sets the vertical position of the user box.
100% Marker <b>On / Off</b>	Turns 100% marker on/off.	
<b>Zebra</b> Setting the zebra pattern	Setting <b>On / Off</b>	Turns the zebra function on/off.
	Zebra Select <b>1 / 2 / Both</b>	Select the zebra pattern(s) (Zebra 1, Zebra 2, or both of Zebra 1 and Zebra 2) to be displayed.
	Zebra1 Level <b>50% to 107% (70%)</b>	Sets the display level of zebra 1.
	Zebra1 Aperture Level <b>1% to 20% (10%)</b>	Sets the aperture level of zebra 1.
	Zebra2 Level <b>52% to 109% (100%)</b>	Sets the display level of zebra 2.

Menu items	Sub items and setting values	Contents
<b>Display On/Off</b> Selecting the items to be displayed	Setting <b>On / Off</b>	Turns all the indications of the viewfinder GUI on/off.
	Shutter Setting <b>On / Off</b>	Selects the item to be displayed on the viewfinder.
	ND Filter Position <b>On / Off</b>	<div style="background-color: #cccccc; padding: 2px; display: inline-block;"><b>Notes</b></div> <ul style="list-style-type: none"> <li>• “Video Signal Monitor” is available only when the HD signal can be output from SDI (Sub), “4K/2K to HD Conv.” in “Output Setting” of the Video menu is set to “Letter Box,” and “Aspect” in “VF Setting” of the VF menu is set to “Auto” or “Full.”</li> <li>• For the Waveform display of Video Signal Monitor, there is the scale at 0%, 25%, 50%, 75%, and 100% of the video level.</li> <li>• Video Signal Monitor is not displayed on the viewfinder when outputting a video signal that is different from the signal of SDI (Sub) to the viewfinder.</li> </ul>
	Gain Setting <b>On / Off</b>	
	Rec/Play Status <b>On / Off</b>	
	Color Temp. <b>On / Off</b>	
	Frame Rate / Interval <b>On / Off</b>	
	Battery Remain <b>On / Off</b>	
	Timecode <b>On / Off</b>	
	Audio Level Meter <b>On / Off</b>	
	Media Status <b>On / Off</b>	
	Focus Position <b>Meter / Feet / Off</b>	
	Iris Position <b>On / Off</b>	
	Zoom Position <b>On / Off</b>	
	AE Mode <b>On / Off</b>	
	White Balance Mode <b>On / Off</b>	
	SDI Rec Control <b>On / Off</b>	
	Rec Format <b>On / Off</b>	
	Gamma <b>On / Off</b>	
	Timecode Lock <b>On / Off</b>	
	Wi-Fi Condition <b>On / Off</b>	
	Video Signal Monitor <b>Off / Waveform / Vector / Histogram</b>	
	Clip Name <b>On / Off</b>	
	Focus Assist Indicator <b>On / Off</b>	

**VF****Menu items    Sub items and setting values    Contents**

Focus Area Marker

On / **Off**

Clip Number

**On** / Off

Notice Message

**On** / Off

WRR RF Level

On / **Off****TC/UB Menu****TC/UB****Menu items    Sub items and setting values    Contents****Timecode**

Setting the timecode

Mode

**Preset (Ext-Lk)** / Int Regen

Selects the timecode mode.

Preset: To start the timecode from the specified value

Regen (regeneration): To start the timecode by continuing the timecode of the previous clip.

Run

**Rec Run** / Free Run

Rec Run: To advance the timecode during recording only.

Free Run: The timecode keeps advancing regardless of the state of recording.

Setting

Sets the timecode to a desired value.

SET: Sets the value.

Reset

Execute / Cancel

Resets the timecode to 00:00:00:00.

Execute: Execute this function.

TC Format

**DF** / NDF

Selects the timecode format.

DF: Drop frame

NDF: Non drop frame

**TC Display**

Setting the time data indication

Display Select

**Timecode** / Duration

Switches the time data indication.

# Recording Menu

## Recording

Menu items	Sub items and setting values	Contents
<b>Interval Rec</b> Setting the Interval Rec function	Setting On / Off	Turns the Interval Rec function on/off.
	Interval Time 1 to 10 / 15 / 20 / 30 / 40 / 50 sec 1 to 10 / 15 / 20 / 30 / 40 / 50 min 1 / 2 / 3 / 4 / 6 / 12 / 24 hour	Sets the interval for Interval Rec.
	Number of Frames	Specifies the number of frames to record in one Interval Rec take. When "Format" in "Rec Format" of the System menu is set to XAVC 50P or 59.94P: 2 / 6 / 12 frames When "Format" in "Rec Format" of the System menu is set to XAVC 23.98P, 24P, 25P, 29.97P, 50i, or 59.94i: 1 / 3 / 6 / 9 frames
<b>Picture Cache Rec</b> Setting the Picture Cache Rec function	Setting On / Off	Turns the Picture Cache Rec function on/off. (This setting is available only when "Main Operation" in "Base Setting" of the System menu is set to "YPbPr" or "RGB.")
	Cache Rec Time 0-2sec / 2-4sec / 4-6sec / 6-8sec / 8-10sec / 13-15sec	Sets the accumulated time to the picture cache memory (going back time when starting cache rec). (This setting is locked to "0-2sec" when "Format" in "Rec Format" of the System menu is set to "XAVC 4096 × 2160P" / XAVC 3840 × 2160P." "8-10sec" and "13-15sec" cannot be selected when "Format" in "Rec Format" of the System menu is set to "XAVC 2048 × 1080P" / "XAVC 1920 × 1080P.")
<b>MPEG2 Proxy</b> Setting the MPEG2 proxy function	Setting On / Off	Turns the MPEG2 proxy function on/off. (PMW-F55: This setting is available only when "Frequency" in "System Setting" of the System menu is set to "29.97"/"25"/"23.98" and "Format" in "Rec Format" of the System menu is set to "XAVC 4096 × 2160P" / "XAVC 3840 × 2160P;" or "Frequency" in "System Setting" of the System menu is set to "29.97" and "Format" in "Rec Format" of the System menu is set to "SSiP SR-SQ 444" / "SSiP SR-SQ 422." PMW-F5 + CBKZ-55FX: This setting is available only when "Frequency" in "System Setting" of the System menu is set to "29.97"/"25"/"23.98" and "Format" in "Rec Format" of the System menu is set to "XAVC 4096 × 2160P" / "XAVC 3840 × 2160P.")
	Setting SxS & AXS / AXS	Selects the recording target (only external recording (AXS memory), or both external recording (AXS memory) and recording to an SxS memory card in the camcorder) when "Main Operation" in "Base Setting" of the System menu is set to "RAW."
		<b>Note</b> Recording is not performed if the AXS memory disables recording even if "SxS & AXS" is set.
<b>SDI Rec Control</b> Setting the SDI recording control function	Setting Off / On	Turns on/off this function that controls recording/stop recording of the external device by the SDI output signal.

## Media Menu

This menu is not available when the media is not loaded.

Media		
Menu items	Sub items and setting values	Contents
<b>Update Media</b> Updating a memory	Media (A) Execute / Cancel	Updates the managerial file on the SxS memory card in the slot A. Execute: Updates the file.
	Media (B) Execute / Cancel	Updates the managerial file on the SxS memory card in the slot B. Execute: Updates the file.
	AXS Memory Execute / Cancel	Updates the managerial file on the AXS memory card. Execute: Updates the file.
<b>Format Media</b> Formatting a memory	Media (A) Execute / Cancel	Formats the SxS memory card in the slot A. Execute: Executes format.
	Media (B) Execute / Cancel	Formats the SxS memory card in the slot B. Execute: Executes format.
	SD card Execute / Cancel	Formats the SD card. Execute: Executes format.
	AXS Memory Execute / Cancel	Formats the AXS memory card. Execute: Executes format.
<b>Clip Naming</b> Setting for the clip name	Mode <b>Cam ID + Reel#</b> / Title	Sets the naming mode for the clip name. Cam ID + Reel#: Camera ID + Reel Number + Shot Number + date + random string Title: Any string that is set in "Title Prefix" + clip number
	Camera ID <b>A</b> to <b>Z</b>	Sets the camera ID when "Mode" is set to "Cam ID + Reel#."
	Reel Number <b>001</b> to 999	Sets the numeric portion of the Reel Number when "Mode" is set to "Cam ID + Reel#."
	Camera Position <b>C</b> / <b>L</b> / <b>R</b>	Sets the first character part of the Shot Number when "Mode" is set to "Cam ID + Reel#."
	Title Prefix	Sets the title part of the clip name when "Mode" is set to "Title." (Default setting is the unique ID for the model. Unique ID for the model: Lower three digits of the serial number.) (Input characters on the character input screen (page 56).)
	Number Set <b>0001</b> to 9999	Sets the number part of the clip name when "Mode" is set to "Title."

## File Menu

File		
Menu items	Sub items and setting values	Contents
<b>All File</b> Setting for the All file	Load SD Card	Loads the All file from the SD card that is inserted into the SD card slot.
	Save SD card	Stores the All file onto the SD card that is inserted into the SD card slot.
	File ID	Names the All file.
<b>Scene File</b> Setting for the Scene file (This setting is available only when “Shooting Mode” in “Base Setting” of the System menu is set to “Custom.”)	Recall Internal Memory	Loads the Scene file from the internal memory.
	Store Internal Memory	Stores the Scene file on the internal memory.
	Load SD Card	Loads the file from the sub memory card.
	Save SD Card	Stores the file on the sub memory card.
<b>User Menu Item</b> Setting for the User Menu Item file	File ID	Names the Scene file.
	Load SD Card	Loads the User Menu Item file from the SD card that is inserted into the SD card slot.
	Save SD Card	Stores the User Menu Item file onto the SD card that is inserted into the SD card slot.
<b>User Gamma</b> Setting for user gamma file	File ID	Names the User Menu Item file.
	Current Settings	Displays the name of the current user gamma file on the internal memory.
	Load SD Card	Loads the gamma table data (user gamma file) on an SD card that is made by user, to the internal memory. When using the user gamma file that is created on CvpFileEditorTM V4.2, store the file on the following directory of an SD card. PRIVATE\SONY\PROCAMERA\AHD_CAM
	Reset 1 / 2 / 3 / 4 / 5 / All Default value 1: 709 (800%) 2: S-Log2 3: 709 (800%) 4: 709 (800%) 5: 709 (800%)	Resets the user gamma file on the internal memory to the default value. 1 to 5: Selected file All: All files
<b>Monitor LUT</b> Setting for monitor LUT file	Current Settings	Displays 6 user LUT names that are registered in the internal memory.
	Load SD card 1 / 2 / 3 / 4 / 5 / 6	Loads the LUT data that is created by user on an SD card (user LUT file) to the internal memory. The user LUT file that is created on RAW Viewer is stored on the following directory of an SD card. PRIVATE\SONY\PROCAMERA\PMWF55_F5
	Reset 1 / 2 / 3 / 4 / 5 / 6 / All	Resets the user LUT data in the internal memory to the default value of “709(800%).” 1 to 6: Selected file All: All data

File		
Menu items	Sub items and setting values	Contents
<b>Monitor 3D LUT</b>	Current Settings	Displays the current user Monitor 3D LUT name in the internal memory.
Setting for monitor 3D LUT file	Load SD card 1 / 2 / 3 / 4	<p>Loads the 3D LUT data that is created by the user on an SD card (user 3D LUT file) to the internal memory.</p> <p>The camcorder can import the CUBE file (*.cube) of 17 or 33 lattices that is created by RAW Viewer or BMD's Da Vinci Resolve*.</p> <p>* Checked on Resolve V9.0 and V10.0.</p> <p>When creating the CUBE file, set "Input" to "S-Gamut3.Cine/S-Log3" and "Format" to "Resolve" (when creating by RAW Viewer).</p> <p>Store the created user 3D LUT file on the following directory of an SD card.</p> <p>PRIVATE\SONY\PRO\CAMERA\PMWF55_F5</p>
	Reset 1 / 2 / 3 / 4 / All	<p>Resets the user 3D LUT data in the internal memory to the default value of "LC-709."</p> <p>1 to 4: Selected file</p> <p>All: All data</p>

File		
Menu items	Sub items and setting values	Contents
<b>Lens File</b> Setting for the lens file (This setting is available only when “Shooting Mode” in “Base Setting” of the System menu is set to “Custom.”)	Recall Internal Memory	Loads the lens file from the internal memory.
	Store Internal Memory	Stores the lens file on the internal memory.
	Load SD Card	Loads the lens file from the sub memory card.
	Save SD Card	Stores the lens file on the sub memory card.
	File ID	Names the lens file.
	File Source	Displays the selected file number.
	Clear Lens Offset Execute / Cancel	Clear the lens file. Execute: Execute clearing.
	Lens Auto Recall <b>Off</b> / On (Lens Name) / On (Serial Number)	Sets whether to load the corresponding lens file automatically when the lens can be specified by lens communication.
		<b>Note</b>
		This function is available only when supplying power to the lens. (This function is not available after attaching/detaching the lens during supplying power to the lens.)
	Lens Serial Number	Displays the serial number of the lens that is attached to the camcorder, for lenses compatible with lens communication.
	Lens Name	Displays the lens model name when it can be obtained by lens communication.
	Lens Manufacturer	Displays the lens manufacturer name when it can be obtained by lens communication.
	Lens Center H -40 to +40 ( $\pm 0$ )	Sets the horizontal position of the center marker to the lens file.
	Lens Center V -40 to +40 ( $\pm 0$ )	Sets the vertical position of the center marker to the lens file.
	Flare R -99 to +99 ( $\pm 0$ )	Sets the user adjusting value of the R flare correction that is caused by the lens to the lens file.
	Flare G -99 to +99 ( $\pm 0$ )	Sets the user adjusting value of the G flare correction that is caused by the lens to the lens file.
	Flare B -99 to +99 ( $\pm 0$ )	Sets the user adjusting value of the B flare correction that is caused by the lens to the lens file.
	White Offset R -99 to +99 ( $\pm 0$ )	Sets the R ch correction value of the white balance offset by lens to the lens file.
	White Offset B -99 to +99 ( $\pm 0$ )	Sets the B ch correction value of the white balance offset by lens to the lens file.
Shading Ch Select <b>Red</b> / Green / Blue	Selects the channel for the white shading correction that is caused by the lens.	
Shading H SAW -99 to +99 ( $\pm 0$ )	Sets the Saw white shading correction value (caused by the lens) of the selected channel by “Shading Ch Select” and horizontal direction to the lens file.	
Shading H PARA -99 to +99 ( $\pm 0$ )	Sets the Para white shading correction value (caused by the lens) of the selected channel by “Shading Ch Select” and horizontal direction to the lens file.	
Shading V SAW -99 to +99 ( $\pm 0$ )	Sets the Saw white shading correction value (caused by the lens) of the selected channel by “Shading Ch Select” and vertical direction to the lens file.	
Shading V PARA -99 to +99 ( $\pm 0$ )	Sets the Para white shading correction value (caused by the lens) of the selected channel by “Shading Ch Select” and vertical direction to the lens file.	



## Maintenance Menu

### Maintenance

Menu items	Sub items and setting values	Contents
<b>APR</b> Executing APR	APR Execute / Cancel	Executes APR (Auto Pixel Restoration: auto adjusting of the image sensor).
<b>Test Saw</b> Setting the test signal output	Setting On / <b>Off</b>	Turns the test signal on/off.
<b>Camera Config</b> Detail settings for the camera	RM Common Memory On / <b>Off</b>	<p>Sets whether to share the settings of when connecting the remote control unit and using the camcorder alone.</p> <p><b>Note</b></p> <p>This item cannot be selected when connecting the remote control unit.</p>
	<p>HD/2K Modulation <b>High</b> / Low</p>	<p>Sets the video resolution of the HD/2K signal that is converted from the 4K/QFHD signal.</p> <p>High: High resolution that focuses details Low: Resolution equivalent to a conventional HD camera (such as F35, PMW-F3, etc.)</p> <p><b>Note</b></p> <p>This setting is for the HD/2K recording signal or HD/2K output signal when shooting while “Imager Scan Mode” is set to “Normal,” or the HD/2K output signal when playing the clip of XAVC 4096 × 2160/XAVC 3840 × 2160 or AXS memory (this setting is also applied to the viewfinder output signal).</p>

## System Menu

### System

Menu items	Sub items and setting values	Contents
<b>System Setting</b>	Frequency 59.94 / 50 / 29.97 / 25 / 24 / <b>23.98</b>	Selects the system frequency.
<b>Base Setting</b>	Shooting Mode <b>Custom</b> / Cine EI	Selects the shooting mode.
	Main Operation <b>YPbPr</b> / RGB / RAW	Sets the operation mode for recording mainly. (When “Shooting Mode” in “Base Setting” of the System menu is set to “Custom,” “YPbPr” or “RGB” can be selected.)
	Color Space S-Gamut/SLog2 / S-Gamut3.Cine/SLog3 / S-Gamut3/SLog3 / <b>Matrix</b>	Sets the color space. (When “Shooting Mode” in “Base Setting” of the System menu is set to “Custom,” “Matrix” can be selected. When “Shooting Mode” in “Base Setting” of the System menu is set to “Cine EI,” “S-Gamut/SLog2,” “S-Gamut3.Cine/SLog3,” or “S-Gamut3/SLog3” can be selected.)
	Imager Scan Mode <b>Normal</b> / 2K Full / 2K Center	Sets the reading mode of the imager. Normal: Shoots with 4K Super 35 mm size for normal recording. Shoots with 2K size for frame rate that is faster than 60P. 2K Full: Shoots with 2K Super 35 mm size. 2K Center: Shoots with the size equivalent to the Super 16 mm (center area of Super 35 mm).

System																																																									
Menu items	Sub items and setting values	Contents																																																							
<b>Rec Format</b> Setting the recording format	Format	Sets the video format to be recorded on the SxS memory card.																																																							
	XAVC 4096 × 2160P (PMW-F55 or PMW-F5 + CBKZ-55FX only)	The settable format for recording differs depending on the setting of “Frequency” in “System Setting” of the System menu and “Main Operation” in “Base Setting” of the System menu.																																																							
	XAVC 3840 × 2160P (PMW-F55 or PMW-F5 + CBKZ-55FX only)																																																								
	XAVC 2048 × 1080P																																																								
	XAVC 1920 × 1080P																																																								
	MPEG 1920 × 1080i																																																								
	MPEG 1280 × 720P																																																								
	SStP SR-SQ 444																																																								
	SStP SR-SQ 422																																																								
	SStP SR-Lite 422																																																								
	DNxHD 220x HD P/i*																																																								
	DNxHD 145 HD P/i*																																																								
	ProRes 422 HQ HD P/i*																																																								
ProRes 422 HD P/i*																																																									
	* When the CBK-55PD is applied.																																																								
	When system frequency is set to 59.94 or 50																																																								
	<table border="1"> <thead> <tr> <th rowspan="2">Recording format</th> <th colspan="3">Main Operation</th> </tr> <tr> <th>YPbPr</th> <th>RGB</th> <th>RAW**</th> </tr> </thead> <tbody> <tr> <td>XAVC 4096 × 2160P</td> <td>○</td> <td>–</td> <td>–</td> </tr> <tr> <td>XAVC 3840 × 2160P</td> <td>○</td> <td>–</td> <td>–</td> </tr> <tr> <td>XAVC 2048 × 1080P</td> <td>○</td> <td>○</td> <td>○</td> </tr> <tr> <td>XAVC 1920 × 1080P</td> <td>○</td> <td>○</td> <td>○</td> </tr> <tr> <td>MPEG 1920 × 1080i</td> <td>○</td> <td>○</td> <td>○</td> </tr> <tr> <td>MPEG 1280 × 720P</td> <td>○</td> <td>–</td> <td>–</td> </tr> <tr> <td>SStP SR-SQ 422</td> <td>○</td> <td>–</td> <td>–</td> </tr> <tr> <td>DNxHD 220x HD i</td> <td>○</td> <td>–</td> <td>–</td> </tr> <tr> <td>DNxHD 145 HD i</td> <td>○</td> <td>–</td> <td>–</td> </tr> <tr> <td>ProRes 422 HQ HD i</td> <td>○</td> <td>–</td> <td>–</td> </tr> <tr> <td>ProRes 422 HD i</td> <td>○</td> <td>–</td> <td>–</td> </tr> </tbody> </table>	Recording format	Main Operation			YPbPr	RGB	RAW**	XAVC 4096 × 2160P	○	–	–	XAVC 3840 × 2160P	○	–	–	XAVC 2048 × 1080P	○	○	○	XAVC 1920 × 1080P	○	○	○	MPEG 1920 × 1080i	○	○	○	MPEG 1280 × 720P	○	–	–	SStP SR-SQ 422	○	–	–	DNxHD 220x HD i	○	–	–	DNxHD 145 HD i	○	–	–	ProRes 422 HQ HD i	○	–	–	ProRes 422 HD i	○	–	–					
Recording format	Main Operation																																																								
	YPbPr	RGB	RAW**																																																						
XAVC 4096 × 2160P	○	–	–																																																						
XAVC 3840 × 2160P	○	–	–																																																						
XAVC 2048 × 1080P	○	○	○																																																						
XAVC 1920 × 1080P	○	○	○																																																						
MPEG 1920 × 1080i	○	○	○																																																						
MPEG 1280 × 720P	○	–	–																																																						
SStP SR-SQ 422	○	–	–																																																						
DNxHD 220x HD i	○	–	–																																																						
DNxHD 145 HD i	○	–	–																																																						
ProRes 422 HQ HD i	○	–	–																																																						
ProRes 422 HD i	○	–	–																																																						
	When system frequency is set to 29.97, 25, or 23.98																																																								
	<table border="1"> <thead> <tr> <th rowspan="2">Recording format</th> <th colspan="3">Main Operation</th> </tr> <tr> <th>YPbPr</th> <th>RGB</th> <th>RAW**</th> </tr> </thead> <tbody> <tr> <td>XAVC 4096 × 2160P</td> <td>○</td> <td>–</td> <td>–</td> </tr> <tr> <td>XAVC 3840 × 2160P</td> <td>○</td> <td>–</td> <td>–</td> </tr> <tr> <td>XAVC 2048 × 1080P</td> <td>○</td> <td>○</td> <td>○</td> </tr> <tr> <td>XAVC 1920 × 1080P</td> <td>○</td> <td>○</td> <td>○</td> </tr> <tr> <td>MPEG 1920 × 1080P</td> <td>○</td> <td>○</td> <td>○</td> </tr> <tr> <td>SStP SR-SQ 444</td> <td>–</td> <td>○</td> <td>–</td> </tr> <tr> <td>SStP SR-SQ 422</td> <td>○</td> <td>–</td> <td>–</td> </tr> <tr> <td>SStP SR-Lite 422</td> <td>○</td> <td>–</td> <td>–</td> </tr> <tr> <td>DNxHD 220x HD P</td> <td>○</td> <td>–</td> <td>–</td> </tr> <tr> <td>DNxHD 145 HD P</td> <td>○</td> <td>–</td> <td>–</td> </tr> <tr> <td>ProRes 422 HQ HD P</td> <td>○</td> <td>–</td> <td>–</td> </tr> <tr> <td>ProRes 422 HD P</td> <td>○</td> <td>–</td> <td>–</td> </tr> </tbody> </table>	Recording format	Main Operation			YPbPr	RGB	RAW**	XAVC 4096 × 2160P	○	–	–	XAVC 3840 × 2160P	○	–	–	XAVC 2048 × 1080P	○	○	○	XAVC 1920 × 1080P	○	○	○	MPEG 1920 × 1080P	○	○	○	SStP SR-SQ 444	–	○	–	SStP SR-SQ 422	○	–	–	SStP SR-Lite 422	○	–	–	DNxHD 220x HD P	○	–	–	DNxHD 145 HD P	○	–	–	ProRes 422 HQ HD P	○	–	–	ProRes 422 HD P	○	–	–	
Recording format	Main Operation																																																								
	YPbPr	RGB	RAW**																																																						
XAVC 4096 × 2160P	○	–	–																																																						
XAVC 3840 × 2160P	○	–	–																																																						
XAVC 2048 × 1080P	○	○	○																																																						
XAVC 1920 × 1080P	○	○	○																																																						
MPEG 1920 × 1080P	○	○	○																																																						
SStP SR-SQ 444	–	○	–																																																						
SStP SR-SQ 422	○	–	–																																																						
SStP SR-Lite 422	○	–	–																																																						
DNxHD 220x HD P	○	–	–																																																						
DNxHD 145 HD P	○	–	–																																																						
ProRes 422 HQ HD P	○	–	–																																																						
ProRes 422 HD P	○	–	–																																																						
	When system frequency is set to 24																																																								
	<table border="1"> <thead> <tr> <th rowspan="2">Recording format</th> <th colspan="3">Main Operation</th> </tr> <tr> <th>YPbPr</th> <th>RGB</th> <th>RAW**</th> </tr> </thead> <tbody> <tr> <td>XAVC 4096 × 2160P</td> <td>○</td> <td>–</td> <td>–</td> </tr> <tr> <td>XAVC 2048 × 1080P</td> <td>○</td> <td>○</td> <td>○</td> </tr> <tr> <td>SStP SR-SQ 444</td> <td>–</td> <td>○</td> <td>–</td> </tr> <tr> <td>SStP SR-SQ 422</td> <td>○</td> <td>–</td> <td>–</td> </tr> <tr> <td>SStP SR-Lite 422</td> <td>○</td> <td>–</td> <td>–</td> </tr> <tr> <td>ProRes 422 HQ HD P</td> <td>○</td> <td>–</td> <td>–</td> </tr> <tr> <td>ProRes 422 HD P</td> <td>○</td> <td>–</td> <td>–</td> </tr> </tbody> </table>	Recording format	Main Operation			YPbPr	RGB	RAW**	XAVC 4096 × 2160P	○	–	–	XAVC 2048 × 1080P	○	○	○	SStP SR-SQ 444	–	○	–	SStP SR-SQ 422	○	–	–	SStP SR-Lite 422	○	–	–	ProRes 422 HQ HD P	○	–	–	ProRes 422 HD P	○	–	–																					
Recording format	Main Operation																																																								
	YPbPr	RGB	RAW**																																																						
XAVC 4096 × 2160P	○	–	–																																																						
XAVC 2048 × 1080P	○	○	○																																																						
SStP SR-SQ 444	–	○	–																																																						
SStP SR-SQ 422	○	–	–																																																						
SStP SR-Lite 422	○	–	–																																																						
ProRes 422 HQ HD P	○	–	–																																																						
ProRes 422 HD P	○	–	–																																																						
	** “Rec Control” of the Recording menu needs to be set to “SxS&AXS.”																																																								

System		
Menu items	Sub items and setting values	Contents
<b>Genlock</b> Setting Genlock operation	Reference <b>Internal</b> / External (HD) / External (SD)	Displays the genlock status. When genlocked, the signal type is displayed. Internal: Not genlocked. External (HD): Genlocked by the HD signal. External (SD): Genlocked by the SD signal.
<b>Assignable Button</b> Assigning functions to the assignable buttons	<1> to <4> (<5> to <8>), Lens RET <b>Off</b> / Marker / Zebra / Peaking / Display / Video Signal Monitor / VF Focus Magnifier / VF Mode / Rec / S&Q Motion / Picture Cache Rec / Rec Review / High/Low Key / White Memory / VF High Contrast / Color Bars	Assign a function to the ASSIGN 1/2/3/4 (5/6/7/8) buttons and RET button on the lens. Marker: Turns the center marker, safety zone, aspect marker, and guide frame functions on/off as a group. Zebra: Turns the zebra function on/off. Peaking: Turns the peaking function on/off. Display: Turns the indications of status/setting on the monitor on/off. Video Signal Monitor: Switches the waveform indication (Off/Waveform/Vector/Histogram) for the output signal from SDI (Sub). VF Focus Magnifier: Turn the Focus Magnifier function of the viewfinder on/off. VF Mode: Switches between color and mono display on the viewfinder. Rec: Executes the start/stop recording. (The lamp of the ASSIGN button lights up while recording.) S&Q Motion: Turns the Slow & Quick motion function on/off. Picture Cache Rec: Turn the Picture Cache Rec function on/off. Rec Review: Performs Rec Review. High/Low Key: Switches between High Key (monitoring display for high key blown-out highlights), Low Key (monitoring display for low key clipped blacks), and Off (normal display). White Memory: Switches between Memory A and Memory B of "White Switch." VF High Contrast: Enhances the contrast of the pictures on the viewfinder. Color Bars: Turn the color bar on/off.
		<b>Tip</b> When attaching the CBK-55BK, "ASSIGN 5 to 8" is displayed. "Color Bars" is assigned to ASSIGN 5 for the default setting.
	Menu Dial Assign <b>Off</b> / S&Q Frame Rate(Step)	Assign a function to the MENU dial. S&Q Frame Rate(Step): Selects the frame rate that is selected in "Frame Rate<1> to <6>" when "Setting" in "S&Q Motion" is set to "On."
	S&Q Frame Rate<1> to <6> 1FPS to 240FPS Default setting S&Q Frame Rate<1>: 24FPS S&Q Frame Rate<2>: 32FPS S&Q Frame Rate<3>: 48FPS S&Q Frame Rate<4>: 60FPS S&Q Frame Rate<5>: 90FPS S&Q Frame Rate<6>: 120FPS	Sets the frame rate that is selected in "S&Q Frame Rate(Step)." You can select from 1 to 60, 72, 75, 80, 90, 96, 100, 110, 120, 125, 135, 144, 150, 160, 168, 175, 180, and 240FPS.

System		
Menu items	Sub items and setting values	Contents
<b>Switch/Lamp</b> Setting for the switch/lamp	Rec Lamp <b>On / Off</b>	Turns the Rec lamp on/off.
	Lock Switch Setting <b>without Rec Button / with Rec Button</b>	Sets whether to include the Rec button on the buttons that are locked by the LOCK switch. (When the Rec function is assigned to the assignable button, the button is treated as the Rec button.)
	Menu Dial Scroll <b>Normal / Loop</b>	Selects the scroll method for the menu operation.
	Menu Dial Direction <b>Normal / Reverse</b>	Selects the scroll direction for the menu operation.
	Set Key on Thumbnail <b>Pause / Play</b>	Sets the behavior when pressing the MENU dial while selecting a thumbnail.
<b>Fan Control</b> Setting the fan control mode	Setting <b>Auto / Minimum / Off in Rec</b>	Sets the fan control mode of the camcorder and AXS recorder that is connected to the camcorder.
<b>Battery Alarm</b> Setting for the battery	Near End:Info Battery <b>5% to 100%</b> (in steps of 5%)	Sets the battery level at which the low battery warning is generated.
	End:Info Battery <b>0% to 5%</b>	Sets the battery level at which the battery empty warning is generated.
	Near End:Sony Battery <b>11.5V to 17V</b> (in steps of 0.1V)	Sets the battery level at which the low battery warning is generated.
	End:Sony Battery <b>11.0V to 11.5V</b> (in steps of 0.1V)	Sets the battery level at which the battery empty warning is generated.
	Near End:Other Battery 11.5V to 17V ( <b>11.8V</b> ) (in steps of 0.1V)	Sets the battery level at which the low battery warning is generated.
	End:Other Battery <b>11.0V to 14V</b> (in steps of 0.1V)	Sets the battery level at which the battery empty warning is generated.
	Detected Battery Sony Info Battery / Sony Battery / Other Battery / DC IN	Displays the type of power supply.
<b>DC Voltage Alarm</b> Setting the warning of the input voltage	DC Low Voltage1 <b>11.5V to 17.0V</b>	Sets the DC IN voltage at which the low input voltage warning is generated.
	DC Low Voltage2 <b>11.0V to 14.0V</b>	Sets the DC IN voltage at which the lack of any input voltage warning is generated.
<b>Language</b> Selecting the language for menus and messages	Select English / 中文 (简)	Selects the language for menus and messages.

System		
Menu items	Sub items and setting values	Contents
<b>Clock Set</b> Setting the built-in clock	Time Zone UTC -12:00 Kwajalein to UTC +14:00	Sets the time-zone difference from UTC in steps of 30 minutes.
	Date Mode <b>YYMMDD</b> / MMDDYY / DDDMMYY	Selects the display mode of the date. YYMMDD: In sequence of year, month, day MMDDYY: In sequence of month, day, year DDMMYY: In sequence of day, month, year
	12H/24H 12H / <b>24H</b>	Selects the display mode of time. 12H: 12-hour mode 24H: 24-hour mode
	Date	Sets the current date. SET: Sets the date.
	Time	Sets the current time. SET: Sets the time.
	<b>Hours Meter</b> Displaying the hours meter	Hours(System)
Hours(Reset)		Displays the resettable accumulated time of use.
Reset Execute / Cancel		Resets the "Hours(Reset)" value to 0. Execute: Execute resetting.
<b>AXS Recorder</b> Setting for the AXS recorder	Chunk <b>Off</b> / 16GB / 8GB / 4GB	This setting is for dividing the clip to the specified size while recording on the AXS memory card.
	Version	Displays the software version of AXS-R5.
	Hours Meter (System)	Displays the non-resettable accumulated time of use for AXS-R5.
<b>Note</b> This item cannot be selected when the AXS recorder (AXS-R5) is not attached.	Hours Meter (Reset)	Displays the resettable accumulated time of use for AXS-R5.
	Reset Hours Meter Execute / Cancel	Resets the "Hours Meter (Reset)" value to 0. Execute: Executes resetting.
	<b>Basic Authentication</b>	
Setting for the basic authentication of the network	User Name <b>(admin)</b>	Set a desired user name in 1 to 31 alphanumeric characters.
	Password <b>(pmw-f5 or pmw-f55)</b>	Sets a password in 1 to 31 alphanumeric characters.
<b>Wi-Fi</b> Setting for Wi-Fi connection	Wi-Fi Enable / <b>Disable</b>	Select whether to enable or disable Wi-Fi connection.
	SSID & Password	Displays the SSID and password of the camcorder.
	Wi-Fi Direct Connection Execute / Cancel	Starts connecting process by the Wi-Fi Direct function. Execute: Executing.
	Client	Displays the status of the connected client device (device name or Mac address).
	IP Address 10.0.0.1	Displays the IP address.
	Subnet Mask 255.255.0.0	Displays the subnet mask.
	MAC Address	Display the MAC address.
	Regenerate Password Execute / Cancel	Regenerates the password. Execute: Executing.

System		
Menu items	Sub items and setting values	Contents
<b>All Reset</b> Resetting to the factory status	Reset	Resets the camcorder to the factory status.
	Execute/Cancel	Execute: Executes resetting.
<b>Option</b> Settings and display of the option	DNxHD/ProRes ○ / ×	When the expansion codec board CBK-55PD (optional) is attached, “○” is displayed.
	4K/QFHD XAVC ○ / ×	When the 4K upgrade license CBKZ-55PX for the PMW-F5 (optional) is installed, “○” is displayed.
	Install Option	Select when installing the upgrade license.
	ID	Displays the camcorder-specific ID that is set when the license key is acquired.
<b>Version</b> Showing the version of this camcorder	Number Vx.xx	Displays the current software version of the camcorder.
	Version Up Execute / Cancel	Upgrades the camcorder. Execute: Executes.

# Connecting External Monitors and Recording Devices

To display recording/playback pictures on an external monitor, select the output signal and use an appropriate cable for the monitor to be connected.

An output signal from the camcorder can be recorded when a recording device is connected. The same status information and menus can be displayed on the external monitor as those on the viewfinder screen.

According to the signal fed to the monitor, set "Output Display" (page 79) in the Video menu to "On."

## SDI OUT connector (BNC type)

Set the on/off setting of the output, and output format in the Video menu (page 77).

Use a commercially available 75-ohm coaxial cable for connection.

**Note**

Be sure to ground between the camcorder and external device before turning the power on. (We recommend to turn on the camcorder and external device after connecting a 75-ohm coaxial cable.)

When connecting an external device to the camcorder while the camcorder is turned on, connect the external device after connecting a 75-ohm coaxial cable to the external device.

### To start synchronized recording on an external device

With SDI signal output selected, synchronized recording is possible by feeding a REC trigger signal to an external recording device connected via the SDI OUT connector. To enable synchronized recording, set "SDI Rec Control" (page 84) in the Recording menu to "On."

**Note**

When a connected external device does not correspond to a REC trigger signal, the device cannot be operated.

## HDMI OUT connector (Type A connector)

Set the on/off setting of the output, and output format in the Video menu (page 77).

Use a commercially available HDMI cable for connection.

## TEST OUT connector (BNC type)

Use a commercially available BNC cable for connection.

## DC OUT connector (4-pin)

Supplies DC 12 V power to an accessory when the power switch is set to ON.

You can output the REC Tally signal and input the REC Trigger signal through the DC OUT connector.

4-pin, Female

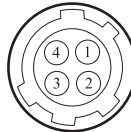

- External View -

No.	Signal	I/O	Specification
1	UNREG GND	-	GND for UNREG
2	REC TALLY	OUT	Open Collector output (Max. 50 mA) Low: REC
3	REC TRIGGER	IN	Open or +5 V dc: Normal GND: Active (REC)
4	UNREG +12 V OUT	OUT	+11 V to 17 V dc output



# Operating Clips With a Computer

## To use the ExpressCard slot of a computer

If the computer is equipped with an ExpressCard/34 or ExpressCard/54 slot, you can directly insert the SxS memory card containing clips recorded with this camcorder and access the files.

### Notes

- The SxS Device Driver Software must be installed on your computer.
- Operation is not guaranteed with all computers.

*For support information for the driver, visit the following URL:*

<http://www.sony.net/SxS-Support/>

With a Windows computer, check that a Removable Disk appears in My Computer. This indicates normal status.

With a Macintosh computer, an icon is displayed on the menu bar.

## To connect with a USB cable

When you connect the camcorder or the SBAC-US20 SxS Memory Card USB Reader/Writer (optional) using a USB cable, the memory card in the slot is acknowledged as an extended drive by the computer.

When two memory cards are mounted in this camcorder, they are acknowledged as two independent extended drives by the computer.

### Note

The camcorder does not work on the bus power from the computer. Supply the operating power.

## To check the connection to the camcorder

### 1 Set the power switch to ON to turn on the camcorder.

A message prompting you to confirm that you wish to enable the USB connection is displayed on the viewfinder screen.

### Note

This message will not be displayed while another confirmation message or in-progress message (e.g., for formatting or restoring of an SxS memory card) is shown on the screen. It appears when formatting or restoration has completed. The USB connection is disabled while recording, playing, or displaying thumbnail.

### 2 Select “Execute” by turning the MENU dial.

### 3 With Windows, check that the memory card is displayed as a removable disk in My Computer.

**With Macintosh, check that a “NO NAME” or “Untitled” folder was created on the desktop. (The Macintosh folder name can be changed.)**

### Notes

- The following operations must be avoided when the ACCESS lamp is lit in red.
  - Turning the power off or disconnecting the power cord
  - Removing the SxS memory card
  - Disconnecting the USB cable
- When removing an SxS memory card from a Macintosh, do not select “Card Power Off” from the SxS memory card icon displayed on the menu bar.
- Operation is not guaranteed with all computers.

## Using a nonlinear editing system

For a nonlinear editing system, optional editing software that corresponds to the recording formats used with this camcorder is required.

Store the clips to be edited on the HDD of your computer in advance, using the dedicated application software.

# External Synchronization

When multiple units of the camcorder are used in the same shooting location, synchronized recording can be made with a specific reference signal, and the timecode can be matched among all the units.

## Aligning the phase of the video signal (Genlock)

Genlock operation is enabled by supplying a reference signal to the GENLOCK IN connector (page 16) of the camcorder.

Valid reference signals depend on the system frequency setting.

System frequency	Valid reference signal
59.94P	1920 × 1080 59.94i 720 × 486 59.94i
59.94i	1920 × 1080 59.94i 720 × 486 59.94i
50P	1920 × 1080 50i 720 × 576 50i
50i	1920 × 1080 50i 720 × 576 50i
29.97P	1920 × 1080 59.94i 720 × 486 59.94i
25P	1920 × 1080 50i 720 × 576 50i
24P	1920 × 1080 48i (24PsF)
23.98P	1920 × 1080 47.95i (23.98PsF)

You can check the genlock status on “Reference” in “Genlock” (page 92) of the System menu.

### Notes

- If the reference signal is unstable, genlock is not possible.
- The subcarrier is not synchronized.

## Synchronizing the timecode of your camcorder with that of another unit

Set the unit that supplies the timecode to a mode in which the timecode output keeps advancing (Free Run mode).

### 1 Set “Timecode” in the TC/UB menu as follows:

Mode: Preset (Ext-Lk)

Run: Free Run

### 2 Confirm that the TC IN/OUT switch (page 16) is set to IN, then supply an HD or SD reference video signal to the GENLOCK IN connector (page 16) and the reference timecode to the TC connector (page 16).

The built-in timecode generator of your camcorder locks to the reference timecode, and the message “Ext-Lk” is displayed on the screen. About 10 seconds after locking, even if the reference timecode from the external device is disconnected, the external lock will be kept.

### Notes

- Check that the reference timecode and the reference video signal are in a phase relation that complies with the SMPTE timecode standards.
- When you finish the above procedure, the timecode is immediately synchronized with the external timecode, and the time data indication will show the value of the external timecode. However, wait for a few seconds until the timecode generator stabilizes before recording.
- If the frequency of the reference video signal and the frame frequency are not the same, a lock cannot be acquired, and the camcorder will not operate properly. In such a case, the timecode will not be correctly locked to the external timecode.
- When the connection is removed, the timecode advance may shift one frame per hour with respect to the reference timecode.

### To release the external timecode synchronization

Change the “Timecode” setting in the TC/UB menu.

External synchronization is also released when you start recording in a special recording mode.

## Important Notes on Operation

---

### Use and Storage

---

#### Do not subject the unit to severe shock

The internal mechanism may be damaged or the body warped.

#### Do not cover the unit while operating

Putting a cloth, for example, over the unit can cause excessive internal heat build-up.

#### After use

Always set the power switch to OFF.

#### Before storing the unit for a long period

Remove the battery pack.

#### Do not leave the camcorder with the lenses facing the sun

Direct sunlight can enter through the lenses, be focused in the camcorder, and cause fire.

---

### Shipping

---

- Remove the memory cards before transporting the unit.
- If sending the unit by truck, ship, air or other transportation service, pack it in the shipping carton of the unit.

---

### Care of the unit

---

If the body of the unit is dirty, clean it with a soft, dry cloth. In extreme cases, use a cloth steeped in a little neutral detergent, then wipe dry. Do not use organic solvents such as alcohol or thinner, as these may cause discoloration or other damage to the finish of the unit.

#### In the event of operating problems

If you should experience problems with the unit, contact your Sony dealer.

---

### Note about the battery terminal

---

The battery terminal of this unit (the connector for battery packs and AC adaptors) is a consumable part.

Power may not be supplied to the unit properly if the pins of the battery terminal are bent or deformed by shock or vibrations, or if they become corroded due to prolonged outdoor use.

Periodic inspections are recommended to keep the unit working properly and to prolong its usable lifetime.

Contact a Sony service or sales representative for more information about inspections.

---

### Use and storage locations

---

Store in a level, ventilated place. Avoid using or storing the unit in the following places:

- In excessive heat or cold (operating temperature range: 0°C to 40°C or 32°F to 104°F)  
Remember that in summer in warm climates the temperature inside a car with the windows closed can easily exceed 50°C (122°F).
- In damp or dusty locations
- Locations where the unit may be exposed to rain
- Locations subject to violent vibration
- Near strong magnetic fields
- Close to radio or TV transmitters producing strong electromagnetic fields.
- In direct sunlight or close to heaters for extended periods

#### To prevent electromagnetic interference from portable communications devices

The use of portable telephones and other communications devices near this unit can result in malfunctions and interference with audio and video signals.

It is recommended that the portable communications devices near this unit be powered off.

#### Note on laser beams

Laser beams may damage the CMOS image sensors. If you shoot a scene that includes a laser beam, be careful not to let the laser beam be directed into the lens of the camcorder.

---

## About the LCD monitor

---

- Do not leave the LCD monitor facing direct sunlight, as this may damage the LCD monitor.
- Do not press/swipe the LCD monitor forcefully, or leave objects on the LCD monitor, as it may cause a malfunction, such as picture irregularity, etc.
- The LCD monitor may become warm in use. This is not a malfunction.

---

## About the stuck pixels

---

The LCD panel fitted to this unit is manufactured with high precision technology, giving a functioning pixel ratio of at least 99.99%. Thus a very small proportion of pixels may be “stuck”, either always off (black), always on (red, green, or blue), or flashing. In addition, over a long period of use, because of the physical characteristics of the liquid crystal display, such “stuck” pixels may appear spontaneously. These problems are not a malfunction, and will not be recorded on recording media.

---

## Phenomena specific to CMOS image sensors

---

The following phenomena that may appear in images are specific to CMOS (Complementary Metal Oxide Semiconductor) image sensors. They do not indicate malfunctions.

### White flecks

Although the CMOS image sensors are produced with high-precision technologies, fine white flecks may be generated on the screen in rare cases, caused by cosmic rays, etc. This is related to the principle of CMOS image sensors and is not a malfunction.

The white flecks especially tend to be seen in the following cases:

- when operating at a high environmental temperature
- when you have raised the master gain (sensitivity)
- when operating in Slow-Shutter mode

### Aliasing

When fine patterns, stripes, or lines are shot, they may appear jagged or flicker.

## Focal plane (PMW-F5 only)

Owing to the characteristics of the pickup elements (CMOS sensors) for reading video signals, subjects that quickly move across the screen may appear slightly skewed.

## Flash band (PMW-F5 only)

The luminance at the top and bottom of the screen may change when shooting a flashlight beam or a light source that quickly flashes.

## Flicker (PMW-F5 only)

Shooting under the lights of a discharge lamp such as a fluorescent lamp, sodium-vapor lamp, mercury-vapor lamp, etc., may cause flickering, color change, or vertical stripes.

---

## Note on the display

---

- Pictures on the viewfinder screen may be distorted by the following operations:
  - Changing the video format
  - Starting playback from the Thumbnail screen
- When you change the eye direction in the viewfinder, you may see primary colors red, green, and blue, but this is not a defect of the camcorder. These primary colors are not recorded on any recording media.

---

## Fragmentation

---

If pictures cannot be recorded/reproduced properly, try formatting the recording medium. While repeating picture recording/playback with a certain recording medium for an extended period, files in the medium may be fragmented, disabling proper recording/storage. In such a case, make a backup of clips in the medium then perform formatting of the medium using “Format Media” (*page 85*) in the Media menu.

# Formats and Limitations of Outputs

## Video Formats and Output Signals

### Tip

When using the 1.3× or 2× anamorphic lens, set “Aspect” in “VF Setting” (page 80) of the VF menu to “Anamo ×1.3” or “Anamo ×2” to output the normal image without distortion from the SDI OUT (Sub), HDMI OUT, and TEST OUT connectors.

### Output formats for the SDI OUT connector

Serial digital signals from the SDI OUT connector are output depending on the settings of the setup menu and format of the clip being played.

**When outputting one type of SDI output by using the SDI OUT 1 to 4 connectors while “Main Operation” in “Base Setting” is set to “YPbPr” (PMW-F55 and PMW-F5 + CBKZ-55FX only)**

The “Frequency” setting in “System Setting” of the System menu	The “Format” setting in “Rec format” of the System menu	Output format		
		SDI (Main)		
59.94/50	XAVC 4096 × 2160P	4096 × 2160 YPbPr Square Division 59.94P/50P 3.0G		
		4096 × 2160 YPbPr 2-Sample Interleave Division 59.94P/50P 3.0G		
		3840 × 2160 YPbPr Square Division 59.94P/50P 3.0G		
		3840 × 2160 YPbPr 2-Sample Interleave Division 59.94P/50P 3.0G		
	XAVC 3840 × 2160P	3840 × 2160 YPbPr Square Division 59.94P/50P 3.0G		
		3840 × 2160 YPbPr 2-Sample Interleave Division 59.94P/50P 3.0G		
		29.97/25/23.98	XAVC 4096 × 2160P	4096 × 2160 YPbPr Square Division 29.97P/25P/23.98P 1.5G
				4096 × 2160 YPbPr 2-Sample Interleave Division 29.97P/25P/23.98P 3.0G (SDI 1/2 only)
3840 × 2160 YPbPr Square Division 29.97P/25P/23.98P 1.5G				
3840 × 2160 YPbPr 2-Sample Interleave Division 29.97P/25P/23.98P 3.0G (SDI 1/2 only)				
XAVC 3840 × 2160P	3840 × 2160 YPbPr Square Division 29.97P/25P/23.98P 1.5G			
	3840 × 2160 YPbPr 2-Sample Interleave Division 29.97P/25P/23.98P 3.0G (SDI 1/2 only)			
	24		XAVC 4096 × 2160P	4096 × 2160 YPbPr Square Division 24P 1.5G
				4096 × 2160 YPbPr 2-Sample Interleave Division 24P 3.0G (SDI 1/2 only)
3840 × 2160 YPbPr Square Division 24P 1.5G				
3840 × 2160 YPbPr 2-Sample Interleave Division 24P 3.0G (SDI 1/2 only)				

**When outputting two types of SDI output by using the SDI OUT 1/2 (MAIN) and SDI OUT 3/4 (SUB) connectors while “Main Operation” in “Base Setting” is set to “YPbPr”**

The “Frequency” setting in “System Setting” of the System menu	The “Format” setting in “Rec format” of the System menu	Output format		
		SDI (Main)	SDI (Sub)	
59.94/50	XAVC 4096 × 2160P (PMW-F55 and PMW-F5 + CBKZ-55FX only)	2048 × 1080 YPbPr 59.94P/50P 3.0G	1920 × 1080 YPbPr 59.94P/50P 3.0G 1920 × 1080 YPbPr 59.94i/50i 1.5G	
		1920 × 1080 YPbPr 59.94P/50P 3.0G	1920 × 1080 YPbPr 59.94P/50P 3.0G 1920 × 1080 YPbPr 59.94i/50i 1.5G	
		1920 × 1080 YPbPr 59.94i/50i 1.5G	1920 × 1080 YPbPr 59.94i/50i 1.5G	
	XAVC 3840 × 2160P (PMW-F55 and PMW-F5 + CBKZ-55FX only)	1920 × 1080 YPbPr 59.94P/50P 3.0G	1920 × 1080 YPbPr 59.94P/50P 3.0G 1920 × 1080 YPbPr 59.94i/50i 1.5G	
		1920 × 1080 YPbPr 59.94i/50i 1.5G	1920 × 1080 YPbPr 59.94i/50i 1.5G	
		XAVC 2048 × 1080P	2048 × 1080 YPbPr 59.94P/50P 3.0G	1920 × 1080 YPbPr 59.94P/50P 3.0G 1920 × 1080 YPbPr 59.94i/50i 1.5G 720 × 486/576 YPbPr 59.94i/50i 270M*
		1920 × 1080 YPbPr 59.94P/50P 3.0G	1920 × 1080 YPbPr 59.94P/50P 3.0G	1920 × 1080 YPbPr 59.94P/50P 3.0G 1920 × 1080 YPbPr 59.94i/50i 1.5G 720 × 486/576 YPbPr 59.94i/50i 270M*
			1920 × 1080 YPbPr 59.94i/50i 1.5G	1920 × 1080 YPbPr 59.94i/50i 1.5G 720 × 486/576 YPbPr 59.94i/50i 270M*
			1920 × 1080 YPbPr 59.94i/50i 1.5G	1920 × 1080 YPbPr 59.94i/50i 1.5G 720 × 486/576 YPbPr 59.94i/50i 270M*
	XAVC 1920 × 1080P MPEG 1920 × 1080i	1920 × 1080 YPbPr 59.94P/50P 3.0G	1920 × 1080 YPbPr 59.94P/50P 3.0G	1920 × 1080 YPbPr 59.94P/50P 3.0G 1920 × 1080 YPbPr 59.94i/50i 1.5G 720 × 486/576 YPbPr 59.94i/50i 270M*
			1920 × 1080 YPbPr 59.94i/50i 1.5G	1920 × 1080 YPbPr 59.94i/50i 1.5G 720 × 486/576 YPbPr 59.94i/50i 270M*
			MPEG 1280 × 720P	1280 × 720 YPbPr 59.94P/50P 1.5G

The “Frequency” setting in “System Setting” of the System menu	The “Format” setting in “Rec format” of the System menu	Output format	
		SDI (Main)	SDI (Sub)
	SSiP SR-SQ 422	1920 × 1080 YPbPr 59.94i/50i 1.5G	1920 × 1080 YPbPr 59.94i/50i 1.5G 720 × 486/576 YPbPr 59.94i/50i 270M*
	DNxHD 220x HD i DNxHD 145 HD i ProRes 422 HQ HD i ProRes 422 HD i (When the CBK-55PD is installed)	1920 × 1080 YPbPr 59.94i/50i 1.5G	1920 × 1080 YPbPr 59.94i/50i 1.5G
29.97/25	XAVC 4096 × 2160P (PMW-F55 and PMW-F5 + CBKZ-55FX only)	2048 × 1080 YPbPr 29.97PsF/25PsF 1.5G	1920 × 1080 YPbPr 29.97PsF/25PsF 1.5G
		1920 × 1080 YPbPr 29.97PsF/25PsF 1.5G	
	XAVC 3840 × 2160P (PMW-F55 and PMW-F5 + CBKZ-55FX only)	1920 × 1080 YPbPr 29.97PsF/25PsF 1.5G	1920 × 1080 YPbPr 29.97PsF/25PsF 1.5G
		XAVC 2048 × 1080P	2048 × 1080 YPbPr 29.97PsF/25PsF 1.5G
	1920 × 1080 YPbPr 29.97PsF/25PsF 1.5G		1920 × 1080 YPbPr 29.97PsF/25PsF 1.5G
			720 × 486/576 YPbPr 29.97PsF/25PsF 270M
	XAVC 1920 × 1080P MPEG 1920 × 1080i SSiP SR-SQ/Lite 422	1920 × 1080 YPbPr 29.97PsF/25PsF 1.5G	1920 × 1080 YPbPr 29.97PsF/25PsF 1.5G 720 × 486/576 YPbPr 29.97PsF/25PsF 270M
DNxHD 220x HD P DNxHD 145 HD P ProRes 422 HQ HD P ProRes 422 HD P (When the CBK-55PD is installed)	1920 × 1080 YPbPr 29.97P/25P 1.5G	1920 × 1080 YPbPr 29.97PsF/25PsF 1.5G	
24	XAVC 4096 × 2160P (PMW-F55 and PMW-F5 + CBKZ-55FX only) XAVC 2048 × 1080P	2048 × 1080 YPbPr 24PsF 1.5G	1920 × 1080 YPbPr 24PsF 1.5G
		1920 × 1080 YPbPr 24PsF 1.5G	
	SSiP SR-SQ/Lite 422	1920 × 1080 YPbPr 24PsF 1.5G	1920 × 1080 YPbPr 24PsF 1.5G
	ProRes 422 HQ HD P ProRes 422 HD P (When the CBK-55PD is installed)	1920 × 1080 YPbPr 24P 1.5G	1920 × 1080 YPbPr 24PsF 1.5G

The “Frequency” setting in “System Setting” of the System menu	The “Format” setting in “Rec format” of the System menu	Output format	
		SDI (Main)	SDI (Sub)
23.98	XAVC 4096 × 2160P (PMW-F55 and PMW-F5 + CBKZ-55FX only)	2048 × 1080 YPbPr 23.98PsF 1.5G	1920 × 1080 YPbPr 23.98PsF 1.5G
	XAVC 2048 × 1080P	1920 × 1080 YPbPr 23.98PsF 1.5G	
	XAVC 3840 × 2160P (PMW-F55 and PMW-F5 + CBKZ-55FX only)	1920 × 1080 YPbPr 23.98PsF 1.5G	1920 × 1080 YPbPr 23.98PsF 1.5G
	XAVC 1920 × 1080P MPEG 1920 × 1080i SSiP SR-SQ/Lite 422	1920 × 1080 YPbPr 23.98PsF 1.5G	1920 × 1080 YPbPr 23.98PsF 1.5G
	DNxHD 220x HD P DNxHD 145 HD P ProRes 422 HQ HD P ProRes 422 HD P (When the CBK-55PD is installed)	1920 × 1080 YPbPr 23.98P 1.5G	1920 × 1080 YPbPr 23.98PsF 1.5G

\* Cannot be selected when “Shooting Mode” in “Base Setting” of the System menu is set to “Cine EI.”

**When outputting two types of SDI output by using the SDI OUT 1/2 (MAIN) and SDI OUT 3/4 (SUB) connectors while “Main Operation” in “Base Setting” is set to “RGB”**

The “Frequency” setting in “System Setting” of the System menu	The “Format” setting in “Rec format” of the System menu	Output format	
		SDI (Main)	SDI (Sub)
59.94/50	XAVC 2048 × 1080P	2048 × 1080 RGB 59.94P/50P 3.0G	1920 × 1080 YPbPr 59.94P/50P 3.0G
			1920 × 1080 YPbPr 59.94i/50i 1.5G
		1920 × 1080 RGB 59.94P/50P 3.0G	1920 × 1080 YPbPr 59.94i/50i 1.5G
	XAVC 1920 × 1080P MPEG 1920 × 1080i	1920 × 1080 RGB 59.94P/50P 3.0G	1920 × 1080 YPbPr 59.94P/50P 3.0G
			1920 × 1080 YPbPr 59.94i/50i 1.5G
29.97/25	XAVC 2048 × 1080P	2048 × 1080 RGB 29.97PsF/25PsF 3.0G	1920 × 1080 YPbPr 29.97PsF/25PsF 1.5G
			1920 × 1080 YPbPr 29.97PsF/25PsF 1.5G
		1920 × 1080 RGB 29.97PsF/25PsF 3.0G	1920 × 1080 YPbPr 29.97PsF/25PsF 1.5G
	XAVC 1920 × 1080P MPEG 1920 × 1080i SSiP SR-SQ444	1920 × 1080 RGB 29.97PsF/25PsF 3.0G	1920 × 1080 YPbPr 29.97PsF/25PsF 1.5G
			1920 × 1080 YPbPr 29.97PsF/25PsF 1.5G
24	XAVC 2048 × 1080P	2048 × 1080 RGB 24PsF 3.0G	1920 × 1080 YPbPr 24PsF 1.5G
		1920 × 1080 RGB 24PsF 3.0G	
	SSiP SR-SQ444	1920 × 1080 RGB 24PsF 3.0G	1920 × 1080 YPbPr 24PsF 1.5G



The “Frequency” setting in “System Setting” of the System menu	The “Format” setting in “Rec format” of the System menu	Output format	
		SDI (Main)	SDI (Sub)
23.98	XAVC 2048 × 1080P	2048 × 1080 RGB	1920 × 1080 YPbPr 23.98PsF 1.5G
		23.98PsF 3.0G	
	XAVC 1920 × 1080P MPEG 1920 × 1080i SSiP SR-SQ444	1920 × 1080 RGB	1920 × 1080 YPbPr 23.98PsF 1.5G
		23.98PsF 3.0G	

## Output formats from the HDMI OUT connector

Serial digital signals from the HDMI OUT connector are output depending on the settings of the setup menu and format of the clip being played.

**When the output format of SDI (MAIN) is 4096 × 2160P or 3480 × 2160P (PMW-F55 and PMW-F5 + CBKZ-55FX only)**

The “Frequency” setting in “System Setting” of the System menu	The “SDI (Main)” setting in “Output Format” of the Video menu	Output format
59.94/50	4096 × 2160P Square 3840 × 2160P Square	1920 × 1080 59.94P/50P
		1920 × 1080 59.94i/50i
	4096 × 2160P 2SI	4096 × 2160 59.94P/50P
		1920 × 1080 59.94P/50P
		1920 × 1080 59.94i/50i
	3840 × 2160P 2SI	3840 × 2160 59.94P/50P
		1920 × 1080 59.94P/50P
		1920 × 1080 59.94i/50i
29.97/25	4096 × 2160P Square 3840 × 2160P Square	1920 × 1080 29.97PsF/25PsF
	4096 × 2160P 2SI	4096 × 2160 29.97P/25P
		1920 × 1080 29.97PsF/25PsF
	3840 × 2160P 2SI	3840 × 2160 29.97P/25P
		1920 × 1080 29.97PsF/25PsF
24/23.98	4096 × 2160P Square 3840 × 2160P Square	1920 × 1080 24P/23.98P
	4096 × 2160P 2SI	4096 × 2160 24P/23.98P
		1920 × 1080 24P/23.98P
	3840 × 2160P 2SI	3840 × 2160 24P/23.98P
		1920 × 1080 24P/23.98P

**When the output format of SDI (MAIN) is less than 2048 × 1080**

The “Frequency” setting in “System Setting” of the System menu	The “Format” setting in “Rec format” of the System menu	Output format		
59.94/50	XAVC 4096 × 2160P (PMW-F55 and PMW-F5 + CBKZ-55FX only) XAVC 3840 × 2160P (PMW-F55 and PMW-F5 + CBKZ-55FX only)	1920 × 1080 59.94P/50P 1920 × 1080 59.94i/50i		
	XAVC 2048 × 1080P XAVC 1920 × 1080P MPEG 1920 × 1080i	1920 × 1080 59.94P/50P 1920 × 1080 59.94i/50i 720 × 480/576 59.94P/50P		
	MPEG 1280 × 720P	1280 × 720 59.94P/50P 720 × 480/576 59.94P/50P		
	SStP SR-SQ 422	1920 × 1080 59.94i/50i 720 × 480/576 59.94P/50P		
	DNxHD 220x HD i DNxHD 145 HD i ProRes 422 HQ HD i ProRes 422 HD i	1920 × 1080 59.94i/50i		
	29.97/25	XAVC 4096 × 2160P (PMW-F55 and PMW-F5 + CBKZ-55FX only) XAVC 3840 × 2160P (PMW-F55 and PMW-F5 + CBKZ-55FX only) XAVC 2048 × 1080P XAVC 1920 × 1080P MPEG 1920 × 1080P	1920 × 1080 29.97PsF/25PsF	
		SStP SR-SQ 422		
		SStP SR-Lite 422		
		SStP SR-SQ 444		
		DNxHD 220x HD i DNxHD 145 HD i ProRes 422 HQ HD i ProRes 422 HD i		
24		XAVC 4096 × 2160P (PMW-F55 and PMW-F5 + CBKZ-55FX only) XAVC 2048 × 1080P		1920 × 1080 24P
		SStP SR-SQ 422		
		SStP SR-Lite 422		
		SStP SR-SQ 444		
		ProRes 422 HQ HD P		
	ProRes 422 HD P			

The “Frequency” setting in “System Setting” of the System menu	The “Format” setting in “Rec format” of the System menu	Output format
23.98	XAVC 4096 × 2160P (PMW-F55 and PMW-F5 + CBKZ-55FX only) XAVC 3840 × 2160P (PMW-F55 and PMW-F5 + CBKZ-55FX only) XAVC 2048 × 1080P XAVC 1920 × 1080P MPEG 1920 × 1080P SStP SR-SQ 422 SStP SR-Lite 422 SStP SR-SQ 444 DNxHD 220x HD P DNxHD 145 HD P ProRes 422 HQ HD P ProRes 422 HD P	1920 × 1080 23.98P

## Output formats from the TEST OUT connector

Signals output from the TEST OUT connector are either the HD-Y, Composite, or HD SYNC signals output from the SDI OUT connector/HDMI OUT connector.

The output signal differs depending on the setting of setup menu or output format setting of SDI (Main)/SDI (Sub).

The "Frequency" setting in "System Setting" of the System menu	Output format of SDI (Main)	Output format of SDI (Sub)	Output format
59.94/50	4096 × 2160 59.94P/50P (PMW-F55 and PMW-F5 + CBKZ-55FX only) 3840 × 2160 59.94P/50P (PMW-F55 and PMW-F5 + CBKZ-55FX only)	×	HD SYNC 1920 × 1080 59.94i/50i
	2048 × 1080 59.94P/50P 1920 × 1080 59.94P/50P 1920 × 1080 59.94i/50i	1920 × 1080 59.94P/50P	HD SYNC 1920 × 1080 59.94i/50i
		1920 × 1080 59.94i/50i	HD Y 1920 × 1080 59.94i/50i
		720 × 486/576 59.94i/50i	Composite 720 × 486/576 59.94i/50i
29.97/25	4096 × 2160 29.97P/25P (PMW-F55 and PMW-F5 + CBKZ-55FX only) 3840 × 2160 29.97P/25P (PMW-F55 and PMW-F5 + CBKZ-55FX only)	×	HD SYNC 1920 × 1080 29.97PsF/ 25PsF
	2048 × 1080 29.97PsF/ 25PsF 1920 × 1080 29.97PsF/ 25PsF	1920 × 1080 29.97PsF/ 25PsF	HD Y 1920 × 1080 29.97PsF/ 25PsF
		720 × 486/576 29.97PsF/ 25PsF	Composite 720 × 486/576 29.97PsF/ 25PsF
		×	HD SYNC 1920 × 1080 24PsF
24	4096 × 2160 24P (PMW-F55 and PMW-F5 + CBKZ-55FX only)	×	HD SYNC 1920 × 1080 24PsF
	2048 × 1080 24PsF 1920 × 1080 24PsF	1920 × 1080 24PsF	HD Y 1920 × 1080 24PsF
23.98	4096 × 2160 23.98P (PMW-F55 and PMW-F5 + CBKZ-55FX only) 3840 × 2160 23.98P (PMW-F55 and PMW-F5 + CBKZ-55FX only)	×	HD SYNC 1920 × 1080 23.98PsF
	2048 × 1080 23.98PsF 1920 × 1080 23.98PsF	1920 × 1080 23.98PsF	HD Y 1920 × 1080 23.98PsF

## Error/Warning Indications

The camcorder informs you of situations where warning, caution, or an operation check is required, through messages on the viewfinder screen, the REC lamp, and a buzzer.

The buzzer is output to the built-in speaker or to the headphones connected via the headphone connector. When the camcorder is turned on, the message for prompting the APR function appears on the viewfinder screen if the auto adjustment for the image sensor (APR) has not performed for a period of time. In this case, perform "APR" (page 89) by following the displayed message.

### Error Indications

The camcorder stops operation after the following indications.

Error indication on LCD/viewfinder	Buzzer	REC lamp	Cause and measures
E + Error code	Continuous	Rapidly flashing	The camcorder may be defective. Recording stops even if ●REC is displayed on the viewfinder screen. Turn off the power and check the connected equipment, cables, and media. If they are not defective, turn on the power again. If the error persists, consult Sony service personnel. (If power cannot be turned off by setting the power switch to OFF, remove both the battery pack or the DC IN source.)

### Warning Indications

When one of the following indications is generated, follow the message to resolve the problem.

Warning indication on LCD/viewfinder	Buzzer	REC lamp	Cause and measures
Media Near Full	Intermittent	Flashing	Free space on the SxS memory card has become insufficient. Replace it with another at the earliest opportunity.
Media Full	Continuous	Rapidly flashing	No space is left on the SxS memory card. Recording, clip copying and clip division cannot be performed. Replace it with another.
Battery Near End	Intermittent	Flashing	The battery power will be discharged soon. Charge the battery pack at the earliest opportunity.
Battery End	Continuous	Rapidly flashing	The battery pack is discharged. Recording cannot be performed. Stop operation and change the battery pack.
Temperature High	Intermittent	Flashing	The internal temperature has risen above a safe operation limit. Suspend operation, turn off the power, and wait until the temperature falls.
Voltage Low	Intermittent	Flashing	The DC IN voltage has become low (stage 1). Check the power supply.
Insufficient Voltage	Continuous	Rapidly flashing	The DC IN voltage is too low (stage 2). Recording cannot be performed. Connect another power source.
EXT. I/F Signal Error	–	–	An error was detected with the signal in the mounting terminal for an expansion unit. Check the connection to the AXS-R5, etc.

## Caution and Operation Confirmation Indications

The following caution and operation confirmation indication may be displayed on the center area of the screen. In this case, please see the following table.

Indication	Cause and measures
Battery Error	An error was detected with the battery pack.
Please Change Battery	Replace the battery pack with a normal one.
Backup Battery End	The remaining power of the backup battery is insufficient.
Please Change	Replace the battery pack.
Unknown Media(A)*	A partitioned memory card or one that contains recorded clips exceeding the number permitted with this camcorder is loaded.
Please Change	This card cannot be used with this camcorder. Remove it and load a compatible card.
Cannot Use Media(A)*	A card of a different file system or an unformatted card was inserted. It cannot be used with this camcorder.
Unsupported File System	Replace it or format it with this camcorder.
Media Error	An error occurred with the memory card. The card requires restoration.
Media(A)* Needs to be Restored	Restore the card.
Media Error	Recording cannot be done, because the memory card is defective.
Cannot Record to Media(A)*	Because playback may be possible, it is recommended to replace it with another card after copying the clips, as required.
Media Error	Neither recording nor playback can be done, because the memory card is defective.
Cannot Use Media(A)*	It cannot be operated with this camcorder. Replace it with another card.
Media(A)* Error	Recording or playback stops, because an error occurred with the memory card.
Recording Halted	If this frequently occurs, change the memory card.
Playback Halted	
Media Reached Rewriting Limit	The memory card comes to the end of its service life. Make a backup copy and replace the card with another one as soon as possible. Recording/playback may not be performed properly if you continue to use the card.
Change Media (A)*	<i>For details, refer to the operating instructions of the memory card.</i>
Copy All MPEG2 Proxy	Copying of All the MPEG2 Proxy is not completed because of the displayed reason.
NG: Reached Clip Number Limit	
NG: Same File Already Exists	<ul style="list-style-type: none"> <li>• The maximum number of clips is reached.</li> <li>• There is a file with the same name.</li> <li>• There is not enough capacity for copying.</li> </ul>
NG: Not Enough Capacity	Replace the Media.
Input AES/EBU is Invalid Emphasis	Emphasis signal that is not compatible with the AES/EBU input is input. The camcorder is compatible with 50u-15u Emphasis only.
Input AES/EBU is not Pro Use	Signal other than Professional Use is input to the AES/EBU input. The camcorder is compatible with Professional Use only.
Fan Stopped	The fan in the camcorder has stopped. Avoid use under high temperature conditions. Turn the camcorder off and contact a Sony service representative.
AXS Recorder Fan Stopped	The fan in the AXS-R5 that is connected to the camcorder has stopped. Avoid use under high temperature conditions. Remove the AXS-R5 from the camcorder and contact a Sony service representative.
Abnormal Lens Communication	The type of the connected lens does not match with the camcorder's setting.
Please Check "Lens IF" Setting	Check the "Lens Interface" setting of the Camera menu.

Indication	Cause and measures
Please Execute APR	The auto adjusting of the image sensor (APR) has not been executed for a certain period. Execute APR by pressing the Menu dial.
Invalid setting value was reset: Media/Clip Naming/Camera Position Please save All File again	The setting value of “Clip Naming” is reset because an incorrect All file is loaded. Save the All file again after setting the desired setting value.

\* “Media(B)” for the card in slot B, “AXS Memory” for the AXS memory card.

# Items Saved in the File

LEVEL 1	LEVEL 2	LEVEL 3	All File	Scene File	Lens File
User Menu	Customize Data		○		
Camera	White	Auto White Balance			
		White Switch	○		
		Color Temp.	○		
		Color Temp. Balance	○		
		R Gain	○		
		B Gain	○		
		Shockless White	○		
		Filter White Memory	○		
	Offset White	Setting	○		
		Offset <Memory>	○		
	Black	Auto Black Balance			
		Master Black	○	○	
		R Black	○	○	
		B Black	○	○	
	Flare	Setting	○	○	
		Master Flare	○	○	
		R Flare	○	○	
		G Flare	○	○	
		B Flare	○	○	
	Gain	Mode	○	○	
		Gain	○	○	
		Exposure Index	○	○	
		Highlight Latitude			
		Gain/EI Switch <L>	○		
		Gain/EI Switch <M>	○		
		Gain/EI Switch <H>	○		
		Remote Gain L	○	○	
		Remote Gain M	○	○	
		Remote Gain H	○	○	
		Shockless Gain	○	○	
	Shutter	Setting	○	○	
		Mode	○	○	
		Select	○	○	
		Shutter Value	○	○	
		Step Select	○	○	
	Slow Shutter	Setting	○	○	
		Number of Frames	○	○	
	Auto Exposure	Level	○		
		Speed	○		
		Clip High light	○		
		Detect Window	○		
Detect Window Indication		○			
S&Q Motion	Setting	○			
	High Frame Rate Mode	○			
	Frame Rate	○			



LEVEL 1	LEVEL 2	LEVEL 3	All File	Scene File	Lens File	
	Color Bars	Setting				
		Type	○			
	Noise Suppression	Setting	○	○		
		Level	○	○		
	Flicker Reduce	Mode	○			
		Frequency	○			
	Image Inversion	Setting	○			
	Lens Interface	Setting	○			
		Zoom Limit	○			
	Paint	Gamma	Setting	○	○	
			Step Gamma	○	○	
			Master Gamma	○	○	
			R Gamma	○	○	
			G Gamma	○	○	
B Gamma			○	○		
Gamma Category			○	○		
Gamma Select			○	○		
Black Gamma		Setting	○	○		
		Range	○	○		
		Master Black Gamma	○	○		
Knee		Setting	○	○		
		Point	○	○		
		Slope	○	○		
		Knee Saturation	○	○		
		Knee Saturation Level	○	○		
White Clip		Setting	○	○		
		Level	○	○		
Detail		Setting	○	○		
		Level	○	○		
		H/V Ratio	○	○		
		Crispening	○	○		
		Level Depend	○	○		
		Level Depend Level	○	○		
		Frequency	○	○		
		Knee Aperture	○	○		
		Knee Aperture Level	○	○		
		Limit	○	○		
		White Limit	○	○		
		Black Limit	○	○		
		V Black Limit	○	○		
V Detail Creation		○	○			
Aperture		Setting	○	○		
	Level	○	○			
Skin Detail	Setting	○	○			
	Area Detection					
	Area Indication					
	Level	○	○			
	Saturation	○	○			
	Hue	○	○			
	Width	○	○			

LEVEL 1	LEVEL 2	LEVEL 3	All File	Scene File	Lens File	
	Matrix	Setting	<input type="radio"/>	<input type="radio"/>		
		Preset Matrix	<input type="radio"/>	<input type="radio"/>		
		Preset Select	<input type="radio"/>	<input type="radio"/>		
		User Matrix	<input type="radio"/>	<input type="radio"/>		
		Level	<input type="radio"/>	<input type="radio"/>		
		Phase	<input type="radio"/>	<input type="radio"/>		
		User Matrix R-G	<input type="radio"/>	<input type="radio"/>		
		User Matrix R-B	<input type="radio"/>	<input type="radio"/>		
		User Matrix G-R	<input type="radio"/>	<input type="radio"/>		
		User Matrix G-B	<input type="radio"/>	<input type="radio"/>		
		User Matrix B-R	<input type="radio"/>	<input type="radio"/>		
		User Matrix B-G	<input type="radio"/>	<input type="radio"/>		
		Multi Matrix	Setting	<input type="radio"/>	<input type="radio"/>	
	Area Indication					
	Color Detection					
	Axis					
	Hue		<input type="radio"/>	<input type="radio"/>		
	Saturation		<input type="radio"/>	<input type="radio"/>		
	Audio	Audio Input	Front MIC Select	<input type="radio"/>		
			Rear XLR Auto	<input type="radio"/>		
			Front MIC CH1 Ref	<input type="radio"/>		
			Front MIC CH2 Ref	<input type="radio"/>		
			Rear MIC CH1 Ref	<input type="radio"/>		
			Rear MIC CH2 Ref	<input type="radio"/>		
			MIC CH1 Ref	<input type="radio"/>		
			MIC CH2 Ref	<input type="radio"/>		
			Line Input Ref	<input type="radio"/>		
Limiter Mode			<input type="radio"/>			
1KHz Tone on Color Bars			<input type="radio"/>			
CH-1 Wind Filter			<input type="radio"/>			
CH-2 Wind Filter			<input type="radio"/>			
CH-3 Wind Filter			<input type="radio"/>			
CH-4 Wind Filter			<input type="radio"/>			
MIC CH1 Level			<input type="radio"/>			
MIC CH2 Level			<input type="radio"/>			
Rear1/WRR Level			<input type="radio"/>			
Rear2/WRR Level			<input type="radio"/>			
Audio CH3 Level			<input type="radio"/>			
Audio CH4 Level		<input type="radio"/>				
Audio Level		CH-1 Audio Select	<input type="radio"/>			
		CH-2 Audio Select	<input type="radio"/>			
		CH-1 Audio Level	<input type="radio"/>			
		CH-2 Audio Level	<input type="radio"/>			
		AGC Spec	<input type="radio"/>			
		CH1&2 AGC Mode	<input type="radio"/>			
	CH3&4 AGC Mode	<input type="radio"/>				
	Reference Level	<input type="radio"/>				

LEVEL 1	LEVEL 2	LEVEL 3	All File	Scene File	Lens File
	Audio Output	Output CH	○		
		Monitor CH	○		
		Headphone Out	○		
		Monitor Level	○		
		Reference Out	○		
	WRR Setting	WRR Valid CH Sel	○		
		WRR CH Select	○		
		WRR Delay Comp	○		
		TX	○		
		TX Audio Peak	○		
		TX Input Level	○		
		TX ATT Level	○		
		TX LCF Frequency	○		
	TX System Delay	○			
Video	Output On/Off	SDI(Sub)	○		
		HDMI	○		
	Output Format	SDI(Main)	○		
		SDI(Sub)	○		
		HDMI	○		
		EXT IF			
		TEST			
	Output Setting	4K/2K to HD Conv.	○		
		SD Mode	○		
	Monitor LUT	Category	○		
		LUT Select	○		
		Look Profile Select	○		
		User 3D LUT Select			
		SDI(Main)&Internal Rec	○		
		SDI(Sub)&HDMI	○		
		Viewfinder	○		
	Output Display	VF Out	○		
		4K/QFHD SDI/HDMI Out	○		
		HD/SD SDI(Sub) Out	○		
HD/SD HDMI Out		○			
Forced Menu Disp		○			
VF	VF Setting	Color	○		
		Contrast	○		
		Brightness	○		
		Color Mode	○		
		Aspect	○		
		Double Speed Drive	○		
		Peaking	Setting	○	
	Peaking Type		○		
	Frequency		○		
	Normal Peaking Level		○		
	Color		○		
	Color Peaking Level		○		

LEVEL 1	LEVEL 2	LEVEL 3	All File	Scene File	Lens File
	Marker	Setting	<input type="radio"/>		
		Color	<input type="radio"/>		
		Center Marker	<input type="radio"/>		
		Safety Zone	<input type="radio"/>		
		Safety Area	<input type="radio"/>		
		Aspect Marker	<input type="radio"/>		
		Aspect Select	<input type="radio"/>		
		Aspect Mask	<input type="radio"/>		
		Aspect Safety Zone	<input type="radio"/>		
		Aspect Safety Area	<input type="radio"/>		
		User Box	<input type="radio"/>		
		User Box Width	<input type="radio"/>		
		User Box Height	<input type="radio"/>		
		User Box H Position	<input type="radio"/>		
	User Box V Position	<input type="radio"/>			
	100% Marker	<input type="radio"/>			
	Zebra	Setting	<input type="radio"/>		
		Zebra Select	<input type="radio"/>		
		Zebra1 Level	<input type="radio"/>		
		Zebra1 Aperture Level	<input type="radio"/>		
		Zebra2 Level	<input type="radio"/>		
	Display On/Off	Setting	<input type="radio"/>		
		Shutter Setting	<input type="radio"/>		
		ND Filter Position	<input type="radio"/>		
		Gain Setting	<input type="radio"/>		
		Rec / Play Status	<input type="radio"/>		
		Color Temp.	<input type="radio"/>		
		Frame Rate / Interval	<input type="radio"/>		
		Battery Remain	<input type="radio"/>		
		Timecode	<input type="radio"/>		
		Audio Level Meter	<input type="radio"/>		
		Media Status	<input type="radio"/>		
		Focus Position	<input type="radio"/>		
		Iris Position	<input type="radio"/>		
		Zoom Position	<input type="radio"/>		
		AE Mode	<input type="radio"/>		
		White Balance Mode	<input type="radio"/>		
		SDI Rec Control	<input type="radio"/>		
		Rec Format	<input type="radio"/>		
		Gamma	<input type="radio"/>		
		Timecode Lock	<input type="radio"/>		
		Wi-Fi Condition	<input type="radio"/>		
		Video Signal Monitor	<input type="radio"/>		
Clip Name		<input type="radio"/>			
Focus Assist Indicator		<input type="radio"/>			
Focus Area Marker		<input type="radio"/>			
Clip Number		<input type="radio"/>			
Notice Message	<input type="radio"/>				
WRR RF Level	<input type="radio"/>				

LEVEL 1	LEVEL 2	LEVEL 3	All File	Scene File	Lens File	
TC/UB	Timecode	Mode	<input type="radio"/>			
		Run	<input type="radio"/>			
		Setting				
		Reset				
		TC Format	<input type="radio"/>			
	TC Display	Display Select	<input type="radio"/>			
Recording	Interval Rec	Setting				
		Interval Time	<input type="radio"/>			
		Number of Frames	<input type="radio"/>			
	Picture Cache Rec	Setting	<input type="radio"/>			
		Cache Rec Time	<input type="radio"/>			
	MPEG2 Proxy	Setting	<input type="radio"/>			
	Rec Control	Setting	<input type="radio"/>			
SDI Rec Control	Setting	<input type="radio"/>				
Media	Update Media	Media(A)				
		Media(B)				
		AXS Memory				
	Format Media	Media(A)				
		Media(B)				
		SD Card				
		AXS Memory				
	Clip Naming	Mode	<input type="radio"/>			
		Camera ID	<input type="radio"/>			
		Reel No.	<input type="radio"/>			
		Camera Position	<input type="radio"/>			
		Title Prefix	<input type="radio"/>			
		Number Set				
	File	All File	Load SD Card			
			Save SD Card			
File ID			<input type="radio"/>			
Scene File		Recall Internal Memory				
		Store Internal Memory				
		Load SD Card				
		Save SD Card				
		File ID		<input type="radio"/>		
User Menu Item		Load SD Card				
		Save SD Card				
		File ID				
User Gamma		Current Setting				
		Load SD Card				
		Reset				
Monitor LUT		Current Settings				
		Load SD Card				
		Reset				
Monitor 3D LUT		Current Setting				
		Load SD Card				
		Reset				

LEVEL 1	LEVEL 2	LEVEL 3	All File	Scene File	Lens File	
	LENS File	Recall Internal Memory				
		Store Internal Memory				
		Load SD Card				
		Save SD Card				
		File ID				○
		File Source				
		Clear Lens Offset				
		Lens Auto Recall		○		
		Lens Serial Number				
		Lens Name				
		Lens Manufacturer				
		Lens Center H				○
		Lens Center V				○
		Flare R				○
		Flare G				○
		Flare B				○
		White Offset R				○
		White Offset B				○
		Shading Ch Select				
		Shading H SAW				○
Shading H PARA				○		
Shading V SAW				○		
Shading V PARA				○		
Maintenance	APR	APR				
	Test Saw	Setting	○			
	Camera Config	RM Common Memory	○			
System	System Setting	HD/2K Modulation	○			
		Frequency	○			
	Base Setting	Shooting Mode	○			
		Main Operation	○			
		Color Space	○	○		
		Imager Scan Mode	○			
	Rec Format	Format	○			
	Genlock	Reference				
	Assignable Button	<1>		○		
		<2>		○		
		<3>		○		
		<4>		○		
		<5>		○		
		<6>		○		
		<7>		○		
<8>			○			
Lens RET			○			
Menu Dial Assign			○			
S&Q Frame Rate<1>			○			
S&Q Frame Rate<2>			○			
S&Q Frame Rate<3>			○			
S&Q Frame Rate<4>		○				
S&Q Frame Rate<5>		○				
S&Q Frame Rate<6>		○				

LEVEL 1	LEVEL 2	LEVEL 3	All File	Scene File	Lens File
	Switch / Lamp	Rec Lamp	<input type="radio"/>		
		Lock Switch Setting	<input type="radio"/>		
		Menu Dial Scroll	<input type="radio"/>		
		Menu Dial Direction	<input type="radio"/>		
		Set Key on Thumbnail	<input type="radio"/>		
	Fan Control	Setting	<input type="radio"/>		
	Battery Alarm	Near End:Info Battery	<input type="radio"/>		
		End:Info Battery	<input type="radio"/>		
		Near End:Sony Battery	<input type="radio"/>		
		End:Sony Battery	<input type="radio"/>		
		Near End:Other Battery	<input type="radio"/>		
		End:Other Battery	<input type="radio"/>		
	DC Voltage Alarm	Detected Battery			
		DC Low Voltage1	<input type="radio"/>		
		DC Low Voltage2	<input type="radio"/>		
	Language	Select	<input type="radio"/>		
	Clock Set	Time Zone	<input type="radio"/>		
		Date Mode	<input type="radio"/>		
		12H/24H	<input type="radio"/>		
		Date			
		Time			
	Hours Meter	Hours (System)			
		Hours (Reset)			
		Reset			
	AXS Recorder	Chunk	<input type="radio"/>		
		Version			
		Hours Meter (System)			
		Hours Meter (Reset)			
		Reset Hours Meter			
	Basic Authentication	User Name			
		Password			
	Wi-Fi	Wi-Fi	<input type="radio"/>		
		SSID & Password			
Wi-Fi Direct Connection					
Client					
IP Address					
Subnet Mask					
MAC Address					
Regenerate Password					
All Reset	Reset				
Option	DNxHD/ProRes				
	4K/QFHD XAVC				
	Install Option				
	ID				
Version	Number				
	Version Up				

# Licenses

## MPEG-2 Video Patent Portfolio License

ANY USE OF THIS PRODUCT OTHER THAN CONSUMER PERSONAL USE IN ANY MANNER THAT COMPLIES WITH THE MPEG-2 STANDARD FOR ENCODING VIDEO INFORMATION FOR PACKAGED MEDIA IS EXPRESSLY PROHIBITED WITHOUT A LICENSE UNDER APPLICABLE PATENTS IN THE MPEG-2 PATENT PORTFOLIO, WHICH LICENSE IS AVAILABLE FROM MPEG LA, L.L.C., 250 STEELE STREET, SUITE 300, DENVER, COLORADO 80206.

“PACKAGED MEDIA” means any storage media storing MPEG-2 video information such as DVD movie which are sold/distributed to general consumers. Disc replicators or sellers of the PACKAGED MEDIA need to obtain licenses for their own business from MPEG LA. Please contact MPEG LA for any further information. MPEG LA, L.L.C., 250 STEELE STREET, SUITE 300, DENVER, COLORADO 80206 <http://www.mpegla.com>

## MPEG-4 Visual Patent Portfolio License

THIS PRODUCT IS LICENSED UNDER THE MPEG-4 VISUAL PATENT PORTFOLIO LICENSE FOR THE PERSONAL AND NON-COMMERCIAL USE OF A CONSUMER FOR

- (i) ENCODING VIDEO IN COMPLIANCE WITH THE MPEG-4 VISUAL STANDARD (“MPEG-4 VIDEO”) AND/OR
- (ii) DECODING MPEG-4 VIDEO THAT WAS ENCODED BY A CONSUMER ENGAGED IN A PERSONAL AND NON-COMMERCIAL ACTIVITY AND/OR WAS OBTAINED FROM A VIDEO PROVIDER LICENSED BY MPEG LA TO PROVIDE MPEG-4 VIDEO.

NO LICENSE IS GRANTED OR SHALL BE IMPLIED FOR ANY OTHER USE. ADDITIONAL INFORMATION INCLUDING THAT RELATING TO PROMOTIONAL, INTERNAL AND COMMERCIAL USES AND LICENSING MAY BE OBTAINED FROM MPEG LA, LLC. SEE [HTTP://WWW.MPEGLA.COM](http://WWW.MPEGLA.COM)

MPEG LA is offering licenses for

- (i) manufacturing/sales of any storage media storing MPEG-4 Visual video information
- (ii) distribution/broadcasting of MPEG-4 Visual video information in any manner (such as online video distribution service, internet broadcasting, TV broadcasting). Other usage of this product may be required to obtain license from MPEGLA. Please contact MPEG LA for any further information. MPEG LA, L.L.C., 250 STEELE STREET, SUITE 300, DENVER, COLORADO 80206, <http://www.mpegla.com>

## MPEG-4 AVC Patent Portfolio License

THIS PRODUCT IS LICENSED UNDER THE AVC PATENT PORTFOLIO LICENSE FOR THE PERSONAL USE OF A CONSUMER OR OTHER USES IN WHICH IT DOES NOT RECEIVE REMUNERATION TO

- (i) ENCODE VIDEO IN COMPLIANCE WITH THE AVC STANDARD (“AVC VIDEO”) AND/OR
- (ii) DECODE AVC VIDEO THAT WAS ENCODED BY A CONSUMER ENGAGED IN A PERSONAL ACTIVITY AND/OR WAS OBTAINED FROM A VIDEO PROVIDER LICENSED TO PROVIDE AVC VIDEO.

NO LICENSE IS GRANTED OR SHALL BE IMPLIED FOR ANY OTHER USE. ADDITIONAL INFORMATION MAY BE OBTAINED FROM MPEG LA, L.L.C. SEE [HTTP://WWW.MPEGLA.COM](http://WWW.MPEGLA.COM)



## On accessing software to which the GPL/LGPL applies

This product uses software to which the GPL/LGPL applies. This informs you that you have a right to have access to, modify, and redistribute source code for these software programs under the conditions of the GPL/LGPL.

The source code is provided on the internet. Use the following URL and follow the download instructions.

<http://www.sony.net/Products/Linux/common/search.html>

We would prefer that you do not contact us about the contents of the source code.

For the content of these licenses, see "License1.pdf" in the "License" folder of the supplied CD-ROM.

Adobe Reader must be installed on your computer to view PDF files.

If Adobe Reader is not installed on your computer, you can download it by accessing the following URL.

<http://get.adobe.com/reader/>

## Open software licenses

On the basis of license contracts between Sony and the software copyright holders, this product uses open software.

To meet the requirements of the software copyright holders, Sony is obligated to inform you of the content of these licenses.

For the content of these licenses, see "License1.pdf" in the "License" folder of the supplied CD-ROM.

# Specifications

## General

### Power Requirements

DC 12 V (11 V to 17.0 V)

### Power Consumption

#### PMW-F55

Approx. 25 W (body only, while recording XAVC 4K 59.94P, 4K SDI: On)

#### PMW-F5

Approx. 24 W (body only, while recording XAVC HD 59.94P, HD-SDI: On)

### Notes

- When connecting a device to the DC OUT connector, use one with current consumption of 1.8 A or less.
- When using the camcorder with peripheral devices attached, make sure that the total power consumption of the attached devices is 60 W or less.

### Operating Temperature

0°C to 40°C (32°F to 104°F)

### Storage Temperature

-20°C to +60°C (-4°F to +140°F)

### Mass

Approx. 2.2 kg (4 lb 14 oz) (without lens, handle, audio box, and accessories)

### Dimensions

See "Dimensions" on page 126.

### Battery Operating Time

#### PMW-F55

Approx. 150 min with BP-FL75

#### PMW-F5

Approx. 160 min with BP-FL75

---

### Recording Format (Video)

XAVC  
 AVC/H.264 High 4:2:2 Intra Profile  
 4K/QFHD: VBR, 600 Mbps max.  
 2K: VBR, 220 Mbps max.  
 HD: SMPTE RP2027 Class100 compliant

MPEG HD422  
 MPEG-2 Long GOP  
 HD 422 mode: CBR, 50 Mbps,  
 MPEG-2 422P@HL

SR SStP  
 MPEG-4 Simple Studio Profile  
 HD: SR-SQ 444, SR-SQ 422, SR-Lite 422

Apple ProRes  
 HD: ProRes 422 HQ, ProRes 422

Avid DNxHD®  
 HD: DNxHD 220x (10-bit 4:2:2),  
 DNxHD 145 (8-bit 4:2:2)

---

### Recording Format (Audio)

LPCM 8CH (2CH recording/playback),  
 24-bit, 48-kHz

---

### Recording Frame Rate

#### PMW-F55

XAVC 4K: 4096 × 2160, 23.98P/24P/  
 25P/29.97P/50P/59.94P

XAVC QFHD: 3840 × 2160, 23.98P/  
 25P/29.97P/50P/59.94P

XAVC 2K: 2048 × 1080, 23.98P/24P/  
 25P/29.97P/50P/59.94P

XAVC HD: 1920 × 1080, 23.98P/25P/  
 29.97P/50P/59.94P

MPEG2 HD: 1920 × 1080, 50i/59.94i/  
 23.98P/25P/29.97P

MPEG2 HD: 1280 × 720, 50P/59.94P

SR-SStP: 1920 × 1080, 23.98P/24P/25P/  
 29.97P/59.94i

Apple ProRes: 1920 × 1080, 23.98P/  
 24P/25P/29.97P/50i/59.94i (When the  
 CBK-55PD is installed.)

Avid DNxHD®: 1920 × 1080, 23.98P/  
 25P/29.97P/50i/59.94i (When the  
 CBK-55PD is installed.)

#### PMW-F5

XAVC 4K: 4096 × 2160, 23.98P/24P/  
 25P/29.97P/50P/59.94P (When the  
 CBKZ-55FX is installed.)

XAVC QFHD: 3840 × 2160, 23.98P/  
 25P/29.97P/50P/59.94P (When the  
 CBKZ-55FX is installed.)

XAVC 2K: 2048 × 1080, 23.98P/24P/  
 25P/29.97P/50P/59.94P

XAVC HD: 1920 × 1080, 23.98P/25P/  
 29.97P/50P/59.94P

MPEG2 HD: 1920 × 1080, 50i/59.94i/  
 23.98P/25P/29.97P

SR-SStP: 1920 × 1080, 23.98P/24P/25P/  
 29.97P/59.94i

Apple ProRes: 1920 × 1080, 23.98P/  
 24P/25P/29.97P/50i/59.94i (When the  
 CBK-55PD is installed.)

Avid DNxHD®: 1920 × 1080, 23.98P/  
 25P/29.97P/50i/59.94i (When the  
 CBK-55PD is installed.)

---

### Recording/Playback Time

When SBS-32G1A is used  
 MPEG2 HD: Approx. 60 min

When SBS-64G1A is used  
 MPEG2 HD: Approx. 120 min

When SBP-32 is used  
 XAVC HD 23.98P: Approx. 36 min  
 XAVC HD 25P: Approx. 35 min  
 XAVC HD 29.97P: Approx. 30 min  
 SR-Lite 422 23.98P: Approx. 18 min  
 SR-Lite 422 25P: Approx. 17 min  
 SR-Lite 422 29.97P: Approx. 14 min  
 ProRes 422 23.98P: Approx. 26 min  
 ProRes 422 25P: Approx. 25 min  
 ProRes 422 29.97P: Approx. 20 min  
 DNxHD 145 23.98P: Approx. 28 min  
 DNxHD 145 25P: Approx. 27 min  
 DNxHD 145 29.97P: Approx. 23 min

When SBP-64A is used  
 XAVC HD 23.98P: Approx. 72 min  
 XAVC HD 25P: Approx. 70 min  
 XAVC HD 29.97P: Approx. 60 min  
 SR-Lite 422 23.98P: Approx. 38 min  
 SR-Lite 422 25P: Approx. 36 min  
 SR-Lite 422 29.97P: Approx. 30 min

ProRes 422 HQ 23.98P: Approx. 35 min  
 ProRes 422 25P: Approx. 34 min  
 ProRes 422 29.97P: Approx. 28 min  
 DNxHD 220x 23.98P: Approx. 38 min  
 DNxHD 220x 25P: Approx. 36 min  
 DNxHD 220x 29.97P: Approx. 31 min

When SBP-64B is used

XAVC 4K 25P: Approx. 24 min  
 XAVC 4K 29.97P: Approx. 20 min  
 SR-SQ 422/444 23.98P: Approx. 18 min  
 SR-SQ 422/444 25P: Approx. 17 min  
 SR-SQ 422/444 29.97P: Approx. 14 min

When SBP-128B is used

XAVC 4K 23.98P: Approx. 52 min  
 XAVC 4K 25P: Approx. 50 min  
 XAVC 4K 29.97P: Approx. 40 min  
 SR-SQ 422/444 23.98P: Approx. 40 min  
 SR-SQ 422/444 25P: Approx. 38 min  
 SR-SQ 422/444 29.97P: Approx. 30 min

**Note**

These approximate recording/playback times depend on operating conditions, available memory, etc.

## Camera Section

### Imaging Device

#### PMW-F55

Super 35mm equivalent Single-chip CMOS with the frame image scan function

#### PMW-F5

Super 35mm equivalent Single-chip CMOS

### Imaging Device (Pixel Count)

11.6 M (total), 8.9 M (effective)

### Built-in Filters

Clear, 0.9 (1/8ND), 1.8 (1/64ND)

### Sensitivity (2000 lx, 89.9% reflectance)

#### PMW-F55

Video Gamma: T12@24p (3200K Light source)

#### PMW-F5

Video Gamma: T14@24p (3200K Light source)

### ISO Sensitivity

#### PMW-F55

S-Log2 Gamma: ISO 1250 (D55 Light source)

#### PMW-F5

S-Log2 Gamma: ISO 2000 (D55 Light source)

### Lens Mount

PL mount (with supplied lens mount adaptor)

### Flange Focal Length

FZ mount (without supplied lens mount adaptor)

### Latitude

14-stop

### S/N Ratio

57 dB (Video Gamma, Noise Suppression: OFF)

### Shutter Speed

1/24s to 1/6,000s (23.98P)

### Shutter Angle

4.2° to 359.7° (electronic shutter)

### Slow Shutter (SLS)

2, 3, 4, 5, 6, 7, and 8-frame accumulation

### Slow & Quick Motion Function

XAVC 4K/QFHD: 1P to 60P  
 XAVC 2K/HD: 1P to 180P

### White Balance

Preset (3200K, 4300K, 5500K), Memory

### Gain

-3, 0, 3, 6, 9, 12, 18 dB

---

## Gamma Curve

STD1, STD2, STD3, STD4, STD5,  
STD6  
HG1, HG2, HG3, HG4, HG7, and HG8  
S-Log2, S-Log3

---

## Input/Output

---

### Audio Input

CH-1/CH-2: XLR-type 3-pin (female)  
(×2), LINE / AES/EBU / MIC /  
MIC+48V selectable

---

### Video Output

TEST OUT: BNC (×1)

---

### DC Input

XLR-type 4-pin (male), 11 V to 17 V  
DC

---

### DC Output

4-pin (×2), 11 V to 17 V DC (MAX)  
1.8 A) w/ battery adaptor  
You can output the REC Tally signal and  
input the REC Trigger signal through the  
DC OUT connector.

#### Note

When connecting a device to the DC OUT  
connector, use one with current consumption  
of 1.8 A or less.

---

### SDI Output

BNC (×4)  
3G-SDI: SMPTE ST424/425 Level-B  
HD SDI: SMPTE ST292 compliant  
SD SDI: SMPTE-259M compliant

---

### PMW-F55

HD mode:  
SDI 1/2: Line Output  
SDI 3/4: Monitor Output  
4K mode:  
SDI 1/2/3/4: Line Output  
Display On/Off switchable

---

### PMW-F5

SDI 1/2: Line Output  
SDI 3/4: Monitor Output

---

### Timecode Input/Output

TC IN/OUT: BNC (×1) switchable

---

---

### Genlock Input

BNC (×1)

---

### Remote

8-pin (×1)

---

### HDMI Output

A Type (×1)

---

### USB

USB device, Mini-B (×1)  
USB host, type-A (×1)

---

### USB Wireless LAN Module Connector

USB host, type-A (×1)

---

### Headphone Output

Stereo mini jack (×1)

---

### Speaker Output

Monaural

---

## Media

---

### Type

ExpressCard/34 slot (×2)  
SD card slot (×1)

---

## Package Configuration

Lens mount adaptor (1)  
Battery adaptor (1)  
Audio input connector (1)  
Screws for the audio input connector (4)  
Tape measure hook (1)  
USB wireless LAN module IFU-WLM3 (1)  
Before Using this Unit (1)  
Operating Instructions (CD-ROM) (1)

---

### Software Downloads

When the unit is used with a PC connection,  
download device drivers, plug-ins, and  
application software, where applicable, from the  
Sony Professional products web site.

Sony Professional products web site homepage:  
U.S.A. <http://pro.sony.com>  
Canada <http://www.sonybiz.ca>  
Latin America <http://sonypro-latin.com>

Europe, Middle East and Africa	<a href="http://www.pro.sony.eu">http://www.pro.sony.eu</a>
Japan	<a href="http://www.sonybsc.com">http://www.sonybsc.com</a>
Asia Pacific	<a href="http://pro.sony-asia.com">http://pro.sony-asia.com</a>
Korea	<a href="http://bp.sony.co.kr">http://bp.sony.co.kr</a>
China	<a href="http://pro.sony.com.cn">http://pro.sony.com.cn</a>

Although the data regarding recorded materials are stored over multiple files and folders, you can easily handle the clips without considering its data and directory structure, by using the dedicated application software.

#### Note

If you perform operations, such as copy, on clips on the SxS memory card by using the Explorer (Windows) or Finder (Macintosh), the subsidiary data contained by the clips may not be maintained.

## Optional Accessories

PL mount wide angle zoom lens

SCL-P11X15

PL lens

SCL-PK6/F, PK6/M (set of 6 lenses, 20 mm/25 mm/35 mm/50 mm/85 mm/135 mm)

SCL-PK3/F, PK3/M (set of 3 lenses, 20 mm/25 mm/135 mm)

FZ mount power zoom lens

SCL-Z18X140

LCD color viewfinder

DVF-L350, DVF-L700

OLED color viewfinder

DVF-EL100

Microphone

ECM-680S (EC-0.5X5F3M), ECM-678, ECM-674

Shoulder adaptor

VCT-FSA5

Battery pack

BP-FL75, BP-L80S

AC adaptor

AC-DN2B, AC-DN10

SxS memory card

SxS PRO+ Series

SxS PRO Series

SxS-1 Series

SD card

SDHC memory card, SD memory card

Portable memory recorder

AXS-R5

AXS memory card

AXS-512S24, AXS-A512S24, AXS-A1TS24

SxS memory card USB reader/writer  
SBAC-US20

AXS memory card reader  
AXS-CR1

Remote control unit

RM-B170, RM-B750, CBK-DCB01

B4-FZ mount adapter

LA-FZB1, LA-FZB2

Optical 2K Filter

CBK-55F2K

Camera system adaptor

CA4000

EFP style buildup kit

CBK-55BK

Sensor upgrade kit

CBK-55UK

Additional codec board

CBK-55PD

4K upgrade license (for PMW-F5)

CBKZ-55FX

Design and specifications are subject to change without notice.

# Dimensions

Unit: mm (inches)

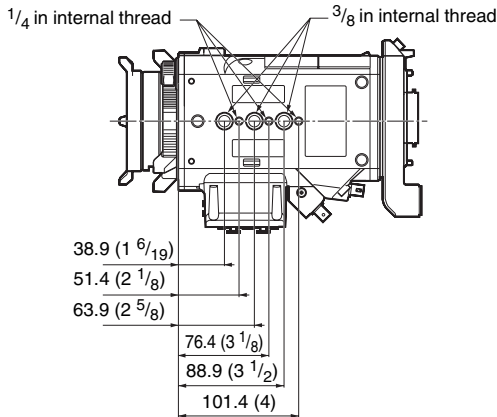
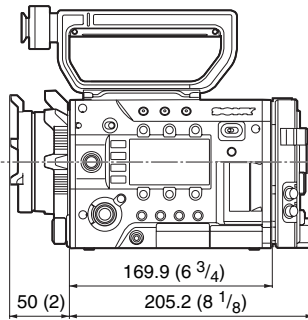
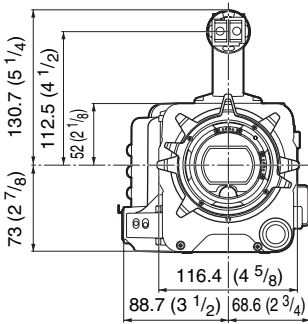
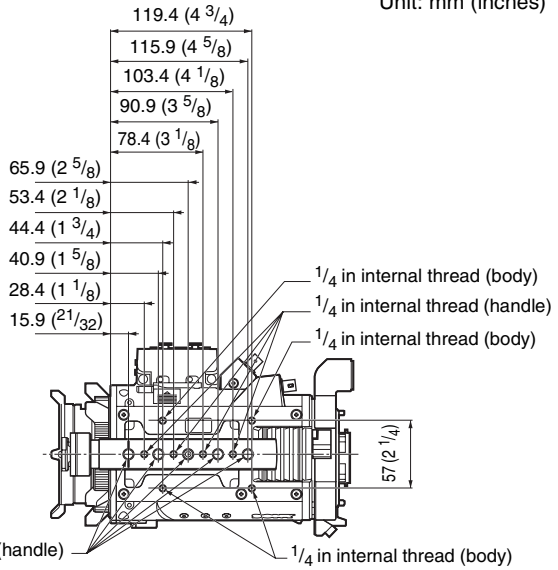

## Notes

- Always make a test recording, and verify that it was recorded successfully.

SONY WILL NOT BE LIABLE FOR DAMAGES OF ANY KIND INCLUDING, BUT NOT LIMITED TO, COMPENSATION OR REIMBURSEMENT ON ACCOUNT OF FAILURE OF THIS UNIT OR ITS RECORDING MEDIA, EXTERNAL STORAGE SYSTEMS OR ANY OTHER MEDIA OR STORAGE SYSTEMS TO RECORD CONTENT OF ANY TYPE.

- Always verify that the unit is operating properly before use. SONY WILL NOT BE LIABLE FOR DAMAGES OF ANY KIND INCLUDING, BUT NOT LIMITED TO, COMPENSATION OR REIMBURSEMENT ON ACCOUNT OF THE LOSS OF PRESENT OR PROSPECTIVE PROFITS DUE TO FAILURE OF THIS UNIT, EITHER DURING THE WARRANTY PERIOD OR AFTER EXPIRATION OF THE WARRANTY, OR FOR ANY OTHER REASON WHATSOEVER.

# Index

## A

AC Adaptor 23  
AC Power 24  
ACCESS lamp 30, 32  
All File 86  
All Reset 95  
Aperture 70  
APR 89  
Assignable Button 43, 92  
AU/TC screen 54  
Audio 40, 43  
Audio Input 73  
Audio Level 43, 75  
Audio menu 73  
Audio Output 75  
Auto Exposure 65  
AXS memory card 33  
AXS Recorder 94  
AXS-R5 33

## B

Base Setting 90  
Basic Authentication 94  
Battery Alarm 93  
Battery Pack 23  
Black 60  
Black Gamma 68  
Built-in speaker 40

## C

Camera Config 89  
Camera menu 59  
CAMERA screen 52  
Caution and Operation Confirmation  
  Indications 110  
Clip 41, 48, 97  
Clip name 41  
Clip Naming 85  
Clock 24  
Clock Set 94  
CMOS Image Sensors 100  
Color Bars 67  
Color space 28  
Color temperature 42

Cueing up 40

## D

DC IN Power 24  
DC Voltage Alarm 93  
Detail 70  
Display Clip Properties 49  
Display On/Off 82

## E

Electronic Shutter 42  
Error Indications 109  
ExpressCard slot 97  
External Monitor 96  
External Synchronization 98

## F

False Color Display 46  
Fan Control 93  
File menu 86  
FILE screen 53  
Flange focal length 26  
Flare 61  
Flicker Reduce 67  
Focus Magnifier 46  
Format 30, 32, 34  
Format Media 85

## G

Gain 42, 61  
Gamma 68  
Genlock 92, 98  
GENLOCK IN connector 98

## H

HDMI OUT connector 96, 105  
Headphones connector 40  
Hours Meter 94

## I

Image Inversion 67  
Interval Rec 84  
Interval Rec Function 44

## K

Knee 69



## L

Language 93  
Lens 25  
Lens File 88  
Lens Interface 67

## M

Main recorded signal 27  
Maintenance menu 89  
Marker 81  
Matrix 71  
Media Full 31  
Media menu 85  
Media Near Full 31  
MENU button 56  
MENU dial 51, 56  
Monitor 3D LUT 87  
Monitor LUT 78, 86  
MPEG2 Proxy 49, 84  
Multi Matrix 72

## N

ND Filter 11  
Nonlinear editing 97

## O

Offset White 60  
Option 95  
OPTION button 48  
Output Display 79  
Output Format 77  
Output Setting 77  
Output signal 101

## P

Paint menu 68  
Peaking 80  
Picture Cache Function 45  
Picture Cache Rec 84

## R

REC button 40  
Rec Control 84  
Rec Format 91  
Rec Review 46  
Recording menu 84

## S

S&Q Motion 66  
SBAC-US20 97  
Scene File 86  
SD memory card 32  
SDHC memory card 32  
SDI OUT connector 96, 101  
SDI Rec Control 84  
SEL/SET dial 51, 56  
Sensitivity 42  
Setting value file 32  
Setup menu 56, 59  
Shooting mode 27  
Shutter 64  
Simultaneously recording 45, 46  
Skin Detail 71  
SLOT SELECT button 30  
Slow & Quick Motion 44  
Slow Shutter 65  
Status screen 12, 19  
Sub display 17, 51  
Sub display setting items 52  
Switch/Lamp 93  
SxS Device Driver Software 97  
SxS Memory Cards 29  
System frequency 27  
System menu 90  
System Setting 90

## T

TC connector 98  
TC Display 83  
TC/UB menu 83  
TEST OUT connector 96, 108  
Test Saw 89  
Thumbnail menu 48  
Thumbnail screen 47  
Time and date 24  
Time Data 43  
Time Zone 24  
Timecode 43, 83, 98

## U

Update Media 85  
USB cable 97  
USB wireless LAN module 35  
User Gamma 86

User Menu 57  
User Menu Item 86  
UTC 24

## **V**

Version 95  
VF menu 80  
VF Setting 80  
Video format 101  
Video menu 77  
Viewfinder 20, 26  
Viewfinder double speed drive function 46

## **W**

Warning Indications 109  
White 59  
White balance 42  
White Clip 69  
Wi-Fi 94  
Wi-Fi remote commander 36  
WRR Setting 76

## **Z**

Zebra 81

