

Osprey Elite S Pedestal

OSPREY elite S Pedestal



Part No. V4172-0001
V4172-0002

Copyright © 2022
All rights reserved.

Original Instructions: English

All rights reserved throughout the world. No part of this publication may be stored in a retrieval system, transmitted, copied or reproduced in any way, including, but not limited to, photocopy, photograph, magnetic or other record without the prior agreement and permission in writing of the Videndum Group Plc.

Disclaimer

The information contained in this publication is believed to be correct at the time of printing. Videndum Ltd reserves the right to make changes to the information or specifications without obligation to notify any person of such revision or changes. Changes will be incorporated in new versions of the publication.

We are making every effort to ensure that our publications are updated on a regular basis to reflect changes to product specifications and features. Should this publication not contain information on the core functionality of your product, please let us know. You may be able to access the latest revision of this publication from our website.

Videndum Production Solutions Ltd reserves the right to make changes to product design and functionality without notification.

Trademarks

All product trademarks and registered trademarks are the property of The Videndum Group Plc.

All other trademarks and registered trademarks are the property of their respective companies.

Published by:

Videndum Production Solutions Ltd

Email: technical.publications@videndum.com

Safety	2	Pressurizing from an external pressure source	17
Warning Symbols Used in these Instructions	2	Balancing the Payload	18
Intended Use	2	Operation	20
Health and Safety	2	Height adjustment	20
Mounting and Installation	2	Drag control	20
Water, Moisture and Dust	3	On-shot clamp	20
Operating Environment	3	Brakes	21
Cleaning	3	Cable guards	21
Maintenance	3	Steering	22
Critical Data	3	Steering Tiller	23
Usage	4	Changing the skid tracking width	24
About this Guide	4	Optional wheels	25
Introduction and Description	4	Transportation and storage	26
Components and Connections	5	Maintenance	27
Box Contents	5	Servicing	28
Optional Accessories	8	General	28
Assembling the Pedestal	9	Cleaning	28
Installation	9	Routine Maintenance	28
Column	10	Adjustments	28
Fitting the Payload	12	Skid clamp adjustment	29
Heavy Duty Quickfix Adaptor (supplied)	12	Technical Specification	30
Pressurizing the pedestal	15	General Notices	32
Pressurizing the pedestal using a portable pump	16		

Safety

Important information on the safe installation and operation of this product. Read this information before operating the product. For your personal safety, read these instructions. Do not operate the product if you do not understand how to use it safely. Save these instructions for future reference.

Warning Symbols Used in these Instructions

Safety cautions are included in these instructions. These safety instructions must be followed to avoid possible personal injury and avoid possible damage to the product.



WARNING!

Where there is a risk of personal injury or injury to others, comments appear supported by the warning triangle symbol.

Where there is a risk of damage to the product, associated equipment, process or surroundings, comments appear supported by the word '**CAUTION**'.



WARNING symbols on the pedestal

On encountering the warning triangle and open book symbols it is imperative that you consult this operators guide before using this pedestal or attempting any adjustment or repair.



Intended Use

The Osprey Elite S pedestal is designed for use in television studios (**OB version field applications**) and on location to support and balance a pan and tilt head, camera and ancillary equipment weighing up to 80 kg (176 lb).

This product is intended for use on an unobstructed and reasonably level surface by television camera operators.

Health and Safety



WARNING! Risk of personal injury or injury to others. All personnel must be fully trained and adhere to correct manual handling techniques and Health & Safety regulations. It is the responsibility of the local organisation to enforce safe working practices at all times..



WARNING! 50.5 kg/176 lb LIFTING ASSISTANCE REQUIRED. Do not lift this product without the assistance of another person or a lifting hoist capable of safely lifting the product.

Mounting and Installation



WARNING! Before fitting, adjusting, or removing the payload, the elevation column must be lowered to a safe working height and wheel brakes must be applied



WARNING! An abnormal or unbalanced payload can cause the product to become unstable. Strictly adhere to the payload guidelines and mounting instructions presented in this user guide



WARNING! When mounting the payload, sufficient clearance must be provided below the mounting platform to prevent the risk of collisions or trapping injuries when the column is lowered.



WARNING! The product has been designed for mounting a payload consisting of camera support equipment only. Under no circumstances should the product be used for the transportation or support of personnel.



WARNING! Risk of product instability when moving the product with the elevation column fully extended. Reduce the height of the elevation column to a safe lower level before attempting to move the product.



WARNING! The product must only be operated on a smooth and level surface.



WARNING! The product must always be secured (all three wheel brakes applied) when left unattended. Do not leave the product unattended on a sloping surface.



CAUTION! Do not exceed the payload limit for the product of 80 kg (176 lb).



CAUTION! The product must only be operated with a minimum payload of 10 kg (22 lb) to pre-load the column correctly.

Water, Moisture and Dust



WARNING! Protect the product from water, moisture and dust.

Operating Environment



WARNING! The product should not be used outside the operating temperature limits. Refer to the product technical specifications for the operating limits for the product.

Cleaning



CAUTION! Do not use solvent or oil-based cleaners, abrasives or wire brushes. Clean with a dry lint free cloth.

Maintenance



WARNING! The fitting of non-approved parts or accessories, or the carrying out of non-approved alterations or servicing can be dangerous and could affect the safety of the product. It may also invalidate the terms and conditions of the product warranty.

Critical Data

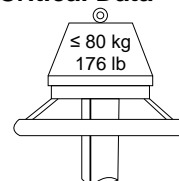

Load

Maximum load: 80 kg / 176 lb

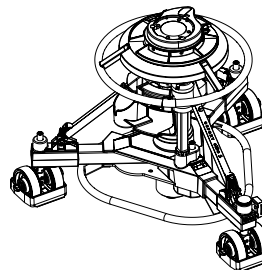

Mass

Pedestal unladen:
 Studio 46.6 kg / 102.8 lb
 OB 50.5 kg / 111.4 lb



Pressure

Maximum pressure: . . . 15 bar (218 psi)

15 bar (218 psi)

Usage

The Osprey Elite S pedestal is designed for use in television studios and on location to support and balance a pan and tilt head, camera and ancillary equipment weighing up to 80 kg / 176 lb. This product is intended for use on an unobstructed and reasonably level surface by television camera operators.



WARNING!

Do NOT attempt to use this product if you do not understand how to operate it.

Do NOT use this product for any other purpose than that specified in the Usage statement above.

Maintenance beyond that detailed in this Operators Guide must be performed only by competent personnel in accordance with the procedures.

About this Guide

This operators guide is issued for the Osprey Elite S Pedestals, Part No. Studio: V4172-0001 and OB: V4172-0002. The guide provides instructions for operation and routine maintenance.

Introduction and Description

The Osprey Elite S is a portable, fully functioning studio and OB pedestal for large payloads up to 80kg / 176lb. It is the most versatile pedestal, capable of supporting large Vinten Vector Heads and the latest range of portable or full facility digital cameras and teleprompters.

It can track talent eye lines from a seated to standing position 'on shot' with its extended fully balanced range. It has an inlet valve for any air source, making Perfect Balance easy to achieve. There is a storage area for the camera operator. In addition, the Osprey Elite S pedestal includes a pressure gauge for clear and reliable set-up and the detachable skid allows the pedestal to be simply broken

down into two sections for easy storage and transportation. It has a selector for both single wheel and all wheel crab steering for working in tight spaces and on shot direction changes. It comes with 12.5cm / 5 inch wheels and adjustable cable guards for studio use, (16cm / 6.3 inch wheels for greater ground clearance in outside broadcast applications).

Key features:

Upper and lower stage have perfect balance for on-shot performance.

Full crab and steer facilities controlled from a central steering ring for enhanced manoeuvrability and on-shot steering.

Built in pressure gauge and manual pump for easy counterbalance set-up.

Detachable skid for easy transport and storage.

Wheel rim braking mechanism eliminates tyre flat spots for smooth rolling shots

Pedestal supplied with Quickfix quick release system & operator storage area

Column can be adapted to work on dolly track



Scan this QR code to access a dedicated page containing important information:

- Safety / educational videos
- Exploded diagrams leading to the Parts Store
- Recycling information and life cycle upgrades
- Warranty information & links to registration / submit case to service team/case management
- User manuals
- Easy access to service centre
- This QR code is also on the Pedestal for easy reference.

Box Contents

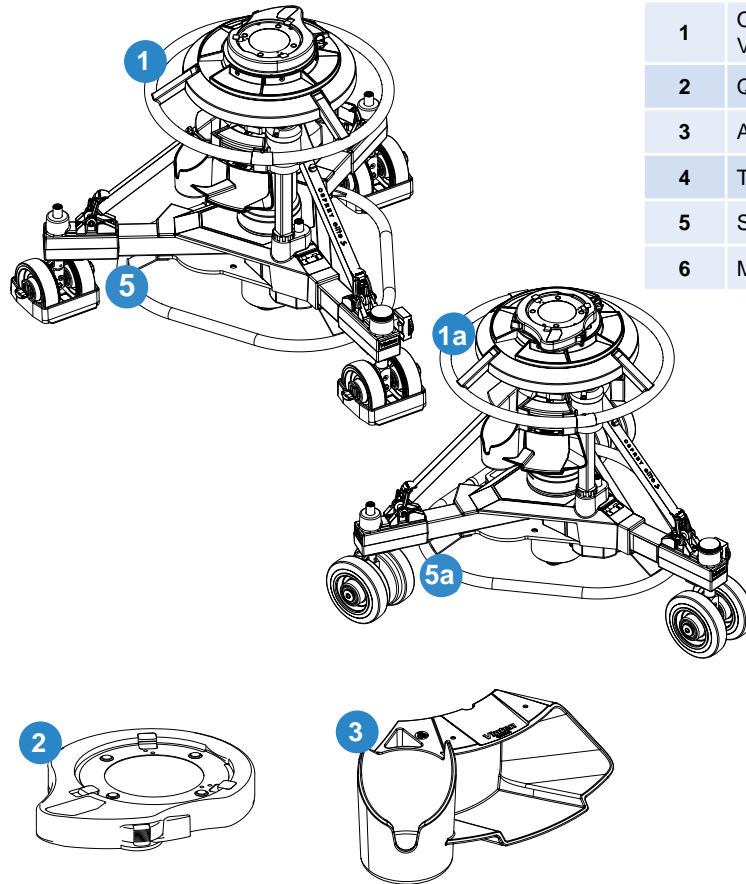

Item	Description	Item	Description
1	Osprey Elite S V4172-0001	1a	Osprey Elite S OB V4172-0002
2	Quickfix	2	Quickfix
3	Accessory holder	3	Accessory holder
4	Trim weights x 6	4	Trim weights x 6
5	Skid + Studio wheels	5a	Skid + OB wheels
6	Manual Pump	6	Manual Pump

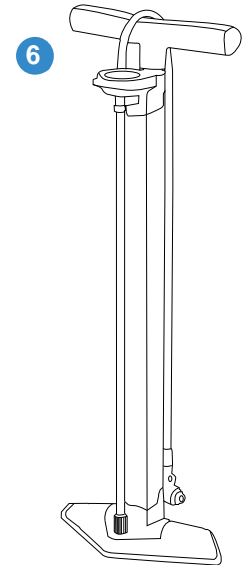

Components and Connections

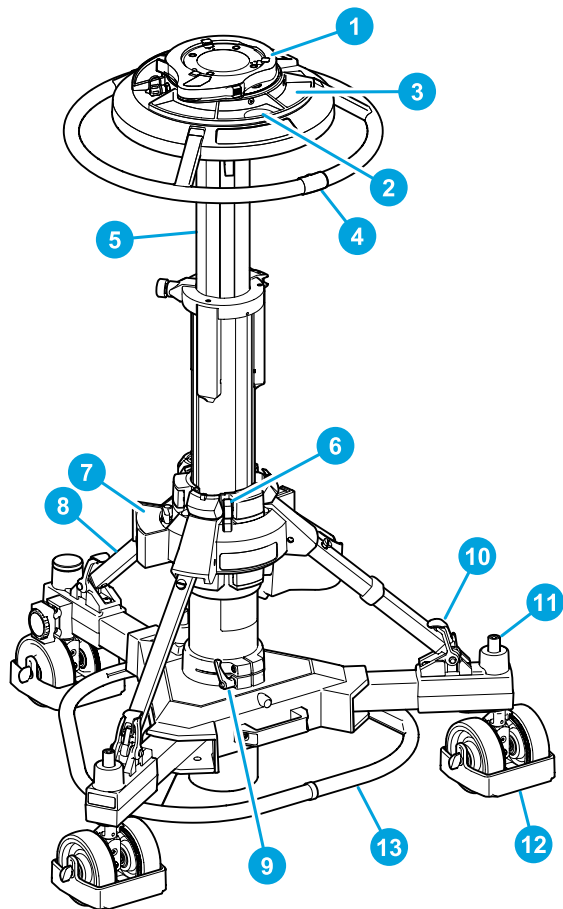

Item	Description
1	Four-bolt mounting plate
2	Pressure gauge
3	Weight tray
4	Steering indicator
5	Moving column
6	Safety catch
7	Trim weight
8	Fixed strut
9	Skid clamp
10	Foot support and strap
11	Wheel brake foot-button
12	Cable guard
13	Kick ring

Components and Connections

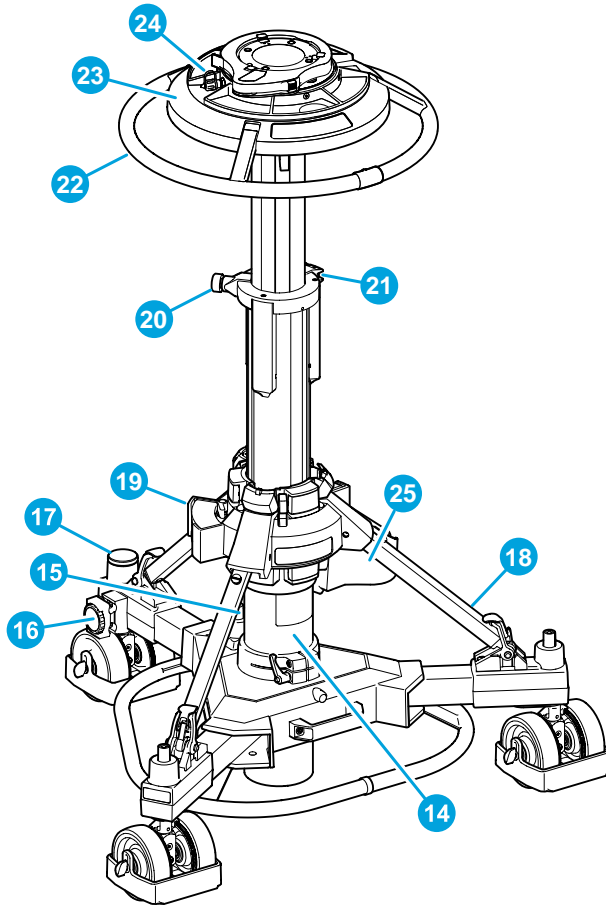

Item	Description
14	Outer Tube
15	Crab/steer changeover foot-button
16	Cable clamp
17	Tiller socket
18	Adjustable strut
19	Trim weight stowage
20	Drag control
21	On-shot clamp
22	Removable steering ring
23	Steering ring mounting plate
24	Schrader valve and cap
25	Accessory holder

Components and Connections

Optional Accessories

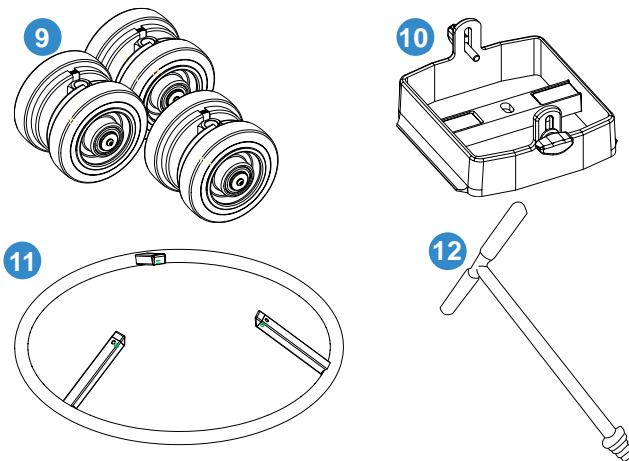
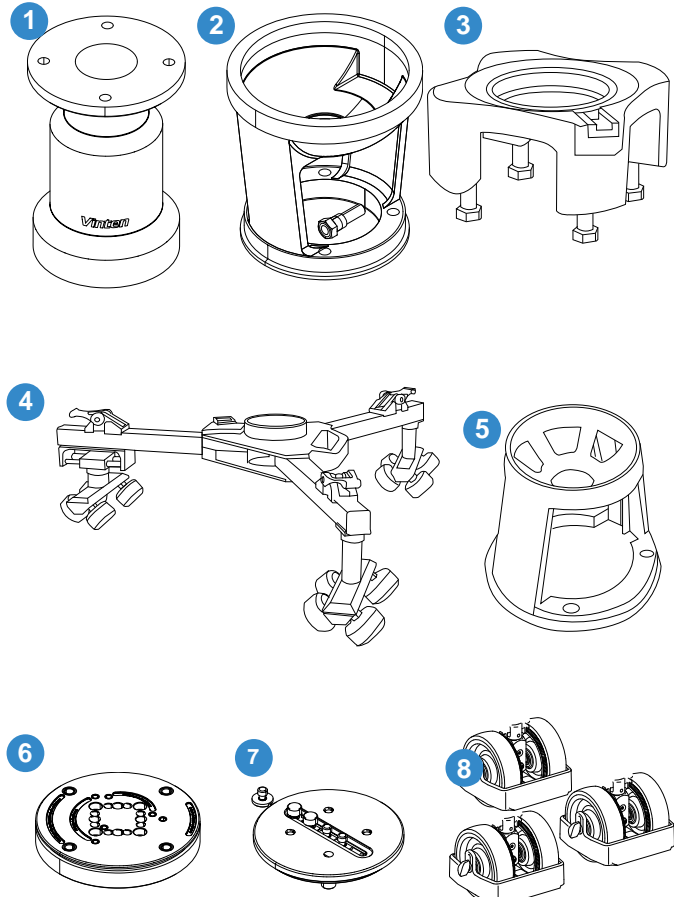

Item	Description	Part No.
1	200mm Hi-Hat	3155-3B
2	150mm Bowl Adaptor	3330-17
3	Mitchell head Adaptor	3055-3B
4	Tracking Dolly / Skid	3369-57
5	100mm Bowl Adaptor	3330-16
6	Base Adaptor	08349
7	PTZ and Prompter plate	V4166-1002
8	Studio Wheels	3329-43
9	OB Wheels	3329-30
10	OB Cable Guards	3329-44
11	Steering Ring Large: 25in	3429-21
12	Tiller Bar	3329-21

Assembling the Pedestal

1. Turn the skid upside-down, depress the leg locking plungers and swing each folding leg out until the plungers lock the legs in the fully open position.
2. Fit the Kick Ring (2), by pressing it into all three sliding catches on the underside of the centre casting (Step 1) and secure it by engaging all three locks (Step 2). The weld line on the kick bar should be aligned with the handle on the skid.
3. Set the skid on the ground on its wheels and apply the brakes (4).
4. Ensure that the rubber straps on each foot support (3) are to the outside of the ball joint.

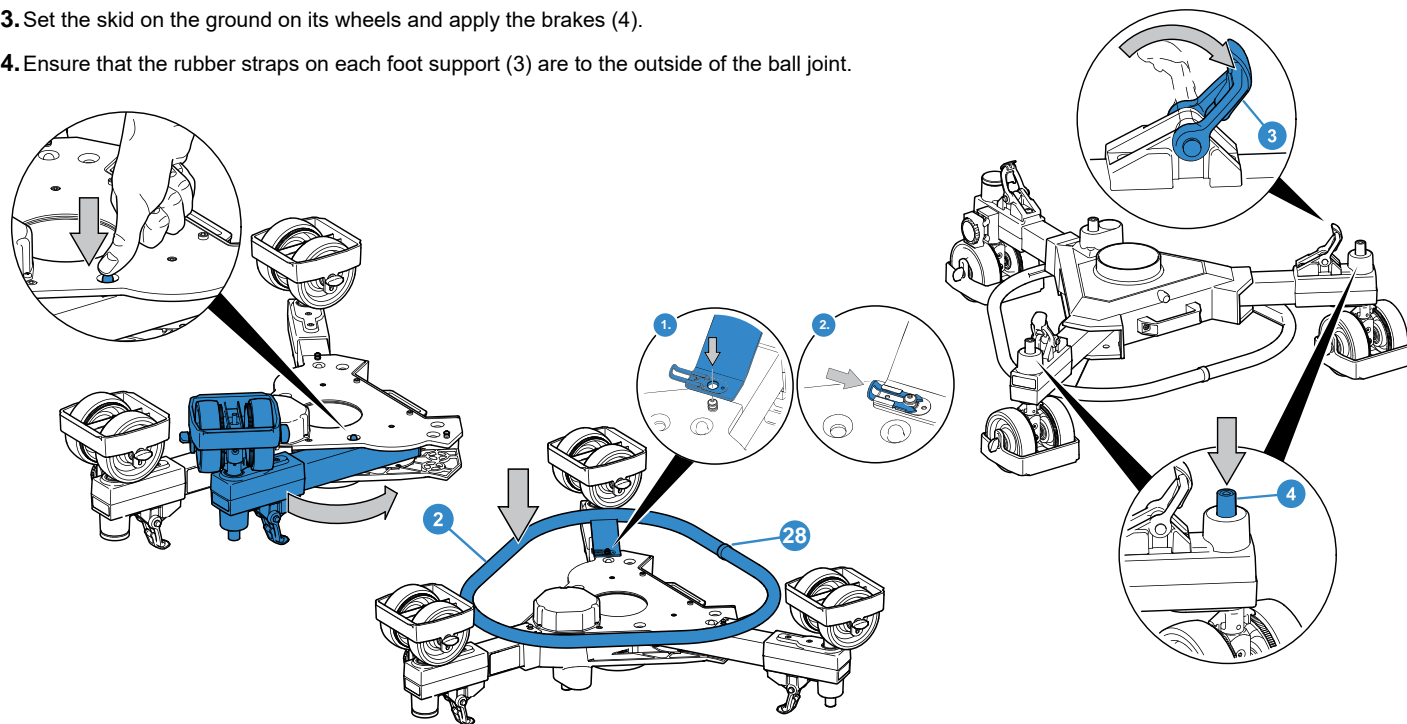

Column

Install the column on the skid as follows:

1. Ensure that the rubber straps on each foot support (10) are to the outside of the ball joint.
2. Hold the column upright. Raise the struts (8 and 18) to about 30° from horizontal. The strut joints are adjusted to retain the strut in this position.
3. Lift the column, align the fixed strut with the fixed leg of the skid (there is also an engraving on the skid to assist aligning the column) and carefully lower the column base into the skid centre. Ensure that the struts engage with the ball joints on each foot support and the steering tube locates in its socket.
4. Secure the struts to the supports with the rubber straps (10).

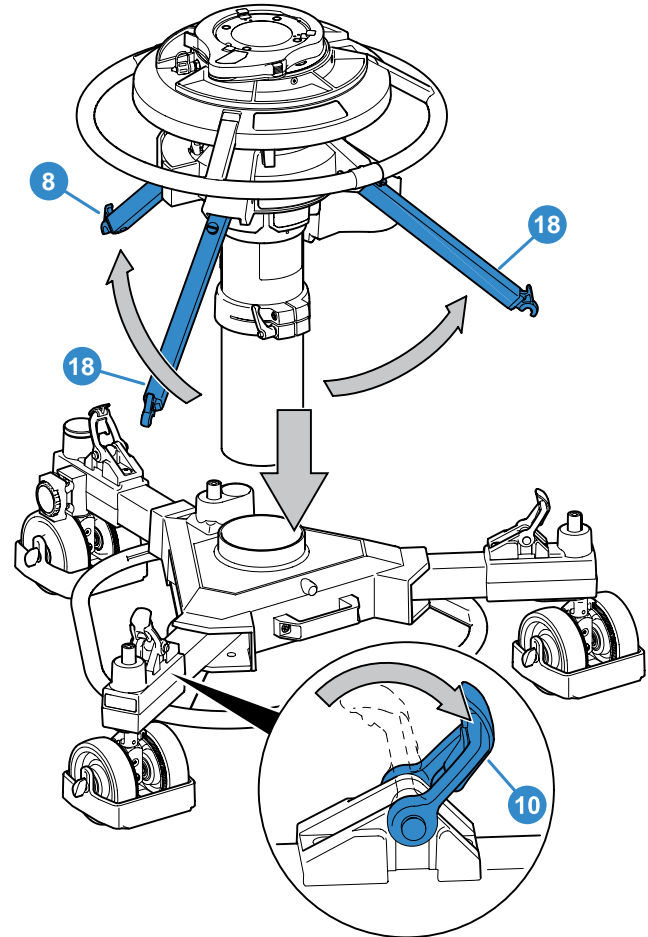

5. Tighten the skid clamp (9), using moderate hand pressure only. The clamp lever has a spring-loaded ratchet-type action and is operated as follows:
6. Turn the clamp lever clock-wise as far as possible.
7. Pull the lever outward against the spring pressure, return it to vertical and release.
8. Turn lever clockwise again.
9. Repeat until the skid clamp is sufficiently tightened.
10. Slide the steering indicator(s) (4) to the desired position (See **Steering** on page 22)

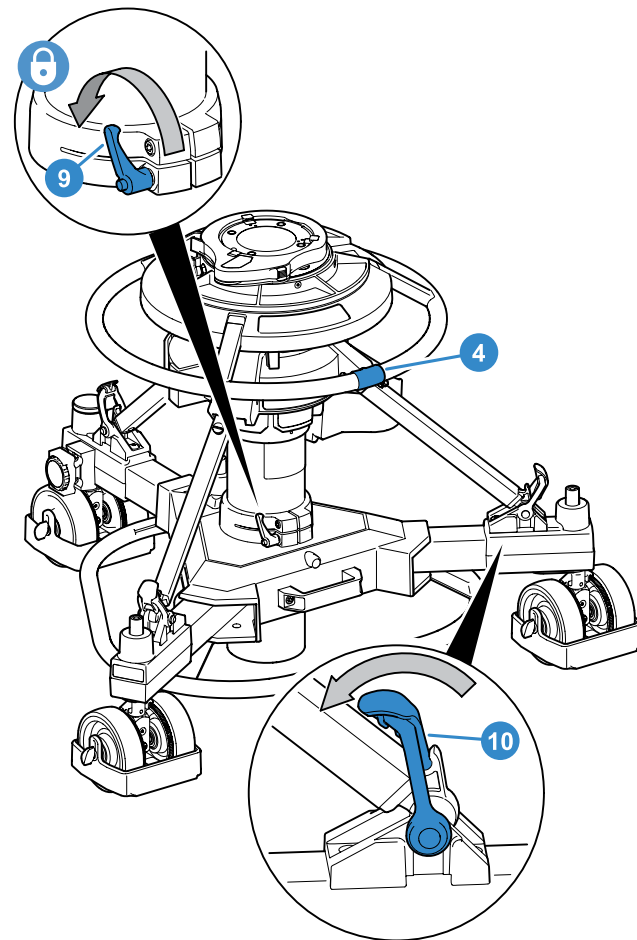

Installation

Fitting the Payload

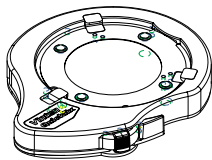

WARNING! Fit the camera mounting and payload with the moving column depressed and the safety catch engaged.

The pedestal has the standard four-bolt mounting plate which permits the use of various Vinten camera mounts including pan and tilt heads, Quickfix and Mitchell adapters See **Optional Accessories** on page 8.

Heavy Duty Quickfix Adaptor (supplied)

The heavy duty Quickfix adaptor allows a pan and tilt head with a 'Quickfix' base to be installed on a standard Vinten four-hole mounting.

Installation

1. Install the adaptor on the four-hole mounting. The mounting bolts are captive in the pedestal and the bolt heads are accessible from the underside of the mounting plate. When the camera mount has been fitted, the bolts should be tightened securely using a spanner of the correct size. A Vinten spanner, Part No. J551-001, is available for this purpose.



WARNING! Ensure that the screws engage sufficiently for safety, but do not protrude above the adaptor mounting face.

To fit a head

1. Push up the red safety latch and unlock the adaptor by pulling the lever fully outwards and to the left.
2. Position the head in the adaptor, ensuring that it seats correctly in the recess and the safety button is depressed.
3. Lock the head in the adaptor by pushing the lever fully inwards to the right until the red safety latch operates.

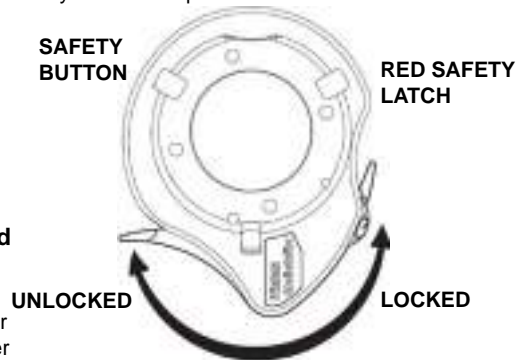

To remove a head

1. Push up the red safety latch and unlock the adaptor by pulling the lever fully outwards and to the left.



WARNING! This unit contains a spring under tension. Removal of the backplate may cause personal injury.

1. Fit the pan and tilt head and payload before pressurizing the pedestal. The Osprey Elite S pedestal has the standard four-bolt mounting plate which permits the use of various Vinten camera mounts including pan and tilt heads, Quickfix and Mitchell adapters. The mounting bolts are captive in the pedestal and the bolt heads are accessible from the underside of the mounting plate with the column fully depressed and the safety catch engaged. However, installation of the pan and tilt head is facilitated if the column is extended.



A pressurized pedestal will rise rapidly when safety catch is released. Do not lean over the pedestal when releasing the safety catch. Always restrain the pedestal by hand pressure on the steering ring when the safety catch is released.

Fit the pan and tilt head and payload as follows:

1. Ensure pedestal pressure does not exceed 3.5 bar (50 psi). Reduce as necessary, using the Schrader valve cap (25).

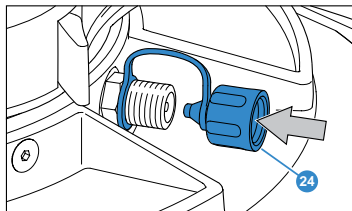

2. Push down on the steering ring (23) against residual pressure and release the safety catch (6). Allow the column to extend under hand restraint.
3. Apply the on-shot clamp (22).
4. Fit the pan and tilt head and tighten the bolts securely using a

flat-bladed screwdriver or a spanner of the correct size. A Vinten spanner, Part No. J551-001, is available for this purpose.

5. Set the safety catch slide (6) to LOCK position (I), release the on-shot clamp (22) and lower the moving column under hand restraint until the safety catch engages.

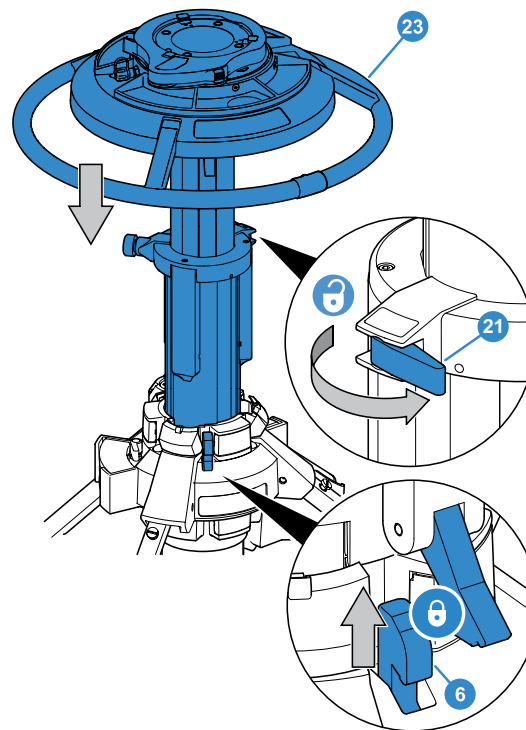

Installation

6. Fit the camera and accessories to the mounting, ensuring that all items such as pan bars, prompters, lenses etc., are fitted. Attaching these items at a later stage may upset the pedestal balance. Install three trim weights (7) on the weight tray (3).

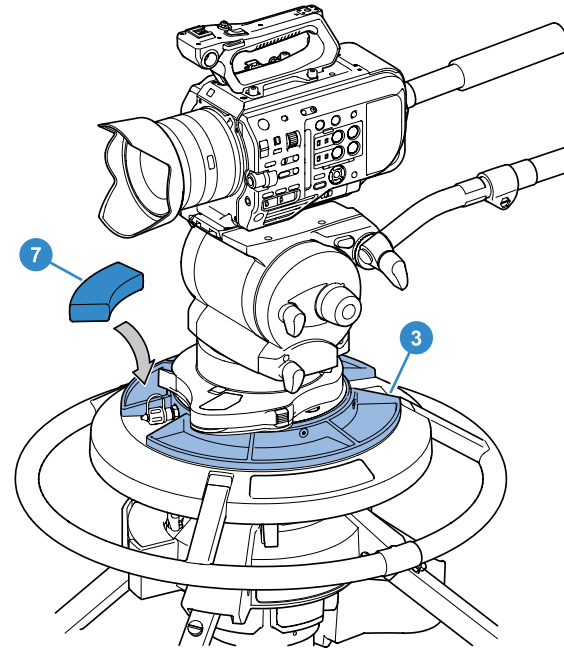
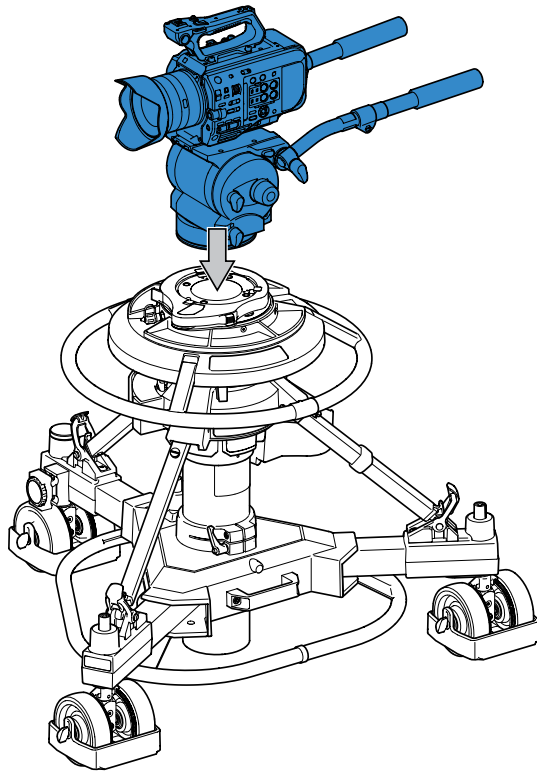

Pressurizing the pedestal

The pedestal may be pressurized by using a Portable Pump or from an external pressure source.

Ascertain the payload to be fitted to the pedestal (payload = pan and tilt head, camera, lens and all ancillary equipment). Referring to the graph below, mark the payload on the horizontal axis then strike a vertical line from the load figure to the balance line. At the intersecting point strike a horizontal line to the vertical axis and read off the required gas pressure.

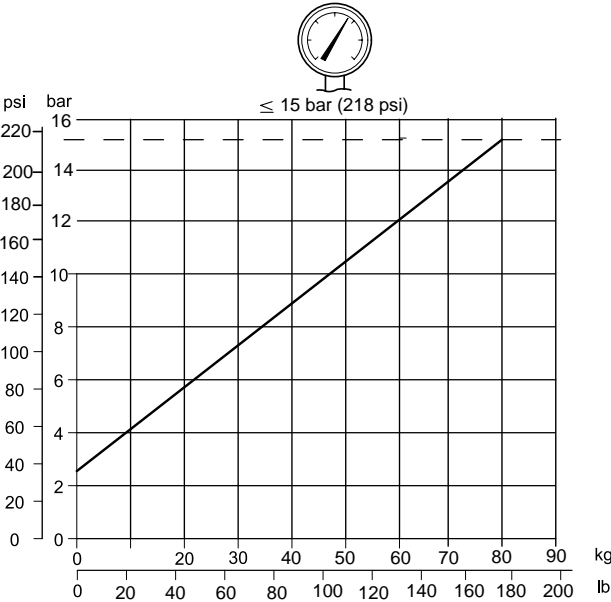

WARNING! Do not pressurize the pedestal beyond the maximum safe working pressure indicated by the leading edge of the red sector on the gauge. The pedestal is fitted with a pressure relief valve as a safeguard against over-pressurization. Do not attempt to adjust the pressure relief valve.



WARNING! This pedestal must be pressurized only with clean, dry air or nitrogen. A pressure reducing valve must be fitted to the pressure line between the gas cylinder and the outlet connection of the hose. The reducing valve must be screwed into the gas cylinder outlet. The maximum pressure on the outlet side of the reducing valve must not exceed ≤ 15 bar (218 psi). Do not pressurize the pedestal beyond the maximum safe working pressure indicated by the leading edge of the red sector on the gauge. The pedestal is fitted with a pressure relief valve as a safeguard against over-pressurization.

Do not attempt to adjust the pressure relief valve.



WARNING! A pressurized pedestal will rise rapidly when safety catch is released. Do not release safety catch when pedestal is pressurized and balancing load is not installed. Always restrain the pedestal by hand pressure on the steering ring when the safety catch is released.



WARNING! The column will rise rapidly if released with no payload fitted. Do not lean over the pedestal when releasing the safety catch.

Method	Advantages	Disadvantages
Gas Bottle	<ul style="list-style-type: none"> Fast Can add gas with payload fitted 	<ul style="list-style-type: none"> Not always available Recommended training needed for working with compressed gas.
Manual Floor Pum	<ul style="list-style-type: none"> Easy for topping up. Readily available Self pump not available for all peds. 	<ul style="list-style-type: none"> Physically demanding so not recommended for payloads over 60kg. Some pumps cannot achieve max pressure on some models.

Installation

Pressurizing the pedestal using a portable pump



WARNING! Do not pressurize the pedestal beyond the maximum safe working pressure indicated by the leading edge of the red sector on the gauge. The pedestal is fitted with a pressure relief valve as a safeguard against over-pressurization. **Do not** attempt to adjust the pressure relief valve.



WARNING! A pressurized pedestal will rise rapidly when safety catch is released. Do not release safety catch when pedestal is pressurized and balancing load is not installed. Always restrain the pedestal by hand pressure on the steering ring when the safety catch is released.

To pressurize the pedestal using the Vinten portable *pump, proceed as follows:

Attach the intended payload, ensuring that all items such as pan bars, prompters, lenses etc., are fitted.

1. Set the safety catch slide (6) to the LOCK position (1) and fully depress the moving column until the safety catch engages.
2. Unclip the hose from the pump. Turn the Steering ring (22) so the pressure gauge (2) can be seen through the weight tray.
3. Screw the valve adaptor to the pedestal charging valve (24). Ensure the pump nozzle is fitted securely onto the adaptor and is firmly locked in position.
4. Stand over the pump with both feet on the base treads.
5. Gripping the handle with both hands, and using full steady strokes, pressurize the pedestal to the required pressure. Do not exceed the maximum working pressure, indicated by the leading edge of the red sector on the gauge.

6. Disconnect the pump hose and valve adaptor from the pedestal charging valve.

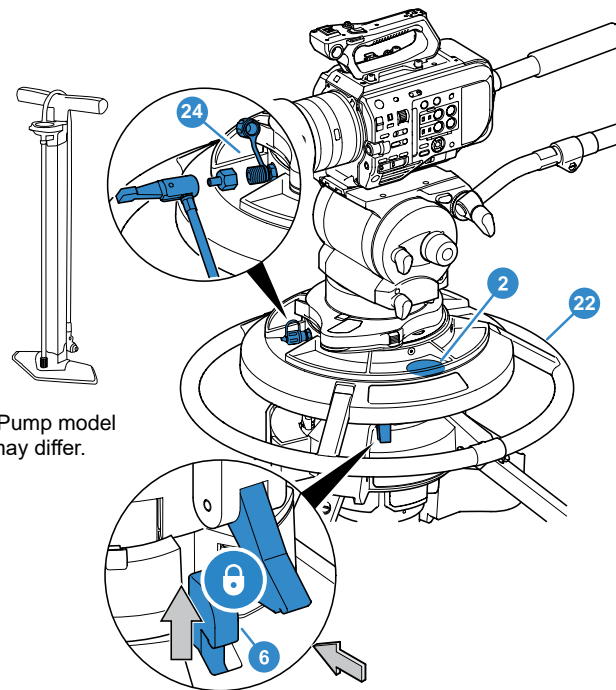

Pressurizing from an external pressure source



WARNING! This pedestal must be pressurized only with clean, dry air or nitrogen. A pressure reducing valve must be fitted to the pressure line between the gas cylinder and the outlet connection of the hose. The reducing valve must be screwed into the gas cylinder outlet. The maximum pressure on the outlet side of the reducing valve must not exceed ≤ 15 bar (218 psi).

Do not pressurize the pedestal beyond the maximum safe working pressure indicated by the leading edge of the red sector on the gauge. The pedestal is fitted with a pressure relief valve as a safeguard against over-pressurization.

Do not attempt to adjust the pressure relief valve.



WARNING! A pressurized pedestal will rise rapidly when safety catch is released. **Do not** release safety catch when pedestal is pressurized and balancing load is not installed. Always restrain the pedestal by hand pressure on the steering ring when the safety catch is released.

To pressurize the pedestal from an external pressure source, proceed as follows:

Attach the intended payload, ensuring that all items such as pan bars, prompters, lenses etc., are fitted.

1. Set the safety catch slide (6) to LOCK position (I) and fully depress the moving column (5) until the safety catch engages.
2. Turn the Steering ring (22) so the pressure gauge (2) can be seen through the weight tray.
3. Remove the Schrader valve cap (24) and connect the charging line from the pressure source.
4. Turn on the pressure supply and slowly increase the pedestal pressure to the required pressure. Do not exceed the maximum working pressure, indicated by the leading edge of the red sector on the gauge (2).
5. Disconnect the charging line, but do not refit the Schrader valve cap at this stage.

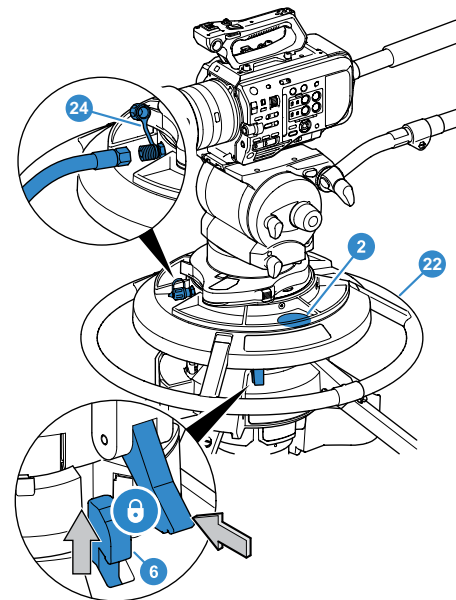

Installation

Balancing the Payload

After pressurization of the pedestal, the pan and tilt head and payload can be accurately balanced, as follows:

Push down on the steering ring (22) against residual pressure and release the safety catch (6). Allow the column to extend under hand restraint.

Exercise the moving column (5) over its full travel at least twice, then position the column in the mid-height position.

If the column tends to fall, remove a trim weight (7) or increase pressure.

If the column tends to rise, reduce the pressure in steps of 0.15-0.20 bar (2-3 psi) using the Schrader valve cap (24).

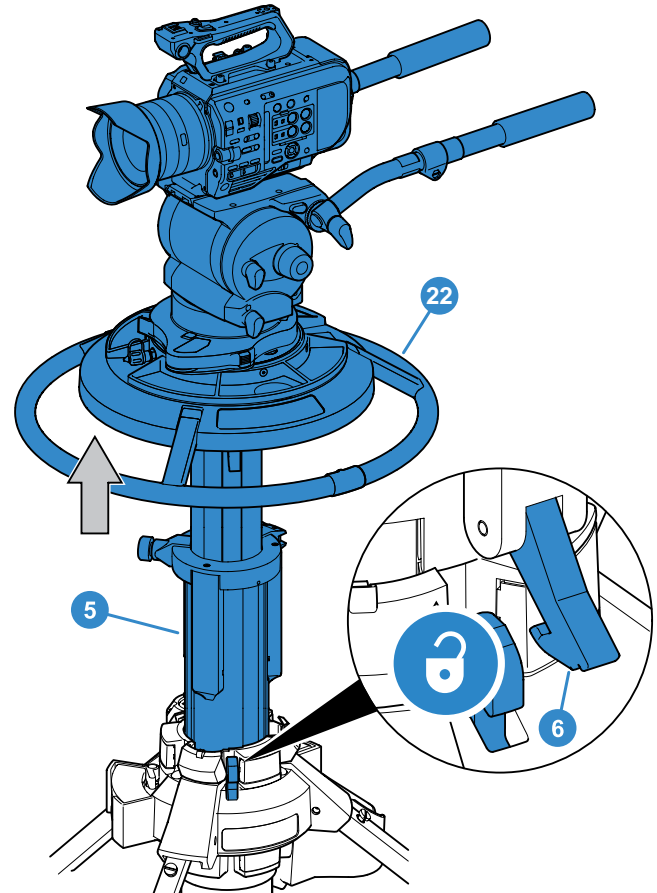



WARNING! Do not reduce pedestal pressure below 3.5 bar (50 psi). This ensures that the elevating mechanism remains in tension.



WARNING! The Schrader valve cap (3) forms a primary pressure seal. Always replace the cap and screw it down finger-tight.

A correctly pressurized pedestal will balance its payload such that it can be moved to any position over the full on-shot stroke of the moving column, with minimum effort, and it will maintain its position when the steering ring is released.

Fine balance and temperature correction may be achieved by adding or removing trim weights (7).

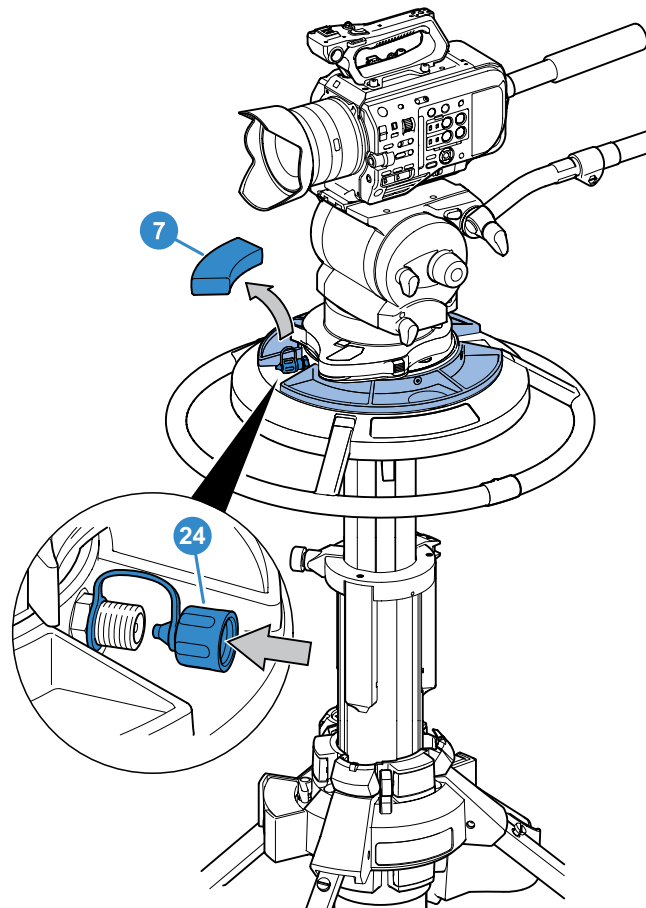

Operation

Height adjustment

The column has an on-shot stroke of 770 mm (30 in.) and the load can be moved over this distance, in perfect balance, by raising and lowering the steering ring (22). The movement is adjustable for drag (20) and an on-shot clamp (21) can be used to hold the moving column in position if fixed height operation is required.

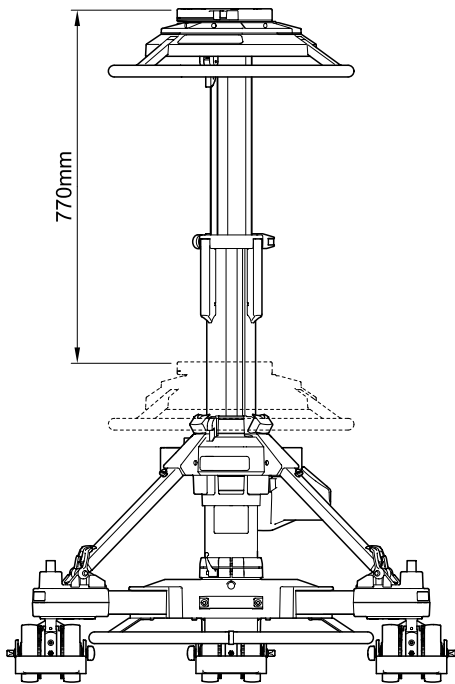

Drag control

Column movement is adjustable for drag and this is set according to operator preference by means of the drag control (20) located at the top of the outer tube. Turn the control clockwise to increase the drag setting, and counter-clockwise to decrease it.

On-shot clamp

An on-shot clamp (21) can be used to hold the moving column in position if fixed height operation is required. Move the clamp lever fully to the left to apply the clamp. Move it fully to the right to release the clamp.

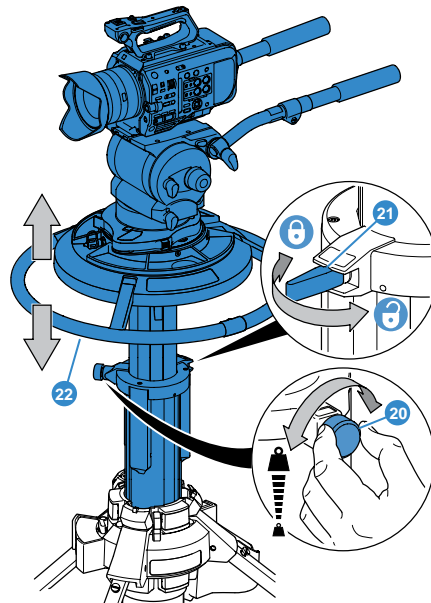

Brakes

The skid is fitted with brakes on the wheels on the folding legs. The brakes are operated by pressing on the foot-buttons (4) located above the wheels. Press once to apply the brake and again to release it.



WARNING! Always apply the brakes when the pedestal is left unattended.

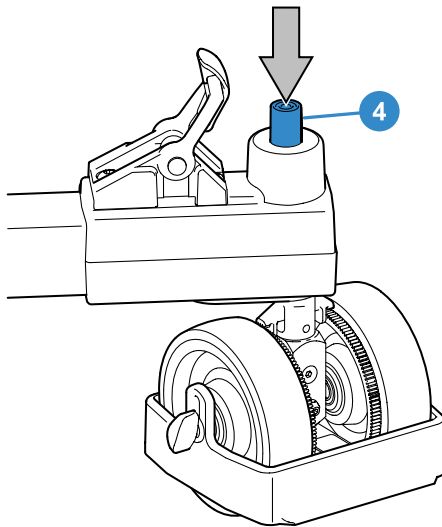

Cable guards (Studio Version)

The cable guards (17) are height-adjustable and should be set as required.

Adjustment is carried out by slackening the knobs (17.1), setting the cable guards at the required height and re-tightening the knobs.

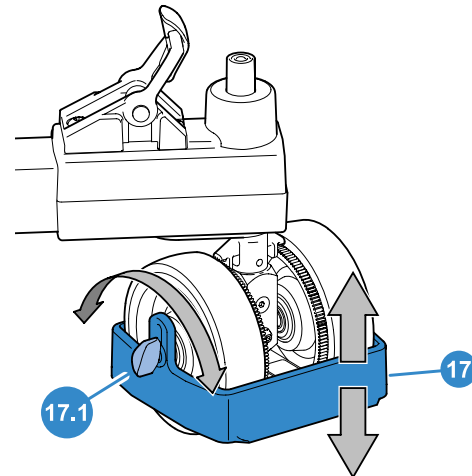

Steering

Directional control of the pedestal is achieved by turning the steering ring mounted at the top of the column. The steering system is geared so that the skid wheels turn by the same amount as the steering ring. This ensures, for example, that with the pedestal set to crab, turning the steering ring by 90° will also cause the pedestal to change direction by 90°. The steering ring is fitted with two movable indicators (4) which can be used to mark the straight-ahead position of the ring and will provide a reference point when steering.

Movable indicators

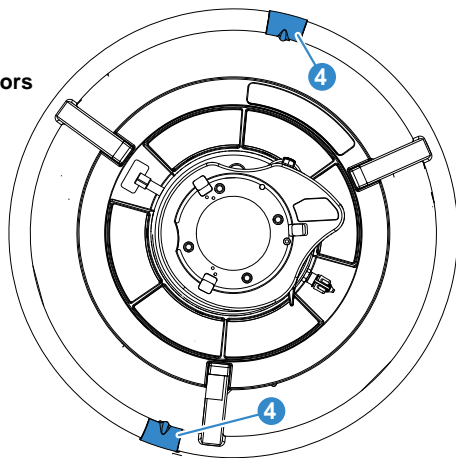

The skid has a crab/steer arrangement with a foot-operated changeover mechanism, which provides a steer setting i.e. one wheel steering, two fixed; or a crab setting, where all three wheels turn together.

Pushing the foot-button (15) operates a changeover mechanism which toggles the pedestal between crab and steer. The button can be pressed with the wheels in any position, but the changeover will not occur until the wheels are all facing forward, so the steering ring may have to be turned by up to 180° before the changeover mechanism engages. This arrangement ensures that the rear wheels will always lock in the straight-ahead position when changing from crab to steer.

A clutch in each wheel unit disconnects that wheel from the steering in the event of the wheel striking an obstacle. To reconnect the wheel, hold the steering ring stationary and turn the wheel unit until the clutch re-engages.



WARNING! To ensure maximum stability, particularly when moving over uneven ground, reduce pedestal height to a minimum.

Position 1 for one wheel steering with two fixed wheels.
Position 3 for Crab steer, all three wheels turn together.

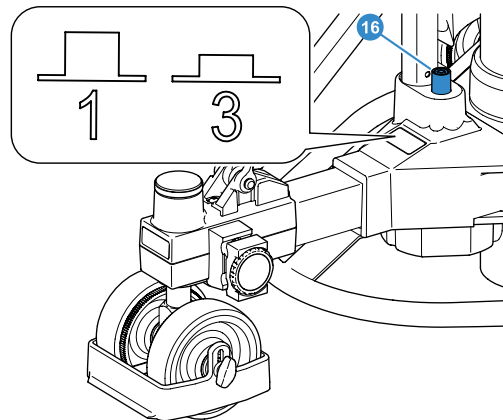

Steering Tiller

The steering tiller (Part No.3329-21) provides an alternative means of steering the skid. It is particularly useful when the skid is fitted with a head-to-skid adapter or fixed column, or when a grip is required to manoeuvre the pedestal.

The tiller is fitted as follows:

Unscrew and remove the round cap which is fitted on the tiller socket (17) on the end of the fixed skid leg. The cap may be used to close the steering tube socket if the skid is used without the column installed.

Fit the tiller bar (17.1) in the tiller socket and engage it with the drive dog.

The pedestal can now be steered by turning the tiller bar or steering ring.

Crab/steer changeover is carried out in the usual manner.

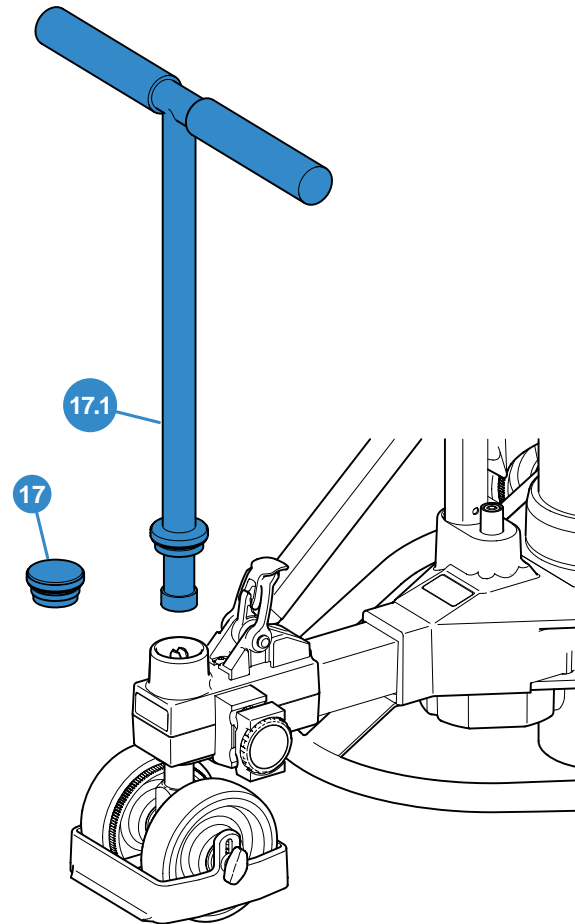

Operation

Changing the skid tracking width

The movable skid legs can be set to either of two positions.

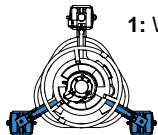

1: Wide for normal use, maximum stability.

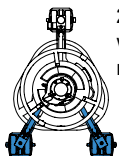

2: Narrow for a reduced width for tracking through narrow doorways etc.

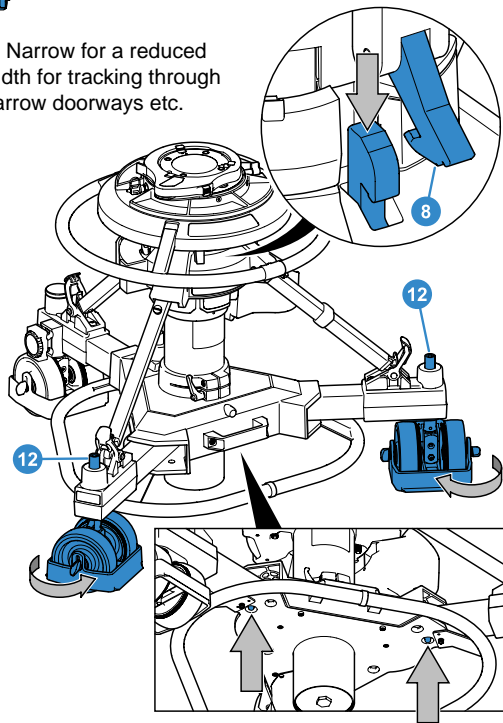

WARNING! To ensure maximum stability when the skid is set to narrow track, particularly when moving over uneven ground, reduce pedestal height to a minimum

Set the column to its lowest setting and engage the safety catch (8).

Ensure that the brakes (12) are released and then turn the skid wheels so they are pointing at right angles to the skid legs.

Reach under the pedestal, depress one of the spring-loaded locking plungers and move the leg to the required position, ensuring that the plunger has engaged correctly at the new location, repeat for the second leg.

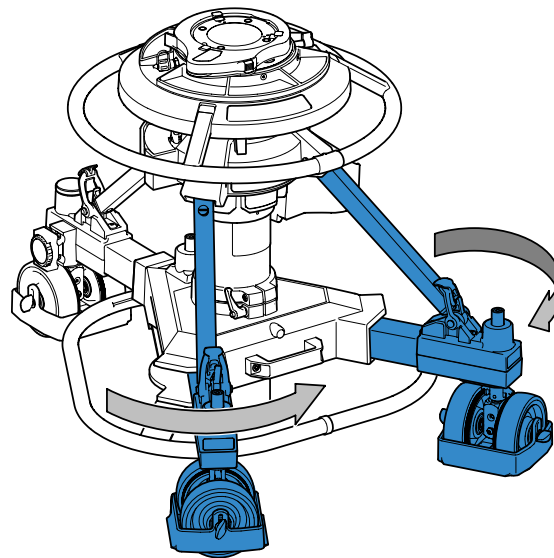

Optional wheels

A set of 160 mm (6.3 in.) wheels (Part No. 3329-30) is available to convert the skid from studio to OB use.

A set of 125 mm (5 in.) wheels with cable guards (Part No. 3329- 43) is available to convert an OB skid to a studio skid.

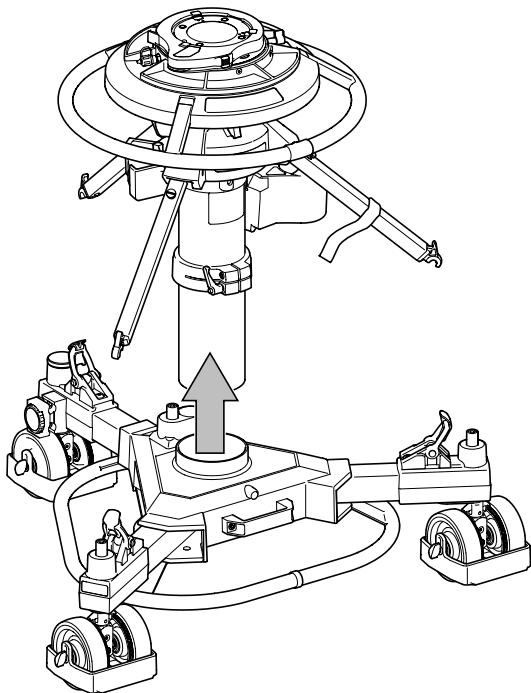

To replace the wheels:

Remove the column from the skid (see **Transportation and storage** on page 26 and turn the skid upside down.

Unscrew and remove the countersunk screw (1) securing the wheel assembly (2) to the shaft (3).

Remove the wheel assembly, complete with cable guard.

Repeat for remaining two wheel assemblies. Store the wheels for future use.

Fit the replacement wheel assemblies (4) to the shafts (3) and secure each wheel assembly to the shaft with the countersunk screws (1).

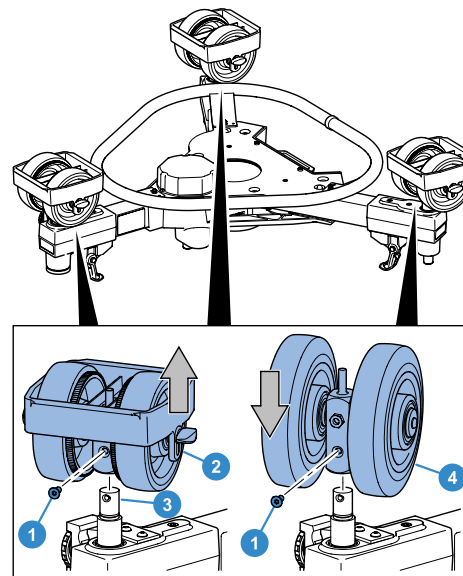

Operation



WARNING! Local, national or international regulations may apply to the transport and storage of pressurized pedestals, specifically, not to be classed as dangerous goods under IATA regulation UN 1956 - Compressed Gas Shipping. Pressure must be reduced to 2bar (28psi) or less. See Service Bulletin V4002- 4990 for further information and instruction.



WARNING: Ensure the pedestal pressure is increased to a minimum of 3.5 bar (50 psi) before attempting to raise the column. This ensures that the elevating mechanism remains in tension

WARNING! Do not reduce pedestal pressure below 3.5 bar (50 psi).



To facilitate removal of the camera and mounting, pressure should be reduced to 3.5 bar (50 psi).

Transportation and storage

The column and skid may be separated to facilitate transport or storage.

To separate the column and skid:

1. Apply the brakes (11).
2. Set the safety catch slide (6) to LOCK position (I) and fully depress both columns until the safety catch engages.
4. Remove the load and secure any trim weights in the trim weight stowage.

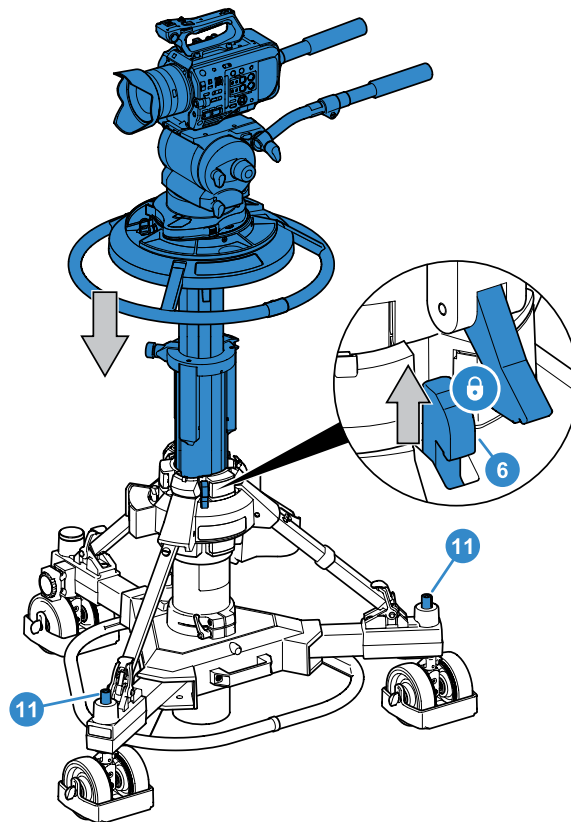

5. Release the skid clamp (9).
6. Release the three rubber foot straps (10) from the struts.
7. Raise the struts (8 / 18) then lift the complete column vertically off the skid.
8. Remove the steering ring by unscrewing each fastener until it releases. Lift the steering ring off its mounting plate.
9. Turn the skid over, remove the kick ring (2) by releasing all three locks and lifting it up. Depress the locking plungers and fold the skid legs, ensuring that the plungers lock in the closed position.

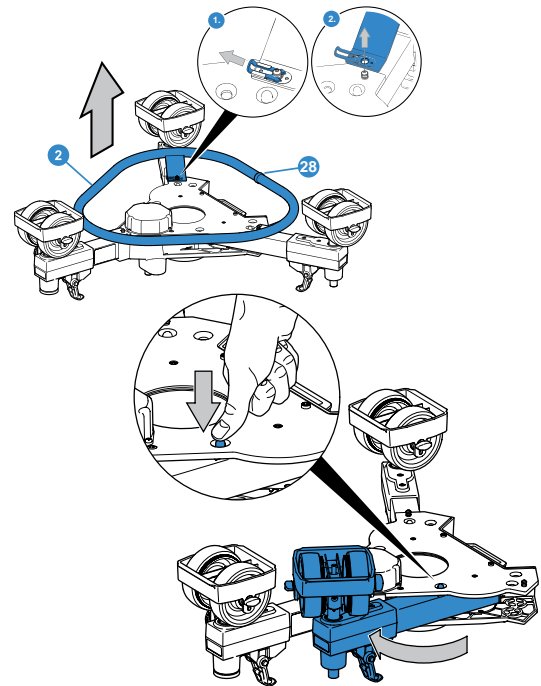
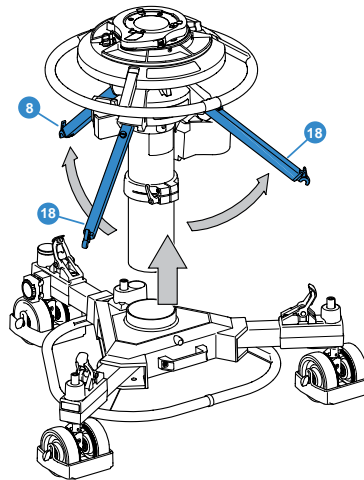
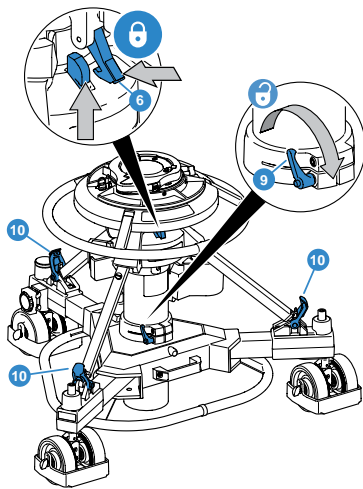

WARNING! The column will be unstable if stood on its base or on the folded struts.

Servicing

General

The Osprey pedestal is robustly made to high engineering standards and little attention is required to maintain serviceability except for regular cleaning. Attention to the following points will ensure a long and useful service life with minimum need for repair.

Cleaning

During normal studio use, the only cleaning required should be a regular wipe over with a lint free cloth. Dirt accumulated during storage or periods of disuse may be removed with a semi stiff brush. Particular attention should be paid to the flats on the top stage of the column.



CAUTION! Do NOT use oil or grease on any exposed part of the column. This is unnecessary and traps dirt which acts as an abrasive.

Use out-of-doors will require special attention, especially in adverse conditions. Salt spray must be washed off with fresh water at the earliest opportunity. Do not allow water to enter the column.

Sand and dirt acts as an abrasive and should be removed with a semi-stiff brush or vacuum cleaner.



NOTE: Use only detergent-based cleaners. Do NOT use solvent- or oil-based cleaners, abrasives or wire brushes to remove accumulations of dirt, as these damage the protective surfaces.

Routine Checks

The Osprey requires minimal routine maintenance, apart from checking the connections and overall operation periodically.

Check the following points during normal use:

- Check for ageing and cracking of the rubber securing straps and renew if necessary.
- Check the effectiveness of the clamps.
- Check for radial or side play in the moving column.

Adjustments

Adjustments which may become necessary after considerable use are as follows:

- Taking up wear in the skid clamp.
- Elimination of radial and side play on the moving column.

Skid clamp adjustment

The skid clamp is applied and released by turning the handle clockwise or counter-clockwise. The handle has a push-on/pull-off type ratchet adjustment.

To adjust the skid clamp pull the clamp handle away from the spindle, rotate it counter clockwise and release.

Repeat the above procedure, as necessary, until the clamp locks when applied but allows free movement when released.

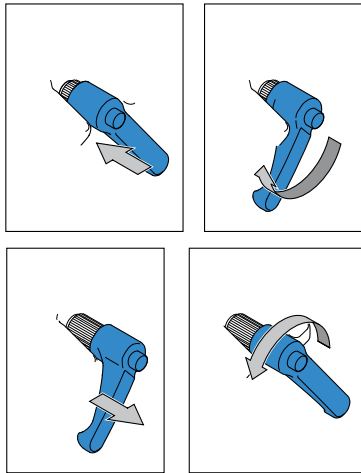

Elimination of radial and side play on the elevation tube or top stage

If excessive radial or side play is apparent on the elevation tube or top stage. Then this adjustment should be carried out by a competent and suitably trained person.

Routine maintenance

At three-yearly intervals, the three steel wire ropes in the column elevation mechanism should be replaced.

This procedure should be carried out by a competent trained person.

Technical Specification

Physical Data (Studio V4171-0001)



Minimum height
660 mm (26. in.)



Tracking Width
970 mm (38.2 in.)



Maximum height
1430 mm (56 in.)



Doorway Tracking Width
730 mm (28.7 in.)



Maximum payload
80 kg (176 lb)



Stages
2



Weight
46.6kg (102.8 lb)



Max working pressure
≤ 15 bar (218 psi)



Steering Ring Diameter
533 mm (21 in.)



Relief valve pressure
16.5 bar (240 psi)



On-shot stroke
770mm (30.3 in.)



Ground clearance
20 mm (0.8 in.)



Transit Width
800 mm (31.5 in.)

Physical Data (OB V4171-0002)



Minimum height
685 mm (27 in.)



Tracking Width
940 mm (37 in.)



Maximum height
1455 mm (57.2 in.)



Doorway Tracking Width
700 mm (27.6 in.)



Maximum payload
80 kg (176lb)



Stages
2



Weight
50.5 kg (100.9 lb)



Max working pressure
≤ 15 bar (218 psi)



Steering Ring Diameter
533 mm (21 in.)



Relief valve pressure
16.5 bar (240 psi)



On-shot stroke
770 mm (30.3 in.)



Ground clearance
34.5 mm (1.4 in.)



Transit Width
800 mm (31.5 in.)

Environmental Data



Operating temperature range
+5°C to +40°C (41°F to +104°F)



Storage temperature range
-20°C to +60°C (-4°F to +140°F)

Technical specifications are subject to change without notice.



EU Declaration of Conformity

Videndum Production Solutions Ltd. declares under our sole responsibility, supported by Videndum Production Solutions GmbH - our authorized representative, that the product detailed in this manual conforms with all relevant provisions of the following EU directives:

Machinery Directive 2006/42/EC

A copy of the declaration is available on request.



UK Declaration of Conformity

Videndum Production Solutions Ltd. declares under our sole responsibility that the product detailed in this manual conforms with all relevant provisions of the following UK Regulations:

The Supply of Machinery (Safety) Regulations 2008

A copy of the declaration is available on request.

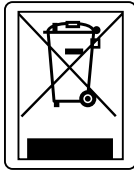

Environmental considerations

European Union Waste of Electrical and Electronic Equipment (WEEE) Directive (2002/96/EC)

This symbol marked on the product or its packaging indicates that this product must not be disposed of with general household waste. In some countries or European Community regions separate collection systems have been set up to handle the recycling of electrical and electronic waste products. By ensuring this product is disposed of correctly, you will help prevent potentially negative consequences for the environment and human health. The recycling of materials helps conserve natural resources.

Visit our website for information on how to safely dispose of this product and its packaging.

In countries outside the EU:

Dispose of this product at a collection point for the recycling of electrical and electronic equipment according to your local government regulations.

Pollution statement

This equipment is designed for operation in Pollution Degree 2 environments.

Vinten



Vinten
A Videndum plc Brand

www.videndum.com